

COMPACT GEARS



Edition 2024

HYDRO · MEC
HIGH EFFICIENCY GEARBOXES

Aluminum & cast iron shaft mounted gearboxes

A modular and compact product

Gears
Hardened and ground gears

Alloy housing
Is vacuum impregnated (MIL-STD 276) for protection and sealing. No secondary finish required but readily accepts paint or cast iron for larger units.

Flange
Fully modular to IEC and Compact integrated motor.
NEMA C flange

Large center distance

Removable inspection cover
Allows periodic inspection of gearing during routine maintenance

Large center distance
On slow gears for safe torque transmission.

Single-piece aluminum / Cast Iron housing

Combines light weight with high tensile strength. Precision machined for alignment of bearings and gearing

Painting

Cast iron gearboxes are painted RAL 7046



World wide sales network.

Specific type datasheet on page...

On page / A pagina / Auf Seite / À la page / En la página

3 Stage

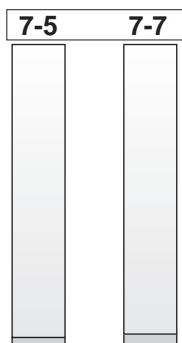

Types / Tipi /
Tipen / Types /
Tipos →

FS10 60Nm
FS20 90Nm

On page / A pagina / Auf Seite / À la page / En la página

1 Stage

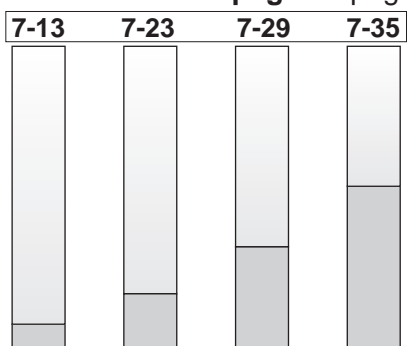
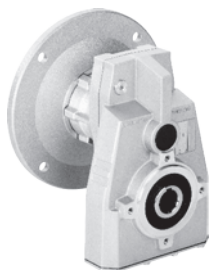

Types / Tipi /
Tipen / Types /
Tipos →

FA41 225Nm
FC61 380Nm
FC71 670Nm
FC81 1175Nm

On page / A pagina / Auf Seite / À la page / En la página

2 and 3 Stage

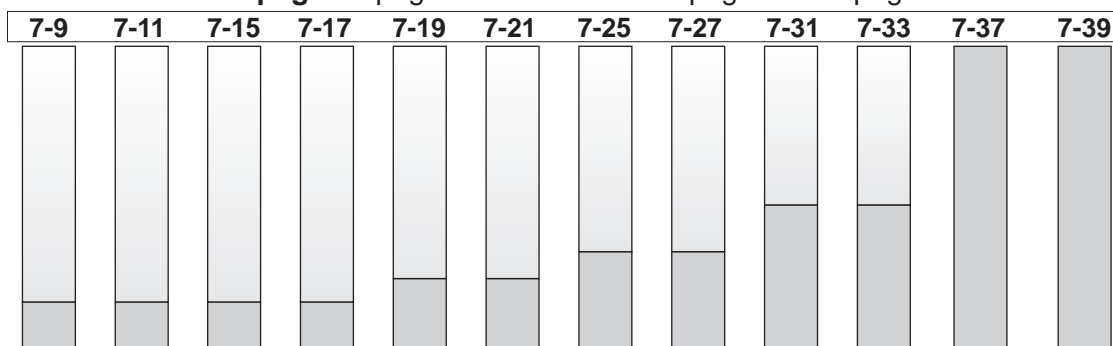

Types / Tipi /
Tipen / Types /
Tipos →



FA32 150Nm
FA33 150Nm
FA42 320Nm
FA43 320Nm
FA52 490Nm
FA53 510Nm
FC62 675Nm
FC63 675Nm
FC72 900Nm
FC73 900Nm
FC82 2100Nm
FC83 2100Nm

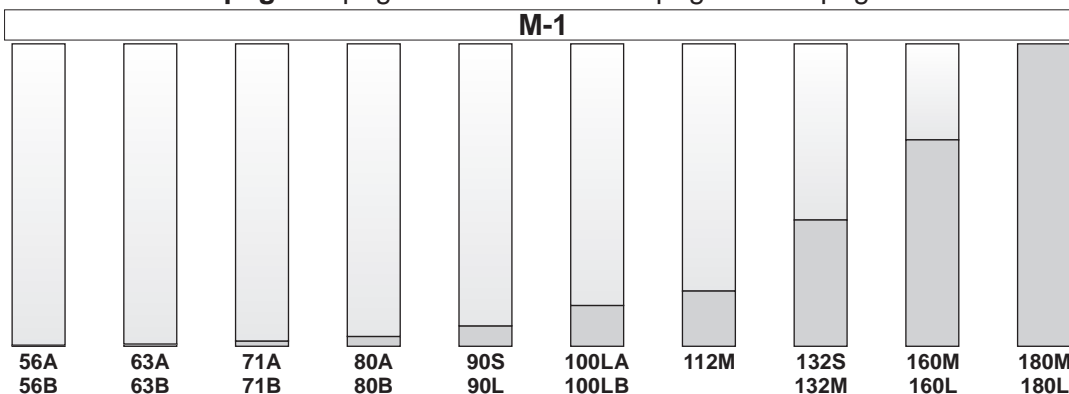





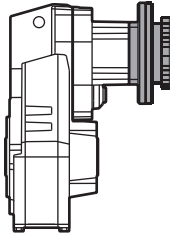
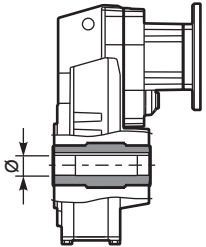
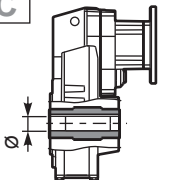
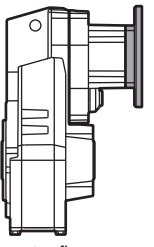
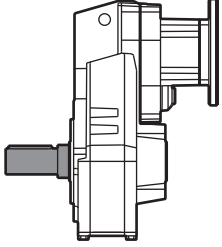
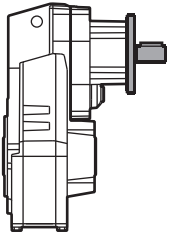
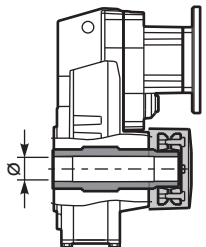
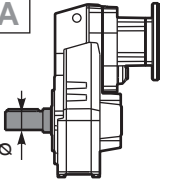
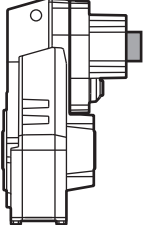
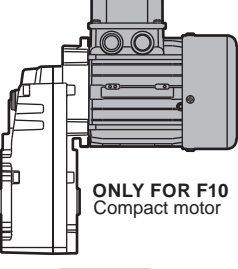

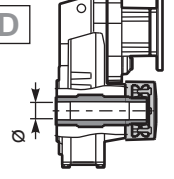

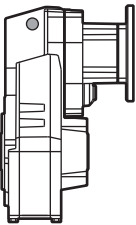
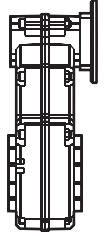
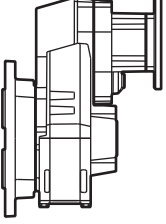
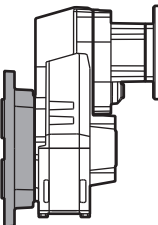
On page / A pagina / Auf Seite / À la page / En la página

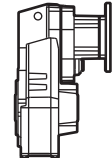
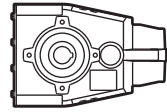
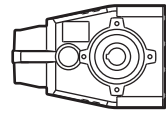
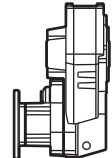
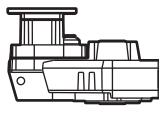
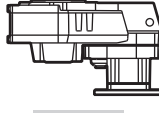
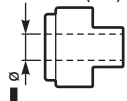

Types / Tipi /
Tipen / Types /
Tipos

56A 56B
63A 63B
71A 71B
80A 80B
90S 90L
100LA 100LB
112M
132S 132M
160M 160L
180M 180L

Type - Tipo - Typ Type - Tipo	Size - Grandezza - Größe Taille - Tamaño	Mounting - Montaggio Montage - Fixation Tipo de montaje	Rapporto - Ratio Untersetzung Reduction - Relacion	Output shaft Albero uscita Abtriebswelle Arbre de sortie Eje en salida
M	FA42	C	10.04	-D
<p>Shaft mounted helical Riduttori ad assi paralleli</p>  <p>With IEC motor</p> <p>M</p>	<p>1 Stage Riduzione Stufe Trains Etapas</p> <p>2 Stages Riduzioni Stufen Trains Etapas</p> <p>3 Stages Riduzioni Stufen Trains Etapas</p> <p>Aluminum/Alluminio/Aluminium/Aluminio</p> <p>FA41</p> <p>FA32 FA42 FA52</p> <p>FA33 FA43 FA53</p> <p>FS10 FS20</p>	 <p>Hollow output shaft</p> <p>C</p>	<p>See technical data table</p> <p>Vedi tabelle dati tecnici.</p> <p>Technisches Datenblatt beachten</p> <p>Voir Tableau données techniques</p> <p>Ver tabla datos técnicos</p>	<p>C</p>  <p>STANDARD Only on request for Q.ty A richiesta per quantità</p>
 <p>With motor flange</p> <p>P</p>	<p>Cast Iron/Ghisa/Grauguss/Fonte/Fundicion</p> <p>FC61 FC71 FC81</p> <p>FC62 FC72 FC82</p> <p>FC63 FC73 FC83</p>	 <p>Single output shaft</p> <p>A</p>		<p>FS10</p> <p>-J → ∅17</p> <p>FS20</p> <p>-B → ∅20</p> <p>FA32-3</p> <p>-C → ∅25</p> <p>FA41 FA42 FA43</p> <p>-C ⇔ ∅25</p> <p>-D → ∅30</p> <p>-E ⇔ ∅35</p> <p>FA52 FA53 FC61 FC62 FC63</p> <p>-E → ∅35</p> <p>-F ⇔ ∅40</p> <p>FC71 FC72 FC73</p> <p>-F → ∅40</p> <p>-G ⇔ ∅45</p> <p>FC81 FC82 FC83</p> <p>-H → ∅50</p> <p>-I ⇔ ∅55</p>
<p>7</p>  <p>With male input shaft</p> <p>R</p>	<p>FC61 FC71 FC81</p> <p>FC62 FC72 FC82</p> <p>FC63 FC73 FC83</p>	 <p>Shrink Disk</p> <p>D</p> <p>Only on request for Q.ty A richiesta per quantità</p>		<p>A</p>  <p>Single output shaft</p> <p>-L FA32/3 ⇔ ∅25</p> <p>-M FA41/2/3 ⇔ ∅30</p> <p>-N FA52/3 FC61/2/3 ⇔ ∅35</p> <p>-O FC71/2/3 ⇔ ∅40</p> <p>-K FC81/2/3 ⇔ ∅50</p>
 <p>Modular base</p> <p>B</p> <p>Not available for: FC61, FC71, FC81, FC82.</p>	<p>FC61 FC71 FC81</p> <p>FC62 FC72 FC82</p> <p>FC63 FC73 FC83</p>			
 <p>ONLY FOR F10 Compact motor</p> <p>C</p>	<p>On request we can deliver our products according to the ATEX A richiesta possiamo fornire i nostri prodotti secondo le normative ATEX Auf Anfrage können wir unsere Produkte den Richtlinien ATEX entsprechend liefern Sur demande nos produits peuvent se conformer à la réglementation ATEX A pedido, se pueden enviar nuestros productos de acuerdo con las normas ATEX.</p> 			<p>D</p>  <p>Shrink disk</p> <p>-Q FA42/3 ⇔ ∅30</p> <p>-T FA52/3 FC62/3 ⇔ ∅35</p> <p>-U FC72/3 ⇔ ∅40</p> <p>-V FC82/3 ⇔ ∅50</p>

Type - Tipo - Typ Types - Tipo	Output flange Flangia uscita Ausgangsflansch Bride de sortie Brida en salida	Motor size - Grandezza motore Motor Grösse Grandeur moteur - Tamaño motor	Mounting position Posizione montaggio Einbaulage Position de montage Position de montage	Input bore Foro entrata Eingangshohlwelle Trou d'entree Eje hueco de entrada	Terminal box position Posizione morsettiere Klemmkastenlage Position boîte à bornes Posición caja de bornes
<p>ST</p>  <p>ST Foro standard Standard bore</p>  <p>ST Senza braccio di reazione Without reaction arm</p>  <p>-F Whit output flange con flangia uscita</p>	<p>N</p>  <p>N Senza flangia Without flange</p> <p>FS20</p> <p>1 → ∅140</p> <p>FA32-3 FA41-2-3</p> <p>2 → ∅160</p> <p>3 → ∅200</p> <p>4 → ∅250</p> <p>FA52 FA53 FC61 FC62 FC63</p> <p>4 → ∅250</p> <p>FC71 FC72 FC73</p> <p>4 → ∅250</p> <p>5 → ∅300</p> <p>FC81 FC82 FC83</p> <p>5 → ∅300</p> <p>6 → ∅350</p>	<p>-C</p>  <p>Flange Flangia</p> <p>B5</p> <p>-A=56 (∅120)</p> <p>-B=63 (∅140)</p> <p>-C=71 (∅160)</p> <p>-D=80 (∅200)</p> <p>-E=90 (∅200)</p> <p>-F=100 (∅250)</p> <p>-G=132 (∅300)</p> <p>-H=160 (∅350)</p> <p>-I=180 (∅350)</p> <p>B14</p> <p>-O=56 (∅80)</p> <p>-P=63 (∅90)</p> <p>-Q=71 (∅105)</p> <p>-R=80 (∅120)</p> <p>-T=90 (∅140)</p> <p>-U=100 (∅160)</p> <p>-V=132 (∅200)</p> <p>Brushless</p> <p>BB=50/70-M5</p> <p>BC=60/75-M5</p> <p>BD=70/90-M6</p> <p>BE=80/100-M6</p> <p>BF=95/115-M8</p> <p>BG=110/145-M8</p> <p>BH=130/165-M8</p> <p>Type R Tipo R</p>  <p>FA33 FA43 FS10 FS20</p> <p>-1 → ∅14</p> <p>FA32 FA42 FA53 FC63 FC73</p> <p>-2 → ∅19</p> <p>FA52 FC62 FC72 FC83</p> <p>-3 → ∅24</p> <p>FC82</p> <p>-4 → ∅28</p> <p>Without flange Senza flangia</p>  <p>-M → With coupling</p> <p>FA33 FA43 FS10 FS20</p> <p>-Z → ∅9 (56B5)</p> <p>-0 → ∅11 (63B5)</p> <p>-1 → ∅14 (71B5)</p> <p>FA32 FA42 FA53 FC63 FC73</p> <p>-1 → ∅14 (71B5)</p> <p>-2 → ∅19 (80B5)</p> <p>-3 → ∅24 (90B5)</p> <p>FA52 FC62 FC72 FC83</p> <p>-2 → ∅19 (80B5)</p> <p>-3 → ∅24 (90B5)</p> <p>-4 → ∅28 (100B5)</p> <p>FA41</p> <p>-4 → ∅28 (100B5)</p>	<p>H1</p>  <p>H1 STANDARD</p>  <p>H4</p>  <p>H3</p>  <p>H2</p>  <p>H5</p>  <p>H6</p>	<p>ST standard bore foro standard</p> <p>COUPLING STANDARD (IEC)</p>  <p>-A = 9mm</p> <p>-B = 11mm</p> <p>-C = 14mm</p> <p>-D = 19mm</p> <p>-E = 24mm</p> <p>-F = 28mm</p> <p>BRUSHLESS *</p>  <p>-2 = 11mm</p> <p>-3 = 14mm</p> <p>-4 = 19mm</p> <p>-5 = 22mm</p> <p>-6 = 24mm</p> <p>-0 Ready for input coupling Predisposto per giunto</p>  <p>* With reduction bushing where applicable Con bussola di riduzione dove prevista</p>	<p>With Type M specify terminal box position Con tipo M specificare posizione morsettiere</p>  <p>A</p>  <p>B STANDARD</p>  <p>C</p>  <p>D</p>

POTENZA RICHIESTA / REQUIRED POWER / ERFORDERLICHE LEISTUNG / PUISSANCE NECESSAIRE / POTENCIA NECESARIA

Lifting / sollevamento / hubantriebe / levage / elevación

$$P [KW] = \frac{M [Kg] \cdot g [9.81] \cdot v [m / s]}{1000}$$

Rotation / rotazione / drehung / rotation / rotacion

$$P [KW] = \frac{M [Nm] \cdot n [rpm]}{9550}$$

Linear movement / traslazione / linearbewegung / translation / translacion

$$P [KW] = \frac{F [N] \cdot v [m / s]}{1000}$$

TORQUE / COPPIA / DREHMOMENT / COUPLE / PAR

$$M [Nm] = \frac{9550 \cdot P [KW]}{n [rpm]}$$

$$M [lb in] = \frac{63030 \cdot P [HP]}{n [rpm]}$$

RADIAL LOADS / CARICHI RADIALI / RADIALE - UND AXIALLASTEN / CHARGES RADIALES / CARGA RADIAL Y AXIAL

- Radial load generated by external transmissions keyed onto input and/or output shafts.
- Forza radiale generata da organi di trasmissione calettati sugli alberi di ingresso e/o uscita.
- Belastungen der Antriebs- bzw. Abtriebswellen durch von aussen eingebrachte Radiallasten.
- Charge radiale générée par la transmissions calés sur les entrées et / ou des arbres de sortie
- Cargas radiales, generada por transmisiones externas, aplicadas sobre los ejes de entrada y/o salida

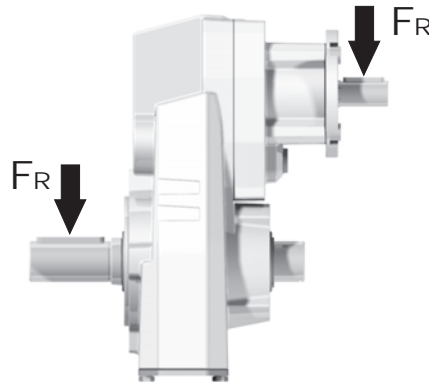

$$F_R [N] = \frac{M [Nm] \cdot 2000}{d [mm]} \cdot f_k$$

$$F_R [N] = \frac{M [lb in] \cdot 8.9}{d [in]} \cdot f_k$$

M	Momento torcente / Output torque / Abtriebsdrehmoment / Couple / Par torsion
d	Diametro primitivo / Diam. of driving element / Durchmesser der Abtriebseinheit / Diamètre primitif / Diámetro primitivo
f_k	Coefficiente di trasformazione / Factor / Faktor / Coefficient de transmission / Coeficiente de transmisión 1.15 Ingranaggi / Gearwheels / Zahnrad / Engrenage / Engranaje 1.25 Catena / Chain sprockets / Antriebskette / Chaîne / Cadena 1.75 Cinghia Trapezoidale / Narrow v-belt pulley / Keilriemen / Courroie trap. / Correa trapezoidal 2.50 Cinghia piatta / Flat-belt pulley / Flachzahnriem. / Courroie crantée / Correa plana

- If your application requires higher radial loads, contact our technical office. Higher load may be possible.
- Nel caso la vostra applicazione richieda carichi radiali superiori consultare il nostro ufficio tecnico, valori maggiori possono essere accettati.
- Wenn Ihre Anwendung höhere Radialbelastungen erfordert, so wenden Sie sich bitte an unser technischen Büro.
- Si votre application demande des charges radiales supérieures, s'adresser à notre bureau technique.
- En el caso en que una aplicación exija una carga radial superior a la especificada en el catálogo, consultar a nuestra oficinas técnica.

How to select a gearbox / Come selezionare un riduttore / Wie wählt man ein Getriebe
Comment sélectionner un réducteur / Cómo seleccionar un reductor

B Output speed
Velocità in uscita
Abtriebsdrehzahl
Vitesse de sortie
Velocidad de salida

Nominal power
Potenza nominale
Max. mögliche Leistung
Puissance nominale
Potencia nominal

A Nominal torque
Momento torcente nominale
Nenn Drehmoment
Couple nominal
Par de torsión nominal

Flange code
Codice flangia
Flanschttype
Code bride
Código bridas

Input speed
Velocità in entrata
Eintriebsdrehzahl
Vitesse en entrée
Velocidad de entrada

Gear size
Grandezza riduttore
Getriebegröße
Taille réducteur
Tamaño reductor

Motor power
Potenza motore
Motorleistung
Puissance moteur
Potencia motor

FA42

Compact-Gear 320Nm

Rating - Aluminum
SHAFT MOUNTED HELICAL

QUICK SELECTION / Selezione veloce										input speed (n ₁) = 1400 min ⁻¹								
Output Speed n ₂ [min ⁻¹]	Ratio i	Motor power P _{1M} [kW]	Output torque M _{2M} [Nm]	Service factor f.s.	Nominal power P _{1R} [kW]	Nominal torque M _{2R} [Nm]	Available B5 motor flanges					Available B14 motor flanges				Output Shaft		Ratios code
							-B	-C	-D	-E	-F	-Q	-R	-T	-U			
167	8.38	4	215	1.0	4.1	225	B					C	C			2821		01
139	10.04	3	194	1.2	3.7	240	B					C	C			2818		02
114	12.33	3	238	1.1	3.2	260	B					C	C			2813		03
92	15.16	2.2	216	1.2	2.6	260	B					C	C			1921		04

C Ratio
Rapporto
Untersetzung
Rapport de réduction
Relación

Transmitted torque
Momento torcente trasmesso
Mögliche Drehmomente
Couple de sortie
Par transmitido

Service factor
Fattore di servizio
Betriebsfaktor
Facteur de service
Factor de servicio

Output shaft diam.
Diam. albero uscita
Durchmesser abtriebswelle
Diametre arbre lent
Diametro eje de salida

Notes
Note
Anmerkungen
Note
Notas

		fs		
		3 h	10 h	24 h
Type of load and starts per hour Tipo di carico e avviamenti per ora		Oper. hours per day Ore di funz. giorn.		
Continuous or intermittent appl. with start / hour Applicazione cont. o interm. con n.ro operazioni/ora	Uniform / Uniforme	0.8	1	1.25
	Moderate / Moderato	1	1.25	1.5
	Heavy / Forte	1.25	1.5	1.75
Intermittent application with start / hour Applicazione intermittente con n.ro operazioni/ora	Uniform / Uniforme	1	1.25	1.5
	Moderate / Moderato	1.25	1.5	1.75
	Heavy / Forte	1.5	1.75	2.15

D	Motor flange available Flange disponibili Erhältliche Motorflansche Brides disponibles Bridas disponibles
B)	Mounting with reduction ring Montaggio con boccola di riduzione Reduzierhülsen Montage avec douille de réduction Montaje con casquillo de reducción
C)	Motor flangeholes position/terminal box position Posizione fori flangia/basetta motore Bohrungsposition am Motorflansch/-socket Position trous bride/barrette à bornes moteur Posición agujeros brida / base motor
B)	Available without reduction bushes Disponibile anche senza boccola Auch ohne Reduzierbuchse verfügbar Disponible aussi sans douille de réduction Disponible también sin casquillo

A	Select required torque (according to service factor)	Seleziona la coppia desiderata (comprensiva del fattore di servizio)	Max. Drehmoment in Bezug zum Betriebsfaktor	Sélectionner le couple souhaité (comprenant le facteur de service)	Seleccionar el par deseado (incluyendo el factor de servicio)
B	Select output speed	Seleziona la velocità in uscita	Ausgewählte Abtriebsdrehzahl	Sélectionner la vitesse de sortie	Seleccionar la velocidad de salida
C	On the same line of selected geared motor, you can find the gear ratio	Sulla riga corrispondente alla motorizzazione prescelta si può rilevare il rapporto di riduzione	Auf der gleichen Linie wie die ausgewählte Motorleistung steht auch die Getriebeuntersetzung	Sur la ligne correspondante à la motorisation pré-choisie on peut relever le rapport de réduction	En la línea correspondiente al motor preseleccionado es posible encontrar la relación de reducción
D	Select motor flange available (if requested)	Scegli la flangia disponibile (se richiesta)	Erhältliche Motorflansche (auf Anfrage)	Choisir la bride disponible (si elle est demandée)	Seleccionar la brida disponible (sobre pedido)



QUICK SELECTION / Selezione veloce

input speed (n_1) = 1400 min⁻¹

Output Speed n_2 [min ⁻¹]	Ratio i	Motor power P_{1M} [kW]	Output torque M_{2M} [Nm]	Service factor f.s.	Nominal power P_{1R} [kW]	Nominal torque M_{2R} [Nm]	Available B5 motor flanges		Available B14 motor flanges			Hollow Shaft standard ø17	Ratios code
							-B	-C	-O	-P	-Q		
							63	71	56	63	71		
72	19.42	0.37	46	1.3	0.48	60			C	C		281713	01
51	27.21	0.37	65	0.9	0.34	60			C	C		281313	02
36.4	38.49	0.25	62	1.0	0.24	60			C	C		191713	03
31.7	44.12	0.18	54	1.1	0.21	60			C	C		171713	04
26.7	52.50	0.18	64	0.9	0.18	60			C	C		151713	05
22.6	61.82	0.12	49	1.2	0.15	60			C	C		171313	06
19.0	73.56	0.12	58	1.0	0.13	60			C	C		151313	07
15.9	88.13	0.09	56	1.1	0.11	60			C	C		101713	08
12.0	116.67	0.06	48	1.2	0.08	60			C	C		91713	09
11.3	123.48	0.06	51	1.2	0.08	60			C	C		101313	10
9.0	155.37	0.06	64	0.9	0.06	60			C	C		71713	11
8.6	163.47	0.06	68	0.9	0.06	60			C	C		91313	12
7.6	184.39	0.06	76	0.8	0.05	60			C	C		61713	13
6.4	217.68	0.06*	90	0.7	0.04	60			C	C		71313	14
5.4	258.34	0.06*	107	0.6	0.04	60			C	C		61313	15

The dynamic efficiency is **0.94** for all ratios * Power higher than the maximum one which can be supported by the gearbox. Select according to the torque M_{2R}
Potenza superiore a quella massima sopportabile dal riduttore. Selezionare in base al momento torcente M_{2R}

- Motor Flanges Available** Flange Motore Disponibili
- B) Supplied with Reduction Bushing** Fornito con Bussola di Riduzione
- B) Available on Request without reduction bushing** Disponibile a Richiesta senza Bussola di Riduzione
- C) Motor Flange Holes Position** Posizione Fori Flangia Motore

EN Unit **FS10** is supplied with synthetic oil for lifetime lubrication, no maintenance is necessary. See table 1 for lubrication and recommended quantity. In table 2 please see possible radial loads and axial loads on the gearbox.

I Il riduttore **FS10** viene fornito completo di olio sintetico per la lubrificazione permanente e non necessita di alcuna manutenzione. Vedi tab.1 per oli e quantità consigliati. In tab.2 sono presenti i carichi radiali e assiali applicabili al riduttore.

D Das Getriebe **FS10** ist mit synthetischem Öl gefüllt und ist lebensdauergeschmiert. In Tabelle 1 ist die Schmiermenge und das empfohlene Schmiermittel angegeben. In Tabelle 2 sind die zulässigen Radial - und Axialbelastungen des Getriebes aufgeführt.

F Le réducteur **FS10** est fourni complet avec de l'huile synthétique pour la lubrification permanente et ne nécessite aucun entretien. Voir tableau 1 concernant les huiles et les quantités conseillées. Les charges radiales et axiales applicables au réducteur sont précisées dans le tableau 2.

E El reductor tamaño **FS10** se suministra, lubricado de por vida con aceite sintético y no requieren mantenimiento alguna. Ver tabla 1, para cantidades y aceites recomendados. En la tabla 2, se encuentran las cargas radiales y axiales admitidas por el reductor.

LUBRICATION FS10 Oil Quantity 0.35 Lt.

SHELL Omala S4 WE 320 **ENI** Telium VSF 320

For all details on lubrication and plugs check our website **tab. 1**
Per maggiori dettagli su lubrificazione e tappi olio vedi il nostro sito web

RADIAL LOADS

Input shaft
Albero in entrata

n_1	FA	FR
1400	140	700
900	160	800

*Strong axial loads in the DX direction are not allowed.
Non sono consentiti forti carichi assiali con direzione DX

tab. 2

PFS10... Basic gearbox
Riduttore base

Gearbox weight **3.1 kg**
peso riduttore

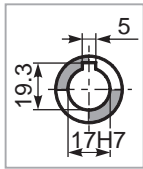

Standard
Hollow shaft

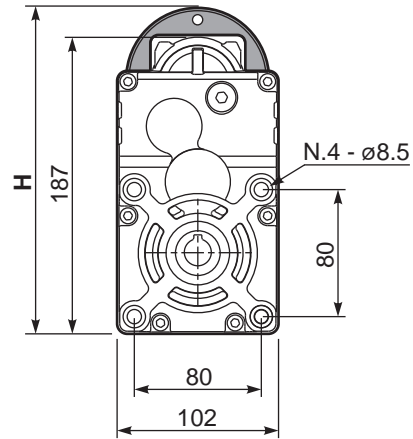
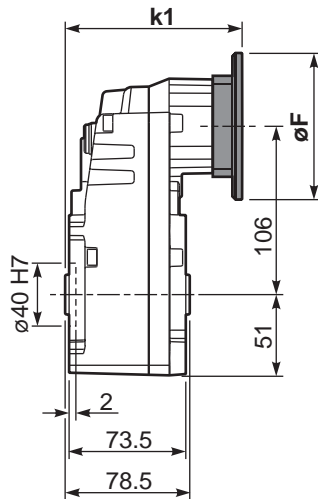

B14 Motor Flanges	H	øF	k1	kit code
56 B14	197	80	109.3	KC40.4.049
63 B14	202	90	111.8	K050.4.047
71 B14	209.5	105	109.3	K050.4.045

B5 Motor Flanges	H	øF	k1	kit code
63 B5	226	138	111.8	K050.4.041
71 B5	237	160	109.3	K050.4.042

RFS10... Input Shaft
Albero in entrata

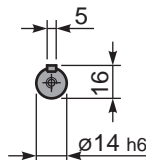
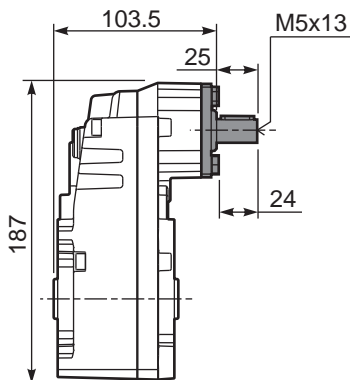



QUICK SELECTION / Selezione veloce

input speed (n_1) = 1400 min⁻¹

Output Speed n_2 [min ⁻¹]	Ratio i	Motor power P_{1M} [kW]	Output torque M_{2M} [Nm]	Service factor f.s.	Nominal power P_{1R} [kW]	Nominal torque M_{2R} [Nm]	Available B5 motor flanges		Available B14 motor flanges			Hollow Shaft 	Ratios code
							-B	-C	-O	-P	-Q		
24.2	57.95	0.25	93	1.0	0.24	90			C	C		2844	01
13.4	104.80	0.12	83	1.1	0.13	90			C	C		1954	02
11.5	121.47	0.12	96	0.9	0.12	90			C	C		1756	03
9.8	142.59	0.09	90	1.0	0.10	90			C	C		1558	04
8.2	170.20	0.06	70	1.3	0.08	90			C	C		1360	05
6.0	232.32	0.06	96	0.9	0.06	90			C	C		1063	06
4.6	303.20	0.06*	126	0.7	0.05	90			C	C		974	07
3.5	400.37	0.06*	166	0.5	0.04	90			C	C		776	08

The dynamic efficiency is **0.94** for all ratios * Power higher than the maximum one which can be supported by the gearbox. Select according to the torque M_{2R}
Potenza superiore a quella massima sopportabile dal riduttore. Selezionare in base al momento torcente M_{2R}

A Motor Flanges Available
Flange Motore Disponibili

B Supplied with Reduction Bushing
Fornito con Bussola di Riduzione

B Available on Request without reduction bushing
Disponibile a Richiesta senza Bussola di Riduzione

C Motor Flange Holes Position
Posizione Fori Flangia Motore

EN Unit **FS20** is supplied with synthetic oil for lifetime lubrication, no maintenance is necessary. See table 1 for lubrication and recommended quantity. In table 2 please see possible radial loads and axial loads on the gearbox.

I Il riduttore **FS20** viene fornito completo di olio sintetico per la lubrificazione permanente e non necessita di alcuna manutenzione. Vedi tab.1 per oli e quantità consigliati. In tab.2 sono presenti i carichi radiali e assiali applicabili al riduttore.

D Das Getriebe **FS20** ist mit synthetischem Öl gefüllt und ist lebensdauergeschmiert. In Tabelle 1 ist die Schmiermenge und das empfohlene Schmiermittel angegeben. In Tabelle 2 sind die zulässigen Radial - und Axialbelastungen des Getriebes aufgeführt.

F Le réducteur **FS20** est fourni complet avec de l'huile synthétique pour la lubrification permanente et ne nécessite aucun entretien. Voir tableau 1 concernant les huiles et les quantités conseillées. Les charges radiales et axiales applicables au réducteur sont précisées dans le tableau 2.

E El reductor tamaño **FS20** se suministra, lubricado de por vida con aceite sintético y no requiren mantenimiento alguna. Ver tabla 1, para cantidades y aceites recomendados. En la tabla 2, se encuentran las cargas radiales y axiales admitidas por el reductor.

LUBRICATION FS20 Oil Quantity 0.50 Lt.

SHELL Omala S4 WE 320

ENI Telium VSF 320

For all details on lubrication and plugs check our website **tab. 1**
Per maggiori dettagli su lubrificazione e tappi olio vedi il nostro sito web

RADIAL LOADS

Input shaft
Albero in entrata

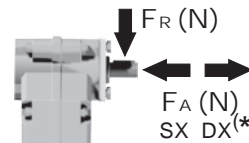

n_1	FA	FR
1400	140	700
900	160	800

*Strong axial loads in the DX direction are not allowed.
Non sono consentiti forti carichi assiali con direzione DX

tab. 2

PFS20... Basic gearbox
Riduttore base

Gearbox weight **4.3 kg**
peso riduttore

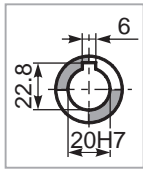

Standard
Hollow shaft

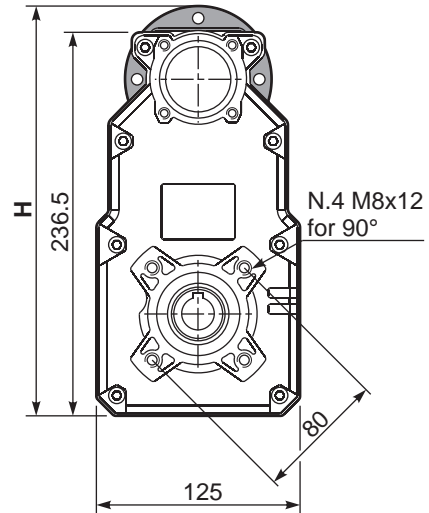
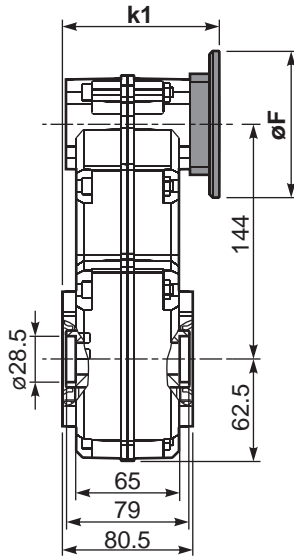

B14 Motor Flanges	H	øF	k1	kit code
56 B14	246.5	80	94.3	KC40.4.049
63 B14	251.5	90	96.8	K050.4.047
71 B14	259	105	94.3	K050.4.045

B5 Motor Flanges	H	øF	k1	kit code
63 B5	275.5	138	96.8	K050.4.041
71 B5	286.5	160	94.3	K050.4.042

RFS20... Input Shaft
Albero in entrata

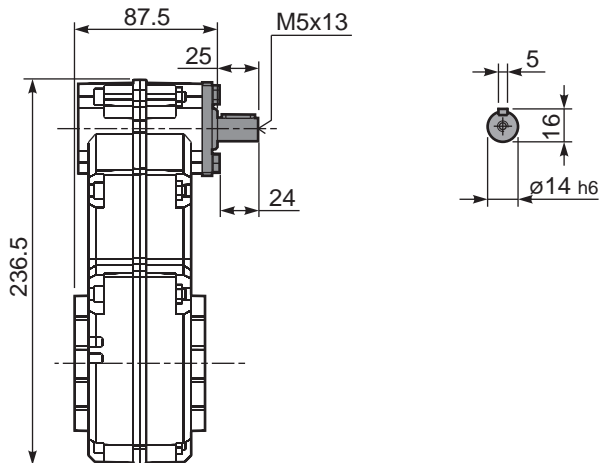



QUICK SELECTION / Selezione veloce

input speed (n_1) = 1400 min⁻¹

Output Speed n_2 [min ⁻¹]	Ratio i	Motor power P_{1M} [kW]	Output torque M_{2M} [Nm]	Service factor f.s.	Nominal power P_{1R} [kW]	Nominal torque M_{2R} [Nm]	Available B5 motor flanges					Available B14 motor flanges				Output Shaft 	Ratios code
							-B	-C	-D	-E	-F	-Q	-R	-T	-U		
							63	71	80	90	100	71	80	90	100		
231	6.06	2.2	86	0.9	2.02	80	B					C	C			2821	01
150	9.31	1.5	91	1.0	1.48	90	B					C	C			2813	02
128	10.96	1.5	107	1.0	1.53	110	B					C	C			1921	03
110	12.71	1.5	124	1.0	1.50	125	B					C	C			1721	04
94	14.91	1.5	146	1.0	1.45	142	B					C	C			1521	05
83	16.83	1.5	165	0.9	1.36	150	B					C	C			1913	06
79	17.80	1.1	127	1.2	1.29	150	B					C	C			1321	07
72	19.51	1.1	140	1.1	1.17	150	B					C	C			1713	08
61	22.90	1.1	164	0.9	1.00	150	B					C	C			1513	09
58	24.30	1.1	174	0.9	0.94	150	B					C	C			1021	10
54	26.15	0.75	128	1.2	0.88	150	B					C	C			1910	11
51	27.34	0.75	134	1.1	0.84	150	B					C	C			1313	12
46.2	30.31	0.75	149	1.0	0.76	150	B					C	C			1710	13
44.1	31.71	0.75	156	1.0	0.72	150	B					C	C			921	14
39.4	35.57	0.75	175	0.9	0.64	150	B					C	C			1510	15
37.5	37.32	0.55	135	1.1	0.61	150	B					C	C			1013	16
33.0	42.46	0.55	154	1.0	0.54	150	B					C	C			1310	17
28.7	48.70	0.55	176	0.9	0.47	150	B					C	C			913	18
24.2	57.96	0.37	140	1.1	0.40	150	B					C	C			1010	19
21.8	64.31	0.37	156	1.0	0.36	150	B					C	C			713	20
18.5	75.64	0.25	124	1.2	0.30	150	B					C	C			910	21
14.0	99.89	0.25	163	0.9	0.23	150	B					C	C			710	22

The dynamic efficiency is **0.96** for all ratios

Motor Flanges Available Flange Motore Disponibili
 B) Supplied with Reduction Bushing Fornito con Bussola di Riduzione
 B) Available on Request without reduction bushing Disponibile a Richiesta senza Bussola di Riduzione
 C) Motor Flange Holes Position Posizione Fori Flangia Motore

EN Unit **FA32** is supplied with synthetic oil for lifetime lubrication, no maintenance is necessary. See table 1 for lubrication and recommended quantity. In table 2 please see possible radial loads and axial loads on the gearbox.

I Il riduttore **FA32** viene fornito completo di olio sintetico per la lubrificazione permanente e non necessita di alcuna manutenzione. Vedi tab.1 per oli e quantità consigliati. In tab.2 sono presenti i carichi radiali e assiali applicabili al riduttore.

D Das Getriebe **FA32** ist mit synthetischem Öl gefüllt und ist lebensdauer geschmiert. In Tabelle 1 ist die Schmiermenge und das empfohlene Schmiermittel angegeben. In Tabelle 2 sind die zulässigen Radial - und Axialbelastungen des Getriebes aufgeführt.

F Le réducteur **FA32** est fourni complet avec de l'huile synthétique pour la lubrification permanente et ne nécessite aucun entretien. Voir tableau 1 concernant les huiles et les quantités conseillées. Les charges radiales et axiales applicables au réducteur sont précisées dans le tableau 2.

E El reductor tamaño **FA32** se suministra, lubricado de por vida con aceite sintético y no requieren mantenimiento alguna. Ver tabla 1, para cantidades y aceites recomendados. En la tabla 2, se encuentran las cargas radiales y axiales admitidas por el reductor.

Standard supplied	For these mounting position specify in the order or add oil				
	Per queste posizioni specificare in fase d'ordine o aggiungere olio				
H1	H4	H3	H2	H5	H6
0.65 LT	0.50 LT	0.50 LT	0.60 LT	0.80 LT	0.65 LT
SHELL Omala S4 WE 320			ENI Telium VSF 320		

For all details on lubrication and plugs check our website **tab. 1**
Per maggiori dettagli su lubrificazione e tappi olio vedi il nostro sito web

RADIAL AND AXIAL LOADS

Output shaft
Albero di uscita

$F_{eq} = FR \cdot \frac{106}{X+80}$

n_2 [min ⁻¹]	FA	FR	n_2 [min ⁻¹]	FA	FR	n_2 [min ⁻¹]	FA	FR
300	250	1250	140	360	1800	70	470	2350
250	270	1350	120	380	1900	40	550	2750
200	320	1600	85	440	2200	15	560	2800

On request reinforced bearings to increase loads.
A richiesta cuscinetti rinforzati per aumentare i carichi.

Input shaft
Albero in entrata

n_1	FA	FR
1400	240	1200
900	280	1400
500	340	1700

tab. 2

PFA32C... Basic gearbox
Riduttore base

Gearbox weight **7.0 kg**
peso riduttore

M. flanges	Kit code	øF	A
63B5	K063.4.041	140	176.5
71B5	K063.4.042	160	174.5
80/90B5	K063.4.043	200	176.5
100/112B5	KC40.4.043	250	191.5
71B14	K063.4.047	105	174.5
80B14	K063.4.046	120	176.5
90B14	K063.4.041	140	176.5
100/112B14	KC40.4.041	160	191.5

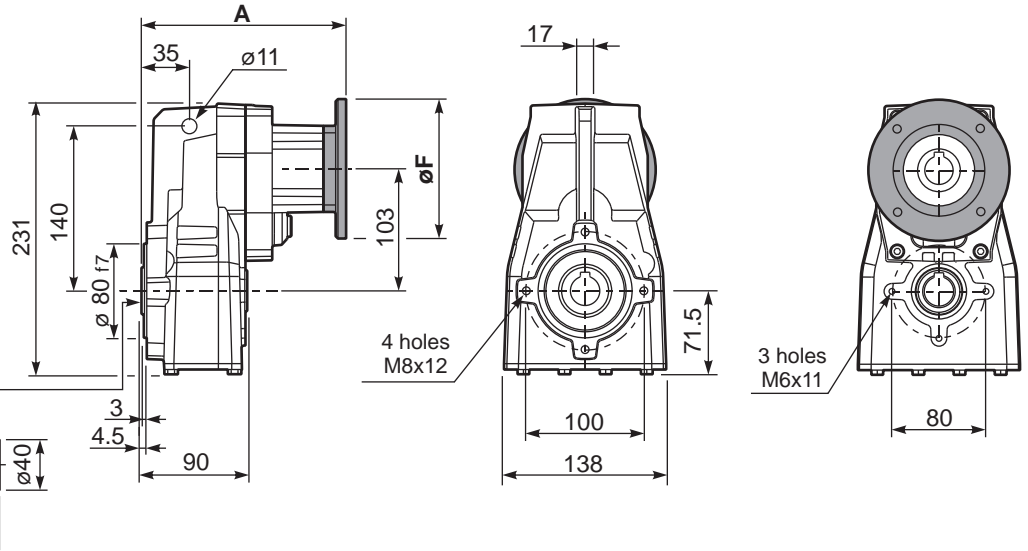

Standard
Hollow shaft

PFA32...-F... Output flange
Flangia uscita

Motor Flange	k1
63B5	208
71B5	206
80/90B5	208
100/112B5	223
71B14	206
80B14	208
90B14	208
100/112B14	223

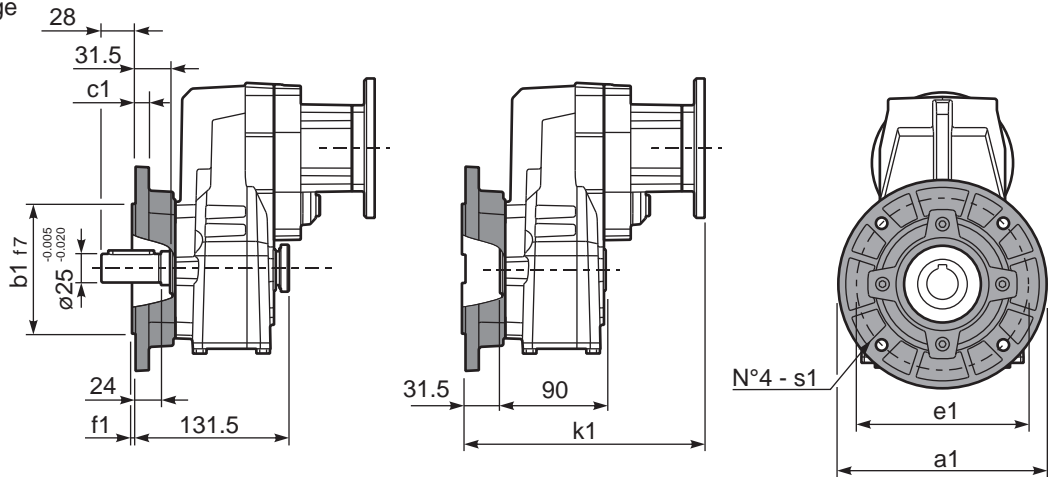

Available output flanges
Flange di uscita

a1 ø	b1	c1	e1	f1	s1	Kit code
160	110	10	130	3	9	KX4A.9.010
200	130	11	165	3.5	11	KX4A.9.011
-	-	-	-	-	-	-

RFA32C... Input Shaft
Albero in entrata

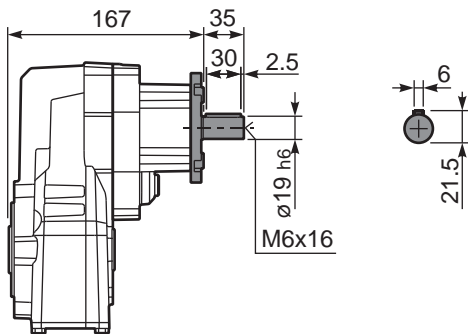

PFA32 A... Single output shaft
Albero uscita semplice

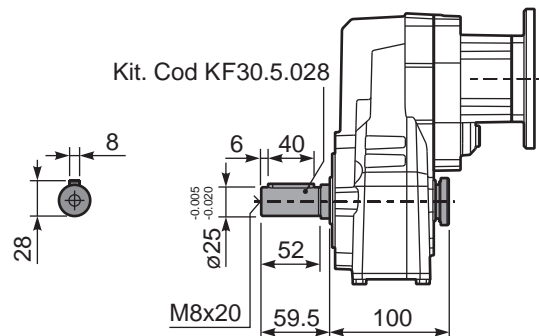



QUICK SELECTION / Selezione veloce

input speed (n_1) = 1400 min⁻¹

Output Speed n_2 [min ⁻¹]	Ratio i	Motor power P_{1M} [kW]	Output torque M_{2M} [Nm]	Service factor f.s.	Nominal power P_{1R} [kW]	Nominal torque M_{2R} [Nm]	Available B5 motor flanges		Available B14 motor flanges			Output Shaft		
							-B	-C	-O	-P	-Q			Ratios code
							63	71	56	63	71		\varnothing	
13.6	102.57	0.25	164	0,9	0.23	150			C	C		131710		01
12.6	110.77	0.18	136	1.1	0.21	150			C	C		91321		02
11.8	118.89	0.18	145	1.0	0.20	150			C	C		151310		03
10.9	128.49	0.18	157	1.0	0.18	150			C	C		101313		04
9.7	143.72	0.18	176	0.9	0.16	150			C	C		131310		05
8.7	161.67	0.12	128	1.2	0.14	150			C	C		71713		06
8.2	170.10	0.12	134	1.1	0.14	150			C	C		91313		07
7.4	188.57	0.12	149	1.0	0.12	150			C	C		91710	standard $\varnothing 25$	08
7.0	199.57	0.12	158	1.0	0.12	150			C	C		101310		09
6.2	226.51	0.09	143	1.1	0.10	150			C	C		71313		10
5.6	251.11	0.09	158	0.9	0.09	150			C	C		71710		11
5.3	264.21	0.09	167	0.9	0.09	150			C	C		91310		12
4.7	298.01	0.06	123	1.2	0.08	150			C	C		61710		13
4.0	351.82	0.06	146	1.0	0.07	150			C	C		71310		14
3.4	417.54	0.06	173	0.9	0.06	150			C	C		61310		15

The dynamic efficiency is **0.94** for all ratios

A Motor Flanges Available
Flange Motore Disponibili

B Supplied with Reduction Bushing
Fornito con Bussola di Riduzione

B Available on Request without reduction bushing
Disponibile a Richiesta senza Bussola di Riduzione

C Motor Flange Holes Position
Posizione Fori Flangia Motore

EN Unit **FA33** is supplied with synthetic oil for lifetime lubrication, no maintenance is necessary. See table 1 for lubrication and recommended quantity. In table 2 please see possible radial loads and axial loads on the gearbox.

I Il riduttore **FA33** viene fornito completo di olio sintetico per la lubrificazione permanente e non necessita di alcuna manutenzione. Vedi tab.1 per oli e quantità consigliati. In tab.2 sono presenti i carichi radiali e assiali applicabili al riduttore.

D Das Getriebe **FA33** ist mit synthetischem Öl gefüllt und ist lebensdauergeschmiert. In Tabelle 1 ist die Schmiermenge und das empfohlene Schmiermittel angegeben. In Tabelle 2 sind die zulässigen Radial - und Axialbelastungen des Getriebes aufgeführt.

F Le réducteur **FA33** est fourni complet avec de l'huile synthétique pour la lubrification permanente et ne nécessite aucun entretien. Voir tableau 1 concernant les huiles et les quantités conseillées. Les charges radiales et axiales applicables au réducteur sont précisées dans le tableau 2.

E El reductor tamaño **FA33** se suministra, lubricado de por vida con aceite sintético y no requieren mantenimiento alguna. Ver tabla 1, para cantidades y aceites recomendados. En la tabla 2, se encuentran las cargas radiales y axiales admitidas por el reductor.

Standard supplied	For these mounting position specify in the order or add oil Per queste posizioni specificare in fase d'ordine o aggiungere olio				
H1	H4	H3	H2	H5	H6
0.90 LT	0.55 LT	0.55 LT	0.65 LT	0.95 LT	0.70 LT
SHELL Omala S4 WE 320			ENI Telium VSF 320		

For all details on lubrication and plugs check our website **tab. 1**
Per maggiori dettagli su lubrificazione e tappi olio vedi il nostro sito web

RADIAL AND AXIAL LOADS

Output shaft
Albero di uscita

$F_{eq} = F_R \cdot \frac{106}{X+80}$

Input shaft
Albero in entrata

n_2 [min ⁻¹]	FA	FR	n_2 [min ⁻¹]	FA	FR	n_2 [min ⁻¹]	FA	FR
300	250	1250	140	360	1800	70	470	2350
250	270	1350	120	380	1900	40	550	2750
200	320	1600	85	440	2200	15	560	2800

On request reinforced bearings to increase loads.
A richiesta cuscinetti rinforzati per aumentare i carichi.

n_1	FA	FR
1400	140	700
900	160	800
500	190	950

tab. 2

PFA33C... Basic gearbox
Riduttore base

Gearbox weight **7.0 kg**
peso riduttore

M. flanges	Kit code	øF	A
63B5	K050.4.041	138	182
71B5	K050.4.042	160	179.5
56B14	KC40.4.049	80	179.5
63B14	K050.4.047	90	182
71B14	K050.4.045	105	179.5

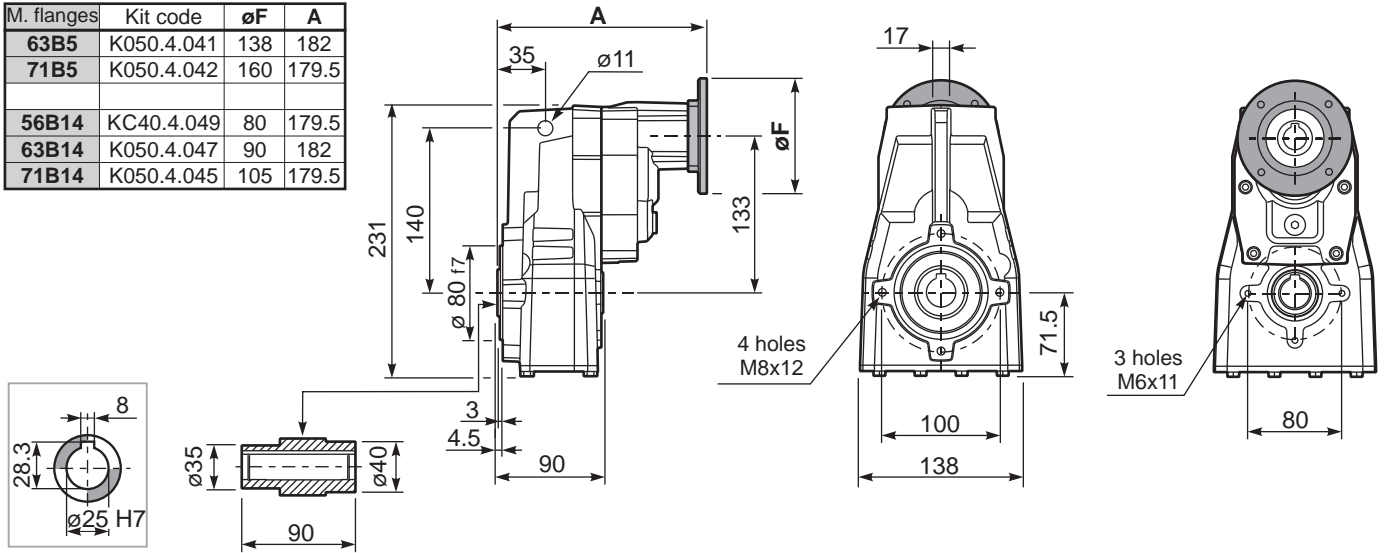

Standard
Hollow shaft

PFA33...-F... Output flange
Flangia uscita

Motor Flange	k1
63B5	213.5
71B5	211
56B14	211
63B14	213.5
71B14	211

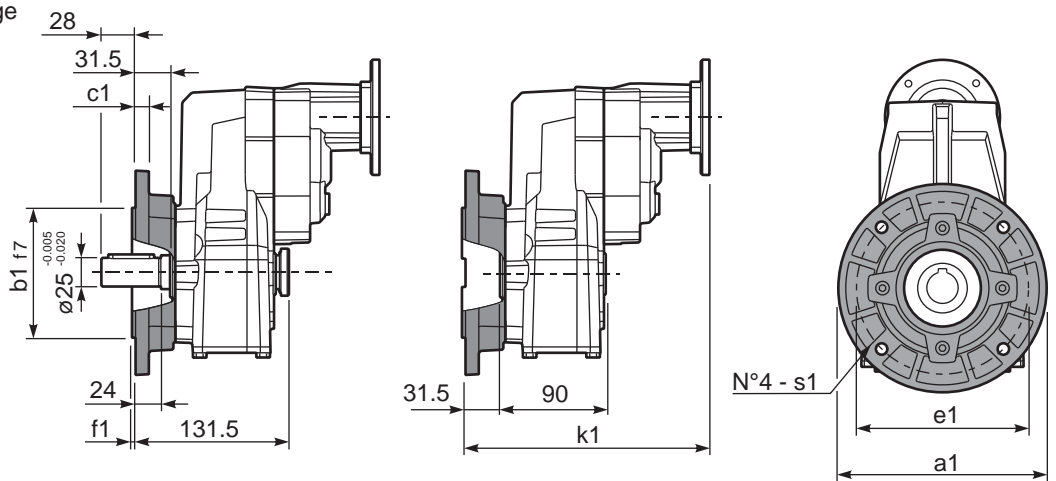

Available output flanges
Flange di uscita

a1 ø	b1	c1	e1	f1	s1	Kit code
160	110	10	130	3	9	KX4A.9.010
200	130	11	165	3.5	11	KX4A.9.011
-	-	-	-	-	-	-

RFA33C... Input Shaft
Albero in entrata

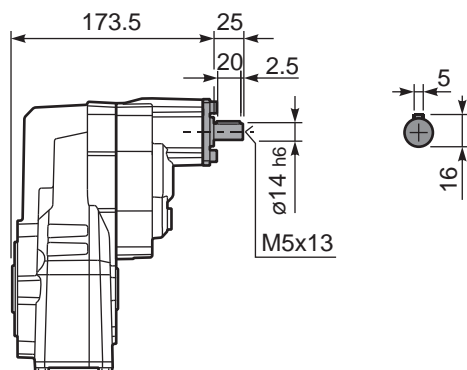

PFA33 A... Single output shaft
Albero uscita semplice

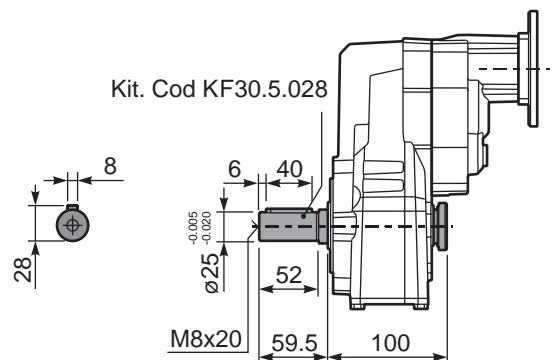



QUICK SELECTION / Selezione veloce

input speed (n_1) = 1400 min⁻¹

Output Speed n_2 [min ⁻¹]	Ratio i	Motor power P_{1M} [kW]	Output torque M_{2M} [Nm]	Service factor f.s.	Nominal power P_{1R} [kW]	Nominal torque M_{2R} [Nm]	Available B5 motor flanges			Available B14 motor flanges			Output Shaft 	Output Shaft \varnothing	Ratios code
							-D	-E	-F	-R	-T	-U			
							80	90	100 112	80	90	100 112			
481	2.91	4	76	1.8	7.2	140	B	B		B	B		3499	standard $\varnothing 30$	01
373	3.75	4	98	1.6	6.4	160	B	B		B	B		28105		02
263	5.33	4	140	1.2	4.8	170	B	B		B	B		21112		03
219	6.39	4	167	1.0	4.0	170	B	B		B	B		18115		04
178	7.85	4	205	1.1	4.3	225	B	B		B	B		13102		05

The dynamic efficiency is **0.98** for all ratios

On request

A) Motor Flanges Available
Flange Motore Disponibili

B) Supplied with Reduction Bushing
Fornito con Bussola di Riduzione

B) Available on Request without reduction bushing
Disponibile a Richiesta senza Bussola di Riduzione

C) Motor Flange Holes Position
Posizione Fori Flangia Motore

EN Unit **FA41** is supplied with synthetic oil for lifetime lubrication, no maintenance is necessary. See table 1 for lubrication and recommended quantity. In table 2 please see possible radial loads and axial loads on the gearbox.

I Il riduttore **FA41** viene fornito completo di olio sintetico per la lubrificazione permanente e non necessita di alcuna manutenzione. Vedi tab.1 per oli e quantità consigliati. In tab.2 sono presenti i carichi radiali e assiali applicabili al riduttore.

D Das Getriebe **FA41** ist mit synthetischem Öl gefüllt und ist lebensdauergeschmiert. In Tabelle 1 ist die Schmiermenge und das empfohlene Schmiermittel angegeben. In Tabelle 2 sind die zulässigen Radial - und Axialbelastungen des Getriebes aufgeführt.

F Le réducteur **FA41** est fourni complet avec de l'huile synthétique pour la lubrification permanente et ne nécessite aucun entretien. Voir tableau 1 concernant les huiles et les quantités conseillées. Les charges radiales et axiales applicables au réducteur sont précisées dans le tableau 2.

E El reductor tamaño **FA41** se suministra, lubricado de por vida con aceite sintético y no requieren mantenimiento alguna. Ver tabla 1, para cantidades y aceites recomendados. En la tabla 2, se encuentran las cargas radiales y axiales admitidas por el reductor.

Standard supplied	For these mounting position specify in the order or add oil Per queste posizioni specificare in fase d'ordine o aggiungere olio				
H1	H4	H3	H2	H5	H6
1.10 LT	0.65 LT	0.65 LT	0.65 LT	1.15 LT	0.80 LT
SHELL Omala S4 WE 320			ENI Telium VSF 320		

For all details on lubrication and plugs check our website **tab. 1**
Per maggiori dettagli su lubrificazione e tappi olio vedi il nostro sito web

RADIAL AND AXIAL LOADS

Output shaft
Albero di uscita

$F_{eq} = F_R \cdot \frac{127.5}{X+97.5}$

n_2 [min ⁻¹]	FA	FR	n_2 [min ⁻¹]	FA	FR	n_2 [min ⁻¹]	FA	FR
300	300	1500	140	390	1950	70	490	2450
250	320	1600	120	410	2050	40	590	2950
200	350	1750	85	460	2300	15	800	4000

On request reinforced bearings to increase loads.
A richiesta cuscinetti rinforzati per aumentare i carichi.

tab. 2

PFA41C... Basic gearbox
Riduttore base

Gearbox weight
peso riduttore **12.1 kg**

M. flanges	Kit code	øF	A
80/90B5	K023.4.042	200	179.5
100/112B5	K023.4.043	250	188.5
80B14	K085.4.046	120	179.5
90B14	K085.4.045	140	179.5
100/112B14	K085.4.047	160	188.5

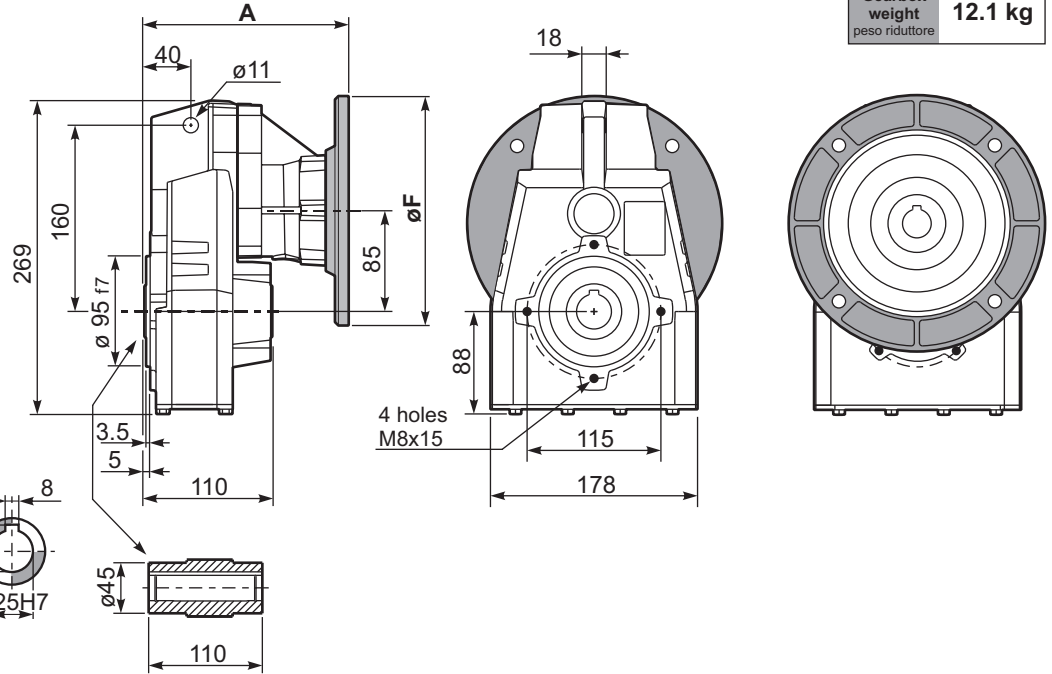

Standard
Hollow shaft

On request
A richiesta

PFA41...-F... Output flange
Flangia uscita

M. flanges	k1
80/90B5	215.5
100/112B5	221.5
80B14	213.5
90B14	213.5
100/112B14	224.5

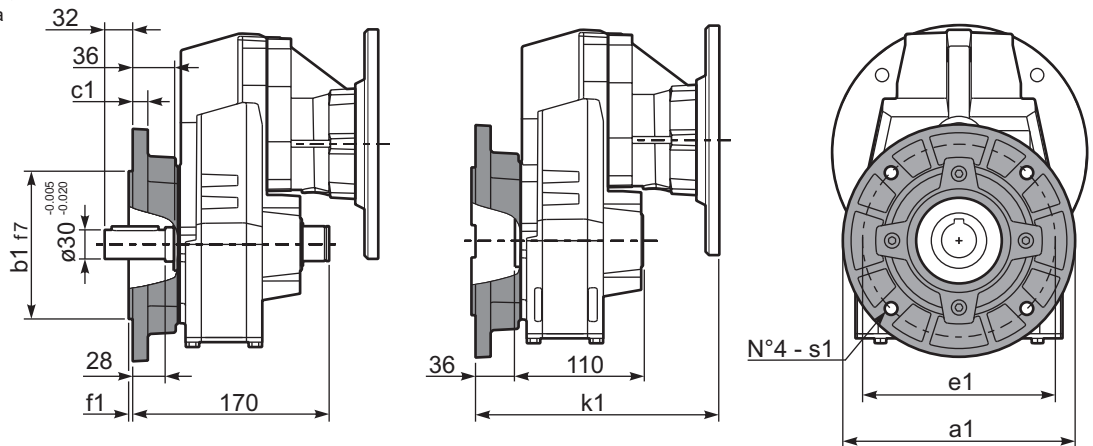

Available output flanges
Flange di uscita

a1 ø	b1	c1	e1	f1	s1	Kit code
160	110	10	130	3	9	KX5A.9.010
200	130	13	165	3.5	11	KX5A.9.011
250	180	14	215	4	14	KX5A.9.012

PFA41 A... Single output shaft
Albero uscita semplice

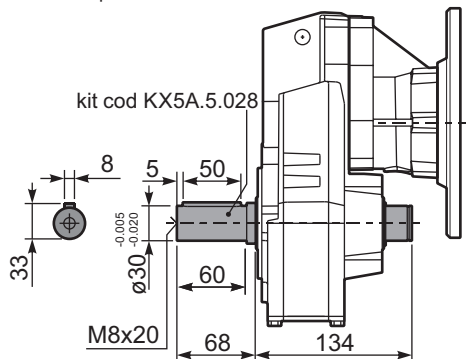



QUICK SELECTION / Selezione veloce

input speed (n₁) = 1400 min⁻¹

Output Speed n ₂ [min ⁻¹]	Ratio i	Motor power P _{1M} [kW]	Output torque M _{2M} [Nm]	Service factor f.s.	Nominal power P _{1R} [kW]	Nominal torque M _{2R} [Nm]	Available B5 motor flanges					Available B14 motor flanges				Output Shaft	Ratios code
							-B	-C	-D	-E	-F	-Q	-R	-T	-U		
							63	71	80	90	100	112	71	80	90		
167	8.38	4	215	1.0	4.1	225	B					C	C			2821	01
139	10.04	3	194	1.2	3.7	240	B					C	C	C		2818	02
114	12.33	3	238	1.1	3.2	260	B					C	C	C		2813	03
92	15.16	2.2	215	1.2	2.6	260	B					C	C	C		1921	04
80	17.57	2.2	250	1.1	2.3	270	B					C	C	C		1721	05
77	18.16	2.2	258	1.1	2.4	290	B					C	C	C		1918	06
67	21.05	2.2	299	1.1	2.3	320	B					C	C	C		1718	07
63	22.30	2.2	317	1.0	2.2	320	B					C	C	C		1913	08
57	24.70	1.5	242	1.3	2.0	320	B					C	C	C		1518	09
54	25.85	1.5	253	1.3	1.9	320	B					C	C	C		1713	10
47.5	29.49	1.5	289	1.1	1.7	320	B					C	C	C		1318	11
46.1	30.34	1.5	297	1.1	1.6	320	B					C	C	C		1513	12
41.7	33.60	1.1	240	1.0	1.1	250	B					C	C	C		1021	13
38.7	36.21	1.1	259	1.2	1.3	320	B					C	C	C		1313	14
34.8	40.25	1.1	288	1.0	1.1	300	B					C	C	C		1018	15
28.3	49.43	1.1	354	0.9	0.99	320	B					C	C	C		1013	16
26.7	52.53	0.75	258	1.0	0.76	260	B					C	C	C		918	17
21.7	64.51	0.75	317	1.0	0.75	315	B					C	C	C		913	18
20.2	69.37	0.37	168	1.1	0.42	190	B					C	C	C		718	19
16.4	85.19	0.37	206	1.1	0.41	230	B					C	C	C		713	20

The dynamic efficiency is **0.96** for all ratios

Motor Flanges Available
Flange Motore Disponibili

Supplied with Reduction Bushing
Fornito con Bussola di Riduzione

Available on Request without reduction bushing
Disponibile a Richiesta senza Bussola di Riduzione

Motor Flange Holes Position
Posizione Fori Flangia Motore

EN Unit **FA42** is supplied with synthetic oil for lifetime lubrication, no maintenance is necessary. See table 1 for lubrication and recommended quantity. In table 2 please see possible radial loads and axial loads on the gearbox.

I Il riduttore **FA42** viene fornito completo di olio sintetico per la lubrificazione permanente e non necessita di alcuna manutenzione. Vedi tab.1 per oli e quantità consigliati. In tab.2 sono presenti i carichi radiali e assiali applicabili al riduttore.

D Das Getriebe **FA42** ist mit synthetischem Öl gefüllt und ist lebensdauergeschmiert. In Tabelle 1 ist die Schmiermenge und das empfohlene Schmiermittel angegeben. In Tabelle 2 sind die zulässigen Radial - und Axialbelastungen des Getriebes aufgeführt.

F Le réducteur **FA42** est fourni complet avec de l'huile synthétique pour la lubrification permanente et ne nécessite aucun entretien. Voir tableau 1 concernant les huiles et les quantités conseillées. Les charges radiales et axiales applicables au réducteur sont précisées dans le tableau 2.

E El reductor tamaño **FA42** se suministra, lubricado de por vida con aceite sintético y no requieren mantenimiento alguna. Ver tabla 1, para cantidades y aceites recomendados. En la tabla 2, se encuentran las cargas radiales y axiales admitidas por el reductor.

Standard supplied	For these mounting position specify in the order or add oil Per queste posizioni specificare in fase d'ordine o aggiungere olio				
H1	H4	H3	H2	H5	H6
1.15 LT	0.70 LT	0.70 LT	0.70 LT	1.20 LT	0.80 LT
SHELL Omala S4 WE 320			ENI Telium VSF 320		

For all details on lubrication and plugs check our website **tab. 1**
Per maggiori dettagli su lubrificazione e tappi olio vedi il nostro sito web

RADIAL AND AXIAL LOADS

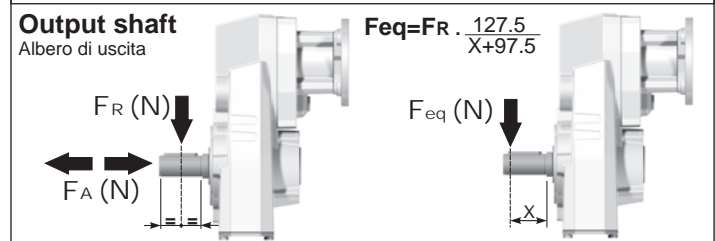

n ₂ [min ⁻¹]	FA	FR	n ₂ [min ⁻¹]	FA	FR	n ₂ [min ⁻¹]	FA	FR
300	300	1500	140	390	1950	70	490	2450
250	320	1600	120	410	2050	40	590	2950
200	350	1750	85	460	2300	15	800	4000

On request reinforced bearings to increase loads.
A richiesta cuscinetti rinforzati per aumentare i carichi.

Input shaft Albero in entrata	n ₁	FA	FR
	1400	240	1200
	900	280	1400
	500	340	1700

tab. 2

PFA42C... Basic gearbox
Riduttore base

Gearbox weight
peso riduttore **9.0 kg**

M. flanges	Kit code	øF	A
63B5	K063.4.041	140	169.5
71B5	K063.4.042	160	167.5
80/90B5	K063.4.043	200	169.5
100/112B5	KC40.4.043	250	184.5
71B14	K063.4.047	105	167.5
80B14	K063.4.046	120	169.5
90B14	K063.4.041	140	169.5
100/112B14	KC40.4.041	160	184.5

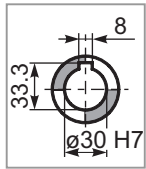
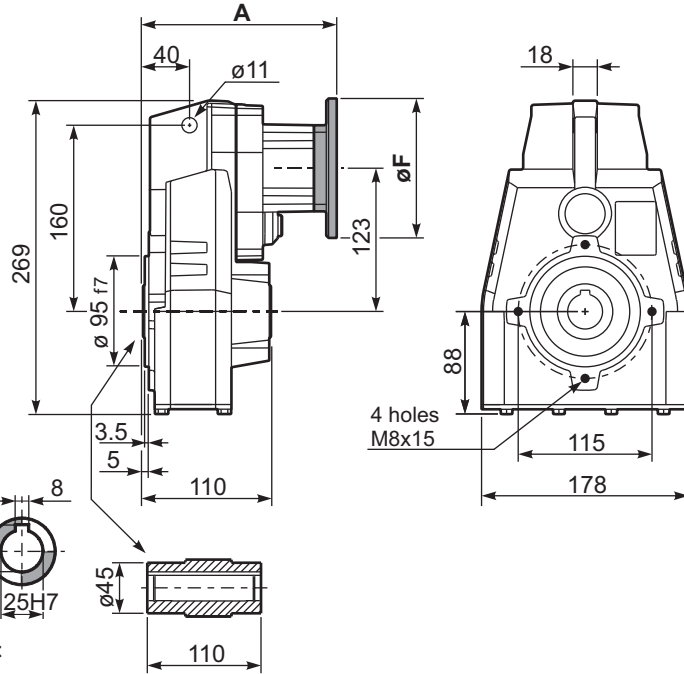

Standard
Hollow shaft

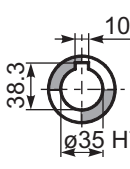

On request
A richiesta

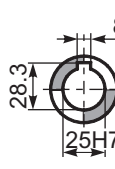

PFA42...-F... Output flange
Flangia uscita

Motor Flange	k1
63B5	205.5
71B5	203.5
80/90B5	205.5
100/112B5	220.5
71B14	203.5
80B14	205.5
90B14	205.5
100/112B14	220.5

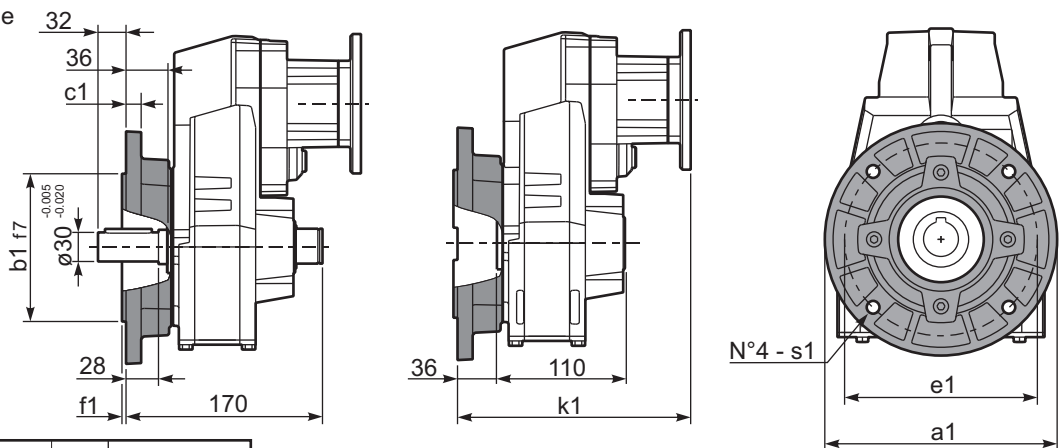

Available output flanges
Flange di uscita

a1 ø	b1	c1	e1	f1	s1	Kit code
160	110	10	130	3	9	KX5A.9.010
200	130	13	165	3.5	11	KX5A.9.011
250	180	14	215	4	14	KX5A.9.012

RFA42C... Input Shaft
Albero in entrata

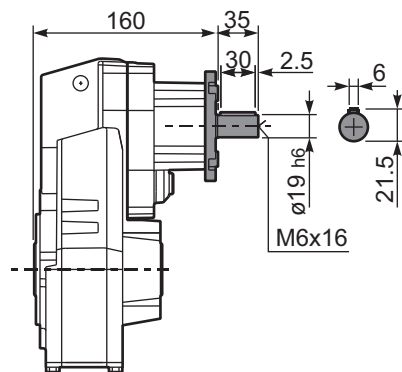

PFA42 A... Single output shaft
Albero uscita semplice

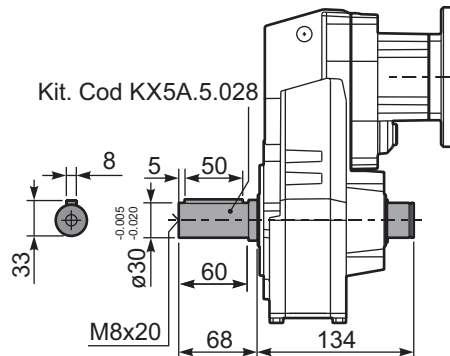

PFA42D... Shrink disk
Calettatore

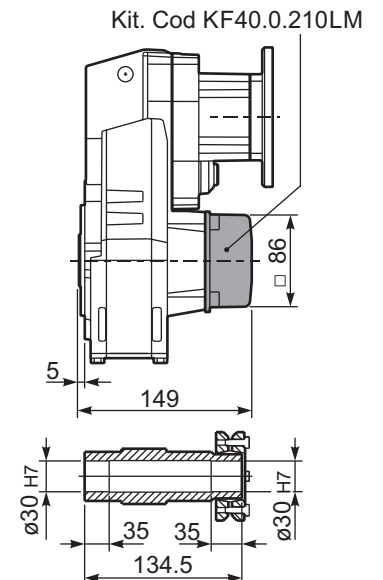



QUICK SELECTION / Selezione veloce

input speed (n_1) = 1400 min⁻¹

Output Speed n_2 [min ⁻¹]	Ratio i	Motor power P_{1M} [kW]	Output torque M_{2M} [Nm]	Service factor f.s.	Nominal power P_{1R} [kW]	Nominal torque M_{2R} [Nm]	Available B5 motor flanges		Available B14 motor flanges			Output Shaft 	Ratios code
							-B	-C	-O	-P	-Q		
							63	71	56	63	71		
18.8	74.33	0.37	176	1.8	0.67	320			C	C		191313	01
17.0	82.56	0.37	196	1.6	0.60	320			C	C		151318	02
16.0	87.48	0.37	207	1.5	0.57	320			C	C		131713	03
13.8	101.40	0.37	240	1.3	0.49	320			C	C		151313	04
11.4	122.57	0.37	291	1.1	0.41	320			C	C		131313	05
10.1	138.59	0.37	329	1.0	0.36	320			C	C		101318	06
8.7	160.82	0.25	257	1.2	0.31	320			C	C		91713	07
8.2	170.20	0.25	272	1.2	0.29	320			C	C		101313	08
7.6	183.48	0.25	294	1.1	0.27	320			C	C		91318	09
6.5	214.15	0.18	262	1.2	0.23	320			C	C		71713	10
6.2	225.33	0.18	276	1.2	0.22	320			C	C		91313	11
5.7	244.32	0.18	299	1.1	0.20	320			C	C		71318	12
5.5	254.15	0.18	311	1.0	0.20	320			C	C		61713	13
4.8	289.96	0.18	355	0.9	0.17	320			C	C		61318	14
4.7	300.05	0.18	367	0.9	0.17	320			C	C		71313	15
3.9	356.09	0.12	282	1.1	0.14	320			C	C		61313	16

The dynamic efficiency is **0.94** for all ratios

Motor Flanges Available
Flange Motore Disponibili

B) Supplied with Reduction Bushing
Fornito con Bussola di Riduzione

B) Available on Request without reduction bushing
Disponibile a Richiesta senza Bussola di Riduzione

C) Motor Flange Holes Position
Posizione Fori Flangia Motore

EN Unit **FA43** is supplied with synthetic oil for lifetime lubrication, no maintenance is necessary. See table 1 for lubrication and recommended quantity. In table 2 please see possible radial loads and axial loads on the gearbox.

I Il riduttore **FA43** viene fornito completo di olio sintetico per la lubrificazione permanente e non necessita di alcuna manutenzione. Vedi tab.1 per oli e quantità consigliati. In tab.2 sono presenti i carichi radiali e assiali applicabili al riduttore.

D Das Getriebe **FA43** ist mit synthetischem Öl gefüllt und ist lebensdauergeschmiert. In Tabelle 1 ist die Schmiermenge und das empfohlene Schmiermittel angegeben. In Tabelle 2 sind die zulässigen Radial - und Axialbelastungen des Getriebes aufgeführt.

F Le réducteur **FA43** est fourni complet avec de l'huile synthétique pour la lubrification permanente et ne nécessite aucun entretien. Voir tableau 1 concernant les huiles et les quantités conseillées. Les charges radiales et axiales applicables au réducteur sont précisées dans le tableau 2.

E El reductor tamaño **FA43** se suministra, lubricado de por vida con aceite sintético y no requieren mantenimiento alguna. Ver tabla 1, para cantidades y aceites recomendados. En la tabla 2, se encuentran las cargas radiales y axiales admitidas por el reductor.

Standard supplied	For these mounting position specify in the order or add oil				
	Per queste posizioni specificare in fase d'ordine o aggiungere olio				
H1	H4	H3	H2	H5	H6
1.30 LT	0.70 LT	0.70 LT	0.70 LT	1.35 LT	0.90 LT
SHELL Omala S4 WE 320			ENI Telium VSF 320		

For all details on lubrication and plugs check our website **tab. 1**
Per maggiori dettagli su lubrificazione e tappi olio vedi il nostro sito web

RADIAL AND AXIAL LOADS



n_2 [min ⁻¹]	FA	FR	n_2 [min ⁻¹]	FA	FR	n_2 [min ⁻¹]	FA	FR
300	300	1500	140	390	1950	70	490	2450
250	320	1600	120	410	2050	40	590	2950
200	350	1750	85	460	2300	15	800	4000

On request reinforced bearings to increase loads.

A richiesta cuscinetti rinforzati per aumentare i carichi.

Input shaft Albero di entrata	n_1	FA	FR
	1400	140	700
	900	160	800
	500	190	950

tab. 2

PFA43C... Basic gearbox
Riduttore base

Gearbox weight
peso riduttore **8.9 kg**

M. flanges	Kit code	øF	A
63B5	K050.4.041	138	175
71B5	K050.4.042	160	172.5
56B14	KC40.4.049	80	172.5
63B14	K050.4.047	90	175
71B14	K050.4.045	105	172.5

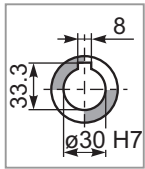
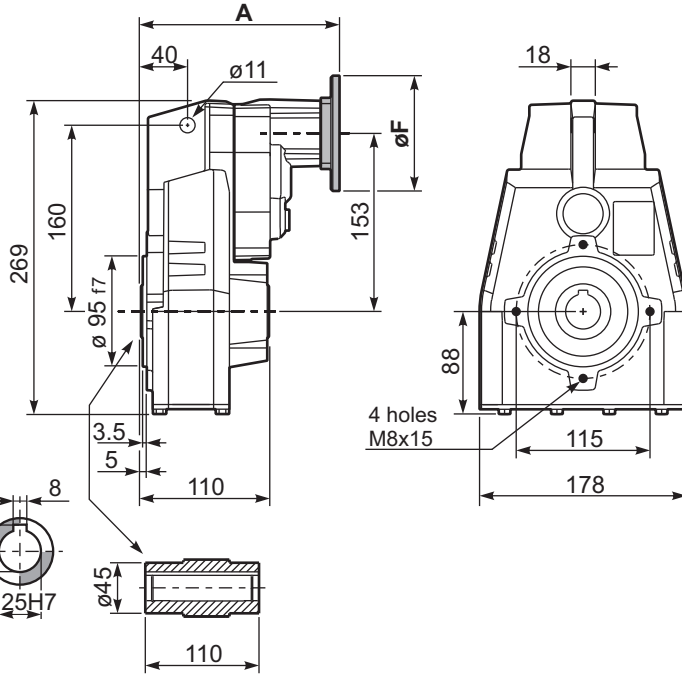

Standard
Hollow shaft

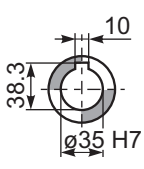

On request
A richiesta

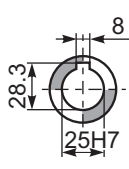

PFA43...-F... Output flange
Flangia uscita

Motor Flange	k1
63B5	211
71B5	208.5
56B14	208.5
63B14	211
71B14	208.5

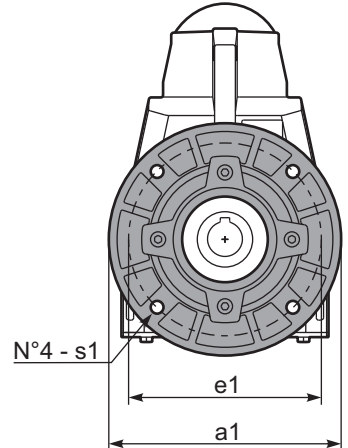
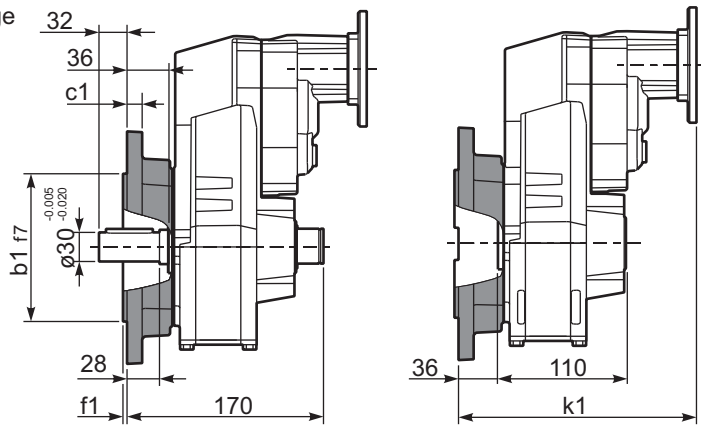

Available output flanges
Flange di uscita

a1 ø	b1	c1	e1	f1	s1	Kit code
160	110	10	130	3	9	KX5A.9.010
200	130	13	165	3.5	11	KX5A.9.011
250	180	14	215	4	14	KX5A.9.012

RFA43C... Input Shaft
Albero in entrata

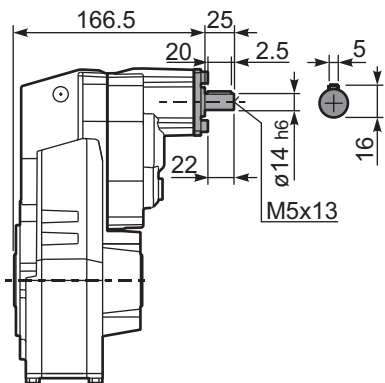

PFA43 A... Single output shaft
Albero uscita semplice

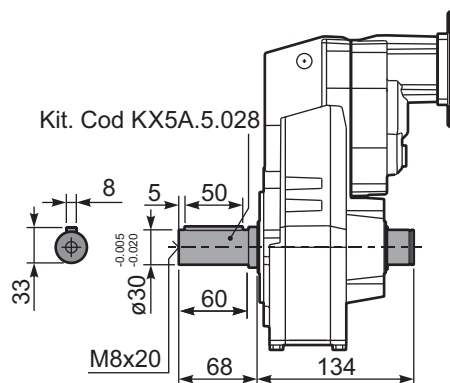

PFA43D... Shrink disk
Calettatore

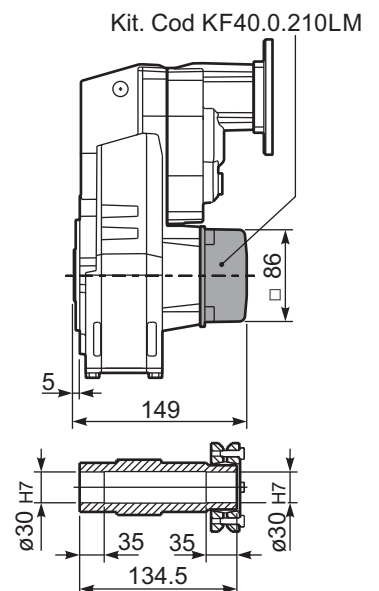



QUICK SELECTION / Selezione veloce

input speed (n_1) = 1400 min⁻¹

Output Speed n_2 [min ⁻¹]	Ratio i	Motor power P_{1M} [kW]	Output torque M_{2M} [Nm]	Service factor f.s.	Nominal power P_{1R} [kW]	Nominal torque M_{2R} [Nm]	Available B5 motor flanges					Available B14 motor flanges				Output Shaft 	Ratios code
							-C	-D	-E	-F	-G	-R	-T	-U	-V		
							71	80	90	100	112	80	90	100	112		
213	6.57	5.5	230	1.2	6.5	280	B									3018	01
185	7.56	5.5	265	1.1	5.9	290	B									3016	02
159	8.82	5.5	309	1.0	5.5	320	B									3014	03
113	12.39	5.5	434	1.0	5.5	450	B									2018	04
98	14.24	5.5	499	0.9	4.8	450	B									2016	05
84	16.75	4	429	1.1	4.3	470	B									1618	06
73	19.25	4	494	1.0	3.9	490	B									1616	07
64	21.78	4	558	0.9	3.4	490	B									1318	08
56	25.04	3	483	1.0	3.0	490	B									1316	09
47.9	29.23	3	564	0.9	2.6	490	B									1314	10
45.7	30.65	2.2	436	1.1	2.4	490	B									1116	11
39.1	35.78	2.2	509	1.0	2.1	490	B									1114	12
36.3	38.55	2.2	548	0.9	1.9	490	B									818	13
31.6	44.32	1.5	434	1.1	1.7	490	B									816	14
27.1	51.74	1.5	507	1.0	1.4	490	B									814	15
22.9	61.03	1.1	437	1.1	1.2	480	B									616	16
19.6	71.25	1.1	510	1.0	1.1	490	B									614	17

The dynamic efficiency is **0.96** for all ratios

- Motor Flanges Available
Flange Motore Disponibili
- B) Supplied with Reduction Bushing
Fornito con Bussola di Riduzione
- B) Available on Request without reduction bushing
Disponibile a Richiesta senza Bussola di Riduzione
- C) Motor Flange Holes Position
Posizione Fori Flangia Motore

EN Unit FA52 is supplied with synthetic oil for lifetime lubrication, no maintenance is necessary. See table 1 for lubrication and recommended quantity. In table 2 please see possible radial loads and axial loads on the gearbox.

I Il riduttore FA52 viene fornito completo di olio sintetico per la lubrificazione permanente e non necessita di alcuna manutenzione. Vedi tab.1 per oli e quantità consigliati. In tab.2 sono presenti i carichi radiali e assiali applicabili al riduttore.

D Das Getriebe FA52 ist mit synthetischem Öl gefüllt und ist lebensdauergeschmiert. In Tabelle 1 ist die Schmiermenge und das empfohlene Schmiermittel angegeben. In Tabelle 2 sind die zulässigen Radial - und Axialbelastungen des Getriebes aufgeführt.

F Le réducteur FA52 est fourni complet avec de l'huile synthétique pour la lubrification permanente et ne nécessite aucun entretien. Voir tableau 1 concernant les huiles et les quantités conseillées. Les charges radiales et axiales applicables au réducteur sont précisées dans le tableau 2.

E El reductor tamaño FA52 se suministra, lubricado de por vida con aceite sintético y no requieren mantenimiento alguna. Ver tabla 1, para cantidades y aceites recomendados. En la tabla 2, se encuentran las cargas radiales y axiales admitidas por el reductor.

Standard supplied	For these mounting position specify in the order or add oil Per queste posizioni specificare in fase d'ordine o aggiungere olio				
H1	H4	H3	H2	H5	H6
1.85 LT	1.15 LT	1.15 LT	1.30 LT	2.10 LT	1.30 LT
SHELL Omala S4 WE 320			ENI Telium VSF 320		

For all details on lubrication and plugs check our website **tab. 1**
Per maggiori dettagli su lubrificazione e tappi olio vedi il nostro sito web

RADIAL AND AXIAL LOADS

Output shaft
Albero di uscita

$F_{eq} = FR \cdot \frac{149.5}{X+119.5}$

n_2	FA	FR	n_2	FA	FR	n_2	FA	FR
300	400	2000	140	460	2300	70	580	2900
250	420	2100	120	500	2500	40	780	3900
200	440	2200	85	550	2750	15	1140	5700

On request reinforced bearings to increase loads.
A richiesta cuscinetti rinforzati per aumentare i carichi.

Input shaft
Albero di entrata

n_1	FA	FR
1400	400	2000
900	440	2200
500	440	2200

tab. 2

PFA52C... Basic gearbox
Riduttore base

Gearbox weight
peso riduttore **15.5 kg**

M. flanges	Kit code	øF	A
71B5	K023.4.041	160	227
80/90B5	K023.4.042	200	229
100/112B5	K023.4.043	250	238
132B5	KC51.4.043	300	259
80B14	K085.4.046	120	229
90B14	K085.4.045	140	229
100/112B14	K085.4.047	160	238
132B14	KC51.4.041	200	259

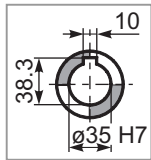
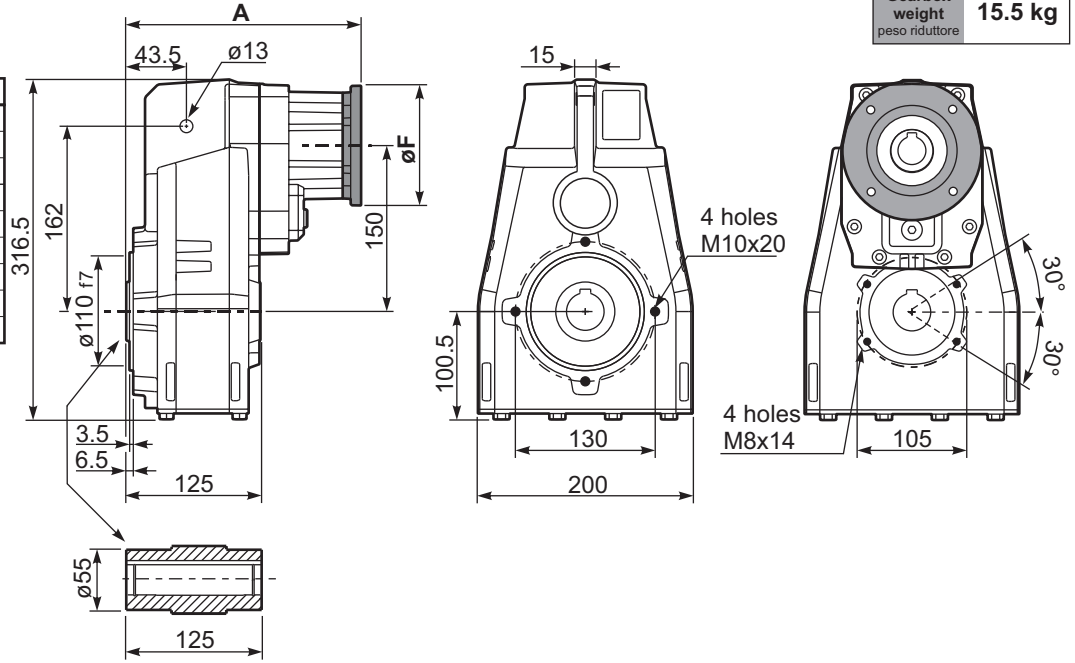

Standard
Hollow shaft

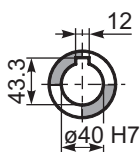

On request
A richiesta

PFA52...-F... Output flange
Flangia uscita

M. flanges	k1
71B5	260
80/90B5	262
100/112B5	271
132B5	289
80B14	262
90B14	262
100/112B14	271
132B14	289

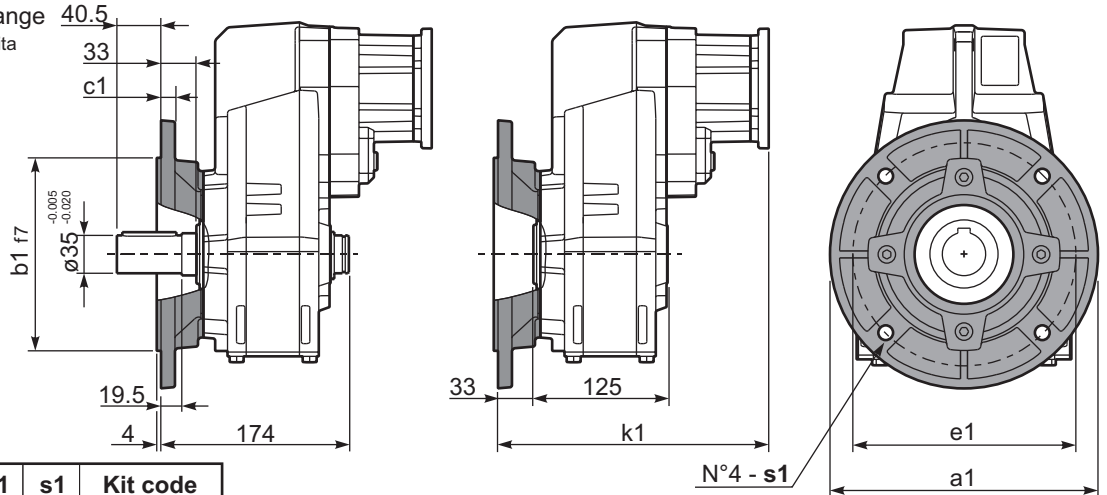

Available output flanges
Flange di uscita

a1 ø	b1	c1	e1	s1	Kit code
250	180	13	215	14	KF60.9.011
-	-	-	-	-	-

RFA52C... Input Shaft
Albero in entrata

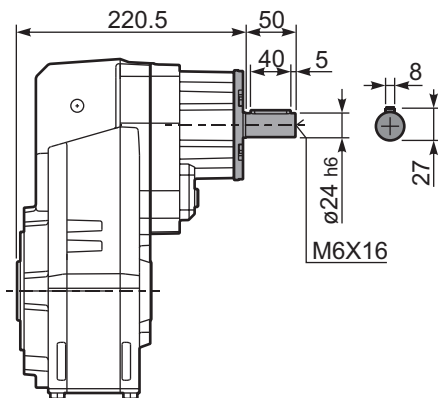

PFA52 A... Single output shaft
Albero uscita semplice

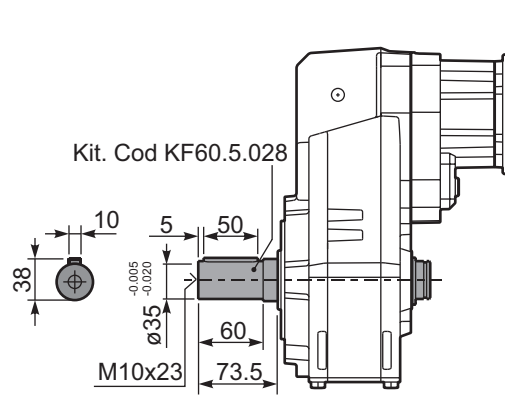

PFA52D... Shrink disk
Calettatore

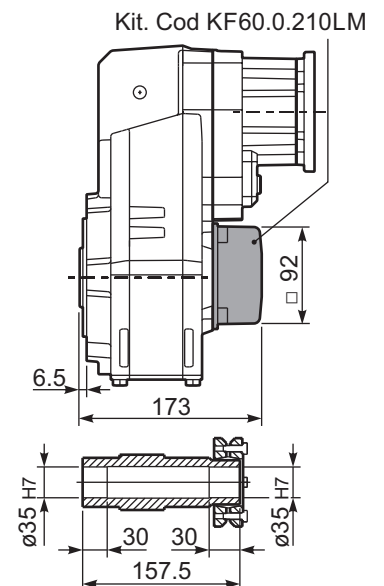



QUICK SELECTION / Selezione veloce

input speed (n_1) = 1400 min⁻¹

Output Speed n_2 [min ⁻¹]	Ratio i	Motor power P_{1M} [kW]	Output torque M_{2M} [Nm]	Service factor f.s.	Nominal power P_{1R} [kW]	Nominal torque M_{2R} [Nm]	Available B5 motor flanges				Available B14 motor flanges			Output Shaft 	Ratios code
							-B	-C	-D	-E	-Q	-R	-T		
							63	71	80	90	71	80	90		
22.6	61.89	1.1	434	1.2	1.3	510	B				C	C		191318	01
19.7	71.16	1.1	499	1.0	1.1	510	B				C	C		191316	02
17.0	82.48	1.1	578	0.9	0.96	510	B				C	C		171316	03
14.5	96.29	0.75	463	1.1	0.83	510	B				C	C		171314	04
13.9	100.51	0.75	483	1.1	0.79	510	B				C	C		131318	05
12.1	115.56	0.55	410	1.2	0.69	510	B				C	C		131316	06
11.1	125.96	0.55	447	1.1	0.63	510	B				C	C		190816	07
10.4	134.91	0.55	479	1.1	0.59	510	B				C	C		131314	08
9.5	147.05	0.55	522	1.0	0.54	510	B				C	C		190814	09
8.2	170.44	0.37	404	1.3	0.47	510	B				C	C		170814	10
7.6	184.15	0.37	437	1.2	0.43	510	B				C	C		101314	11
6.8	205.87	0.37	488	1.0	0.39	510	B				C	C		91316	12
5.8	240.34	0.37	570	0.9	0.33	510	B				C	C		91314	13
5.0	279.22	0.25	447	1.1	0.28	510	B				C	C		100816	14
4.3	325.97	0.25	522	1.0	0.24	510	B				C	C		100814	15
3.8	364.41	0.18	446	1.1	0.22	510	B				C	C		90816	16
3.3	425.43	0.18	521	1.0	0.19	510	B				C	C		90814	17
2.9	481.19	0.18	589	0.9	0.17	510	B				C	C		70816	18
2.5	561.76	0.12	444	1.1	0.14	510	B				C	C		70814	19

The dynamic efficiency is **0.94** for all ratios

- Motor Flanges Available**
Flange Motore Disponibili
- B) Supplied with Reduction Bushing**
Fornito con Bussola di Riduzione
- B) Available on Request without reduction bushing**
Disponibile a Richiesta senza Bussola di Riduzione
- C) Motor Flange Holes Position**
Posizione Fori Flangia Motore

EN Unit **FA53** is supplied with synthetic oil for lifetime lubrication, no maintenance is necessary. See table 1 for lubrication and recommended quantity. In table 2 please see possible radial loads and axial loads on the gearbox.

I Il riduttore **FA53** viene fornito completo di olio sintetico per la lubrificazione permanente e non necessita di alcuna manutenzione. Vedi tab.1 per oli e quantità consigliati. In tab.2 sono presenti i carichi radiali e assiali applicabili al riduttore.

D Das Getriebe **FA53** ist mit synthetischem Öl gefüllt und ist lebensdauergeschmiert. In Tabelle 1 ist die Schmiermenge und das empfohlene Schmiermittel angegeben. In Tabelle 2 sind die zulässigen Radial - und Axialbelastungen des Getriebes aufgeführt.

F Le réducteur **FA53** est fourni complet avec de l'huile synthétique pour la lubrification permanente et ne nécessite aucun entretien. Voir tableau 1 concernant les huiles et les quantités conseillées. Les charges radiales et axiales applicables au réducteur sont précisées dans le tableau 2.

E El reductor tamaño **FA53** se suministra, lubricado de por vida con aceite sintético y no requieren mantenimiento alguna. Ver tabla 1, para cantidades y aceites recomendados. En la tabla 2, se encuentran las cargas radiales y axiales admitidas por el reductor.

Standard supplied	For these mounting position specify in the order or add oil Per queste posizioni specificare in fase d'ordine o aggiungere olio				
H1	H4	H3	H2	H5	H6
2.15 LT	1.25 LT	1.25 LT	1.45 LT	2.35 LT	1.45 LT
SHELL Omala S4 WE 320			ENI Telium VSF 320		

For all details on lubrication and plugs check our website **tab. 1**
Per maggiori dettagli su lubrificazione e tappi olio vedi il nostro sito web

RADIAL AND AXIAL LOADS

Output shaft
Albero di uscita

$F_{eq} = F_R \cdot \frac{149.5}{X+119.5}$

n_2	FA	FR	n_2	FA	FR	n_2	FA	FR
300	400	2000	140	460	2300	70	580	2900
250	420	2100	120	500	2500	40	780	3900
200	440	2200	85	550	2750	15	1140	5700

On request reinforced bearings to increase loads.
A richiesta cuscinetti rinforzati per aumentare i carichi.

Input shaft
Albero in entrata

n_1	FA	FR
1400	240	1200
900	280	1400
500	340	1700

tab. 2

PFA53C... Basic gearbox
Riduttore base

Gearbox weight
peso riduttore **15.5 kg**

M. flanges	Kit code	øF	A
63B5	K063.4.041	140	239
71B5	K063.4.042	160	237
80/90B5	K063.4.043	200	239
71B14	K063.4.047	105	237
80B14	K063.4.046	120	239
90B14	K063.4.041	140	239

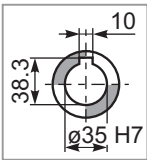
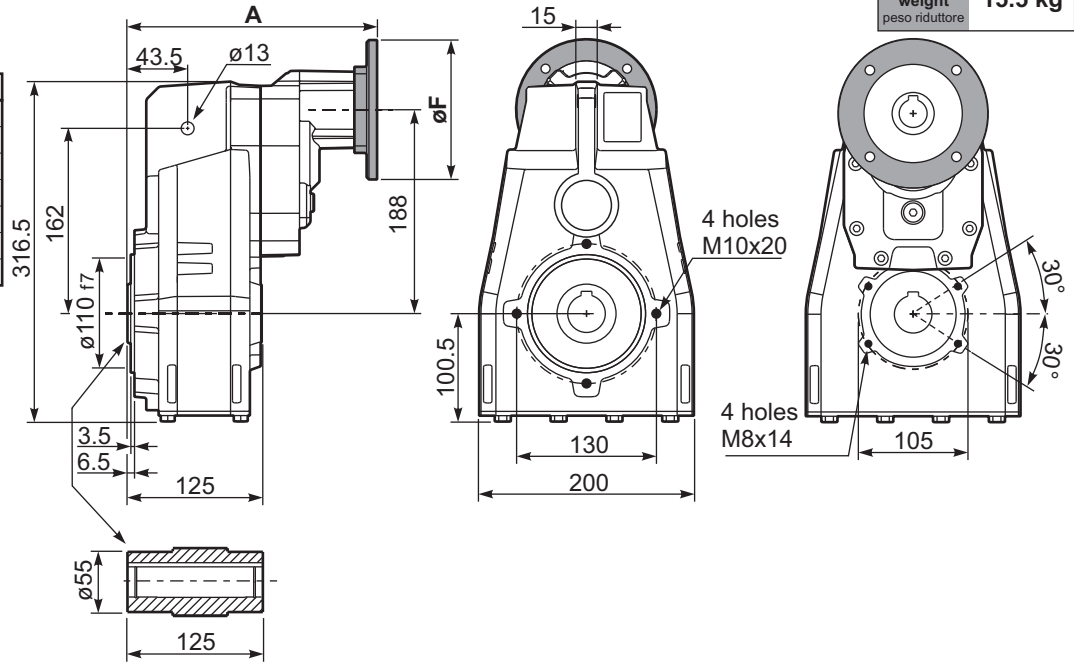

Standard
Hollow shaft

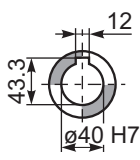

On request
A richiesta

PFA53...-F... Output flange
Flangia uscita

Motor Flange	k1
63B5	272
71B5	270
80/90B5	272
71B14	270
80B14	272
90B14	272

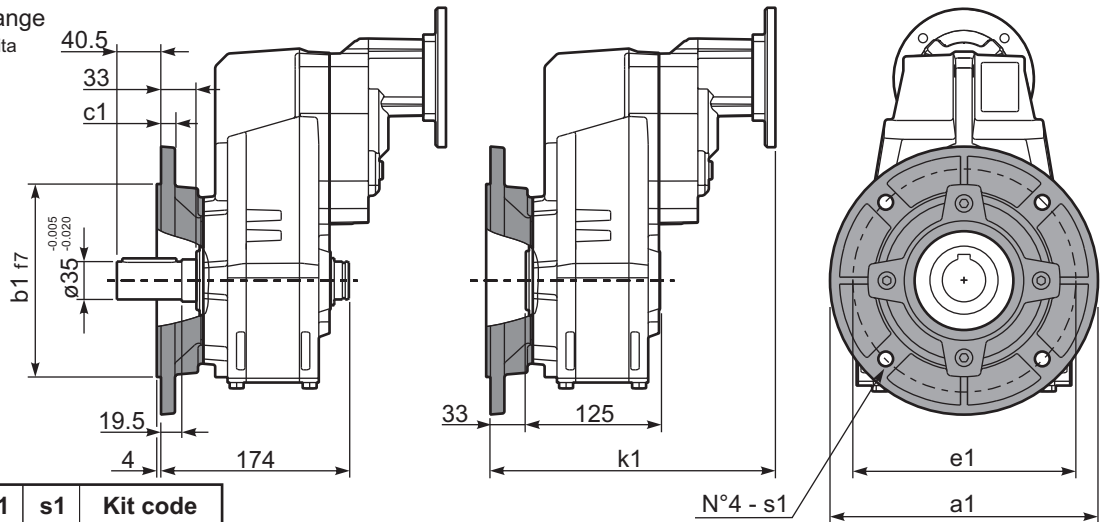

Available output flanges

Flange di uscita

a1 ø	b1	c1	e1	s1	Kit code
250	180	13	215	14	KF60.9.011
-	-	-	-	-	-

RFA53C... Input Shaft
Albero in entrata

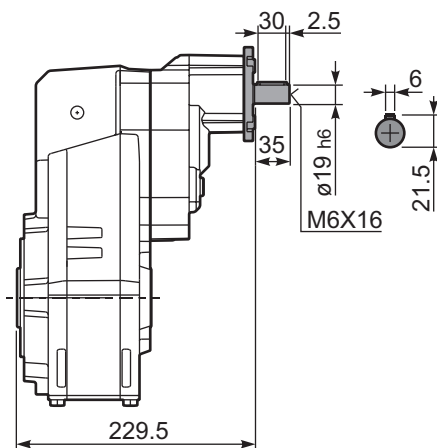

PFA53 A... Single output shaft
Albero uscita semplice

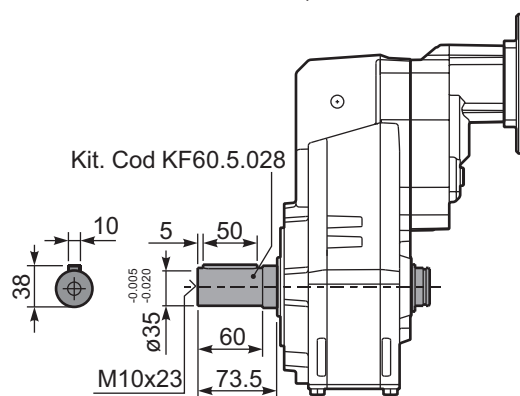

PFA53D... Shrink disk
Calettatore

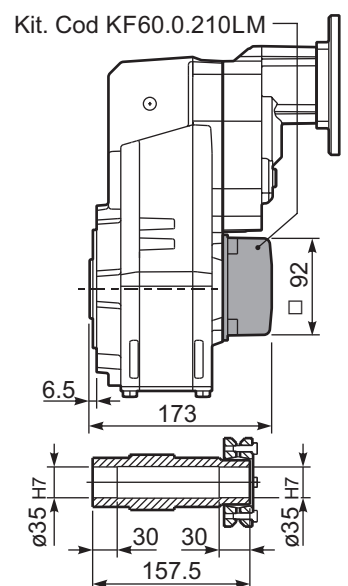



QUICK SELECTION / Selezione veloce

input speed (n_1) = 1400 min⁻¹

Output Speed n_2 [min ⁻¹]	Ratio i	Motor power P_{1M} [kW]	Output torque M_{2M} [Nm]	Service factor f.s.	Nominal power P_{1R} [kW]	Nominal torque M_{2R} [Nm]	Available B5 motor flanges		B14 motor flanges				Output Shaft	Ratios code			
							-G	132	-	-	-	-			-	-	-
507	2.76	9	166	1.6	14.4	265			not available				2980	standard ø35 ø40 On request	01		
395	3.54	9	213	1.3	11.6	275										2485	02
277	5.06	9	304	1.0	8.6	290										1891	03
241	5.81	7.5	281	1.2	8.5	330										1693	04
206	6.79	7.5	329	1.2	8.4	380										1495	05

The dynamic efficiency is **0.98** for all ratios

A) Motor Flanges Available
Flange Motore Disponibili

B) Supplied with Reduction Bushing
Fornito con Bussola di Riduzione

B) Available on Request without reduction bushing
Disponibile a Richiesta senza Bussola di Riduzione

C) Motor Flange Holes Position
Posizione Fori Flangia Motore

EN Unit **FC61** is supplied with synthetic oil for lifetime lubrication, no maintenance is necessary. See table 1 for lubrication and recommended quantity. In table 2 please see possible radial loads and axial loads on the gearbox.

I Il riduttore **FC61** viene fornito completo di olio sintetico per la lubrificazione permanente e non necessita di alcuna manutenzione. Vedi tab.1 per oli e quantità consigliati. In tab.2 sono presenti i carichi radiali e assiali applicabili al riduttore.

D Das Getriebe **FC61** ist mit synthetischem Öl gefüllt und ist lebensdauergeschmiert. In Tabelle 1 ist die Schmiermenge und das empfohlene Schmiermittel angegeben. In Tabelle 2 sind die zulässigen Radial - und Axialbelastungen des Getriebes aufgeführt.

F Le réducteur **FC61** est fourni complet avec de l'huile synthétique pour la lubrification permanente et ne nécessite aucun entretien. Voir tableau 1 concernant les huiles et les quantités conseillées. Les charges radiales et axiales applicables au réducteur sont précisées dans le tableau 2.

E El reductor tamaño **FC61** se suministra, lubricado de por vida con aceite sintético y no requieren mantenimiento alguna. Ver tabla 1, para cantidades y aceites recomendados. En la tabla 2, se encuentran las cargas radiales y axiales admitidas por el reductor.

Standard supplied	For these mounting position specify in the order or add oil Per queste posizioni specificare in fase d'ordine o aggiungere olio				
H1	H4	H3	H2	H5	H6
2.05 LT	1.25 LT	1.25 LT	1.40 LT	2.05 LT	1.40 LT
SHELL Omala S4 WE 320			ENI Telium VSF 320		

For all details on lubrication and plugs check our website **tab. 1**
Per maggiori dettagli su lubrificazione e tappi olio vedi il nostro sito web

RADIAL AND AXIAL LOADS

Output shaft
Albero di uscita

$F_{eq} = F_R \cdot \frac{149.5}{X+119.5}$

n_2	FA	FR	n_2	FA	FR	n_2	FA	FR
300	600	3000	140	720	3600	70	940	4700
250	640	3200	120	740	3700	40	1220	6100
200	690	3460	85	860	4300	15	1300	6500

On request reinforced bearings to increase loads.
A richiesta cuscinetti rinforzati per aumentare i carichi.

tab. 2

PFC61C... Basic gearbox
Riduttore base

Gearbox weight
peso riduttore **31.0 kg**

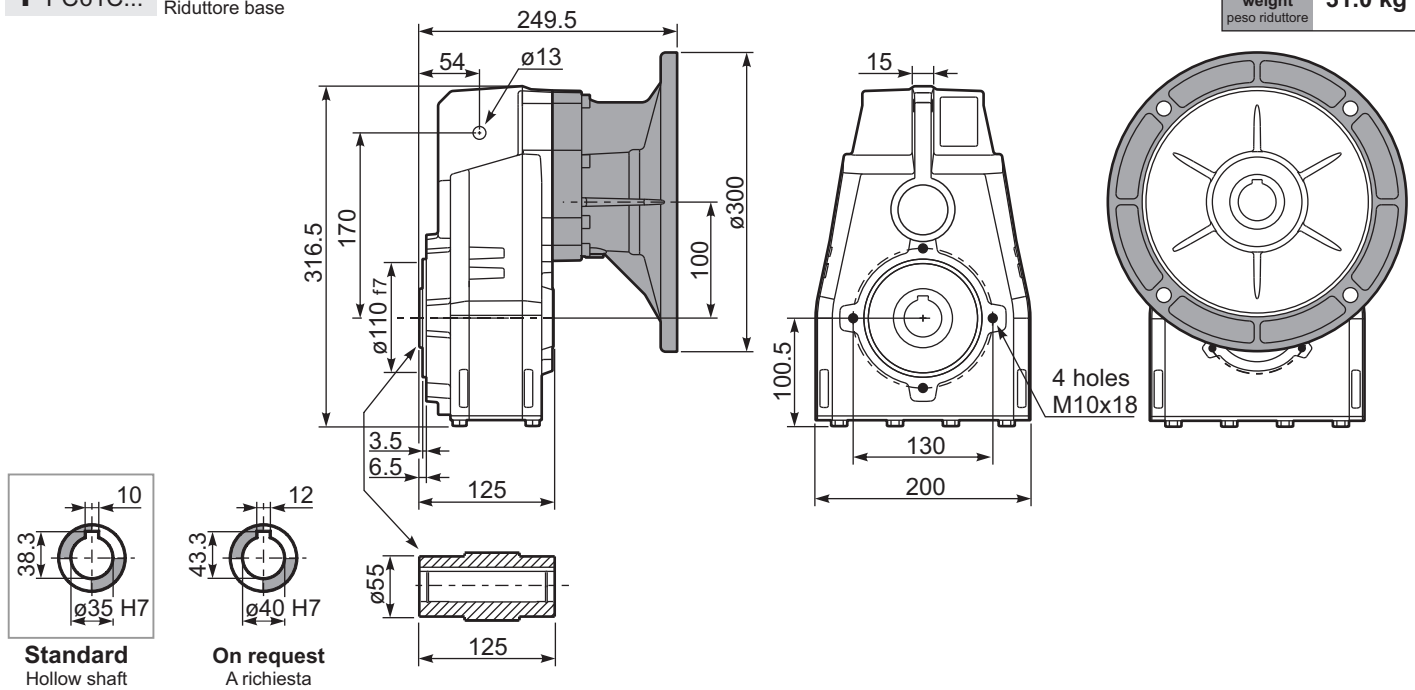

PFC61...-F... Output flange
Flangia uscita

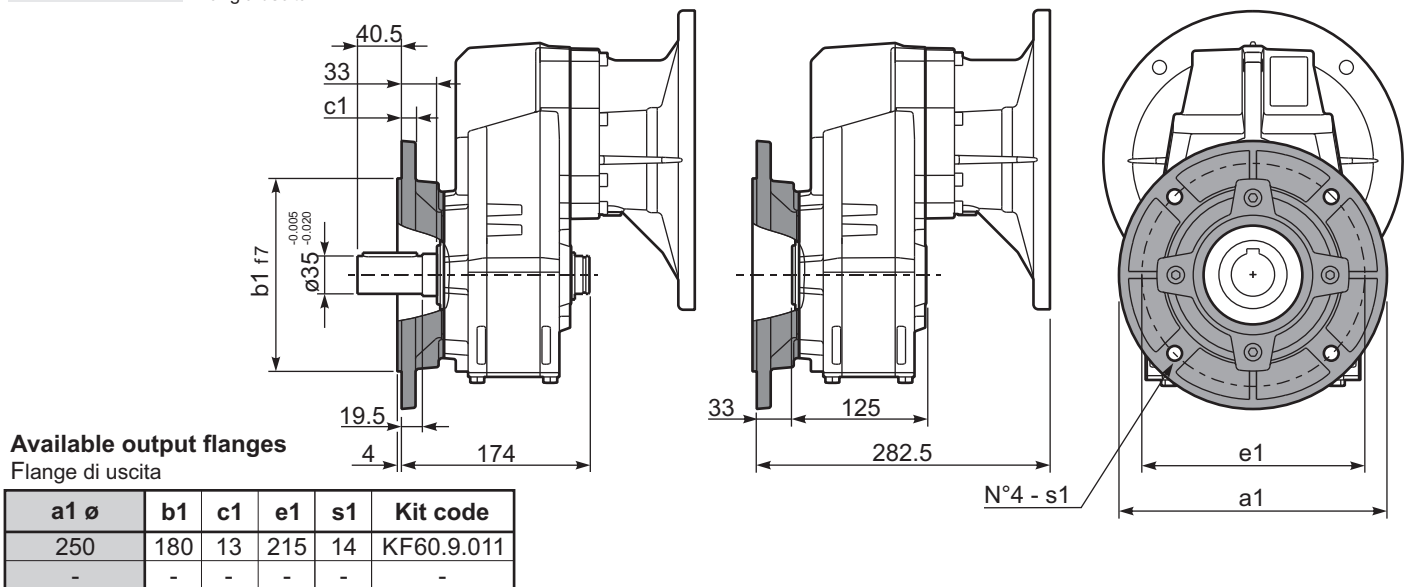

PFC61 A... Single output shaft
Albero uscita semplice

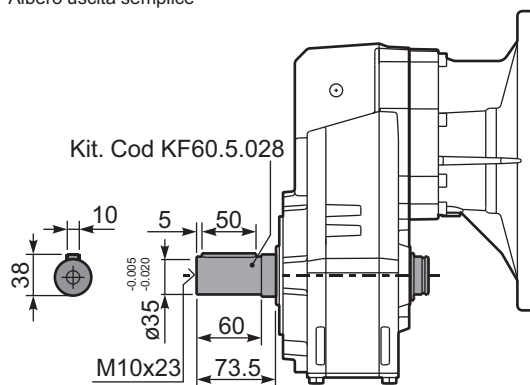



QUICK SELECTION / Selezione veloce

input speed (n_1) = 1400 min⁻¹

Output Speed n_2 [min ⁻¹]	Ratio i	Motor power P_{1M} [kW]	Output torque M_{2M} [Nm]	Service factor f.s.	Nominal power P_{1R} [kW]	Nominal torque M_{2R} [Nm]	Available B5 motor flanges					Available B14 motor flanges				Output Shaft 	Ratios code 	
							-C	-D	-E	-F	-G	-R	-T	-U	-V			
							71	80	90	100	112	80	90	100	112			132
213	6.57	7.5	312	1.2	8.8	380	B										3018	01
185	7.56	7.5	358	1.1	7.9	390	B										3016	02
159	8.82	7.5	419	1.0	7.1	410	B										3014	03
113	12.39	7.5	588	1.0	7.2	580	B										2018	04
98	14.24	5.5	499	1.2	6.4	600	B										2016	05
84	16.75	5.5	587	1.1	6.1	665	B										1618	06
73	19.25	5.5	675	1.0	5.4	675	B										1616	07
64	21.78	4	558	1.2	4.7	675	B										1318	08
56	25.04	4	642	1.1	4.1	675	B										1316	09
47.9	29.23	4	750	0.9	3.5	675	B										1314	10
45.7	30.65	3	592	1.1	3.4	675	B										1116	11
39.1	35.78	3	691	1.0	2.9	675	B										1114	12
36.3	38.55	2.2	548	1.1	2.3	580	B										818	13
31.6	44.32	2.2	630	1.1	2.3	665	B										816	14
27.1	51.74	2.2	735	0.9	2.0	675	B										814	15
22.9	61.03	1.1	437	1.1	1.2	480	B										616	16
19.6	71.25	1.1	510	1.1	1.2	560	B										614	17

The dynamic efficiency is **0.96** for all ratios

- Motor Flanges Available
Flange Motore Disponibili
- Supplied with Reduction Bushing
Fornito con Bussola di Riduzione
- Available on Request without reduction bushing
Disponibile a Richiesta senza Bussola di Riduzione
- Motor Flange Holes Position
Posizione Fori Flangia Motore

EN Unit **FC62** is supplied with synthetic oil for lifetime lubrication, no maintenance is necessary. See table 1 for lubrication and recommended quantity. In table 2 please see possible radial loads and axial loads on the gearbox.

I Il riduttore **FC62** viene fornito completo di olio sintetico per la lubrificazione permanente e non necessita di alcuna manutenzione. Vedi tab.1 per oli e quantità consigliati. In tab.2 sono presenti i carichi radiali e assiali applicabili al riduttore.

D Das Getriebe **FC62** ist mit synthetischem Öl gefüllt und ist lebensdauergeschmiert. In Tabelle 1 ist die Schmiermenge und das empfohlene Schmiermittel angegeben. In Tabelle 2 sind die zulässigen Radial - und Axialbelastungen des Getriebes aufgeführt.

F Le réducteur **FC62** est fourni complet avec de l'huile synthétique pour la lubrification permanente et ne nécessite aucun entretien. Voir tableau 1 concernant les huiles et les quantités conseillées. Les charges radiales et axiales applicables au réducteur sont précisées dans le tableau 2.

E El reductor tamaño **FC62** se suministra, lubricado de por vida con aceite sintético y no requieren mantenimiento alguna. Ver tabla 1, para cantidades y aceites recomendados. En la tabla 2, se encuentran las cargas radiales y axiales admitidas por el reductor.

Standard supplied	For these mounting position specify in the order or add oil Per queste posizioni specificare in fase d'ordine o aggiungere olio				
2.05 LT	1.25 LT	1.25 LT	1.40 LT	2.20 LT	1.40 LT
SHELL Omala S4 WE 320			ENI Telium VSF 320		

For all details on lubrication and plugs check our website **tab. 1**
Per maggiori dettagli su lubrificazione e tappi olio vedi il nostro sito web

RADIAL AND AXIAL LOADS

Output shaft
Albero di uscita

$F_{eq} = FR \cdot \frac{149.5}{X+119.5}$

n_2	FA	FR	n_2	FA	FR	n_2	FA	FR
300	600	3000	140	720	3600	70	940	4700
250	640	3200	120	740	3700	40	1220	6100
200	690	3460	85	860	4300	15	1300	6500

On request reinforced bearings to increase loads.
A richiesta cuscinetti rinforzati per aumentare i carichi.

Input shaft
Albero in entrata

n_1	FA	FR
1400	450	2250
900	500	2500
500	600	3000

tab. 2

PFC62C... Basic gearbox
Riduttore base

Gearbox weight
peso riduttore **20.8 kg**

M. flanges	Kit code	øF	A
71B5	K023.4.041	160	227
80/90B5	K023.4.042	200	229
100/112B5	K023.4.043	250	238
132B5	KC51.4.043	300	259
80B14	K085.4.046	120	229
90B14	K085.4.045	140	229
100/112B14	K085.4.047	160	238
132B14	KC51.4.041	200	259

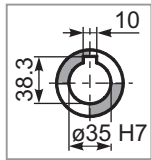
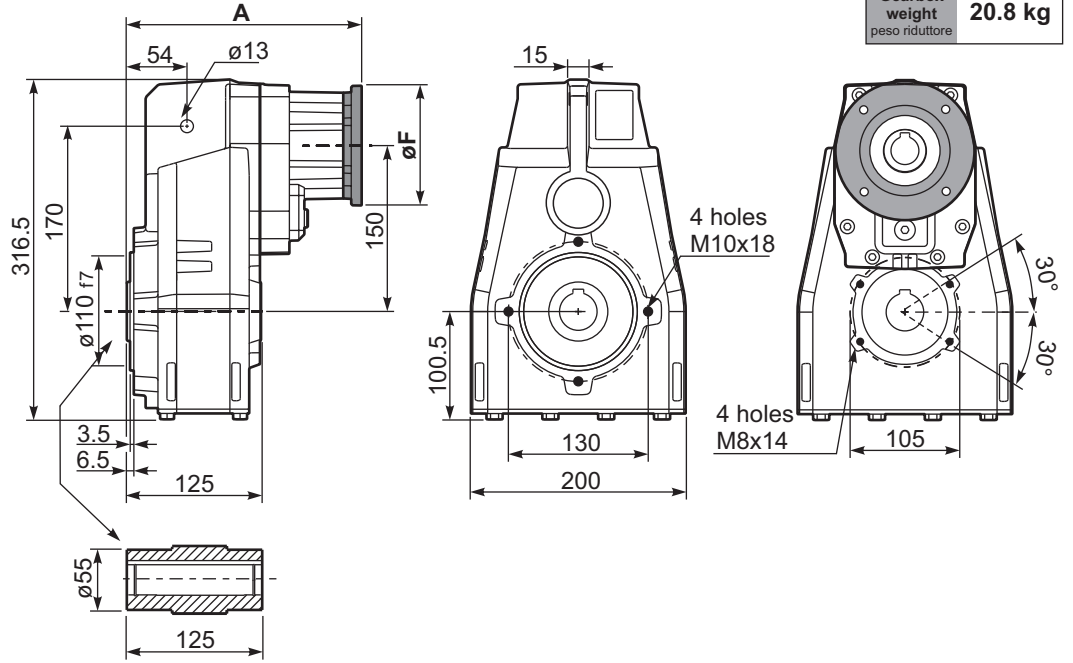

Standard
Hollow shaft

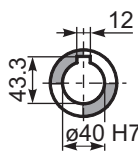

On request
A richiesta

PFC62...-F... Output flange
Flangia uscita

M. flanges	k1
71B5	260
80/90B5	262
100/112B5	271
132B5	289
80B14	262
90B14	262
100/112B14	271
132B14	289

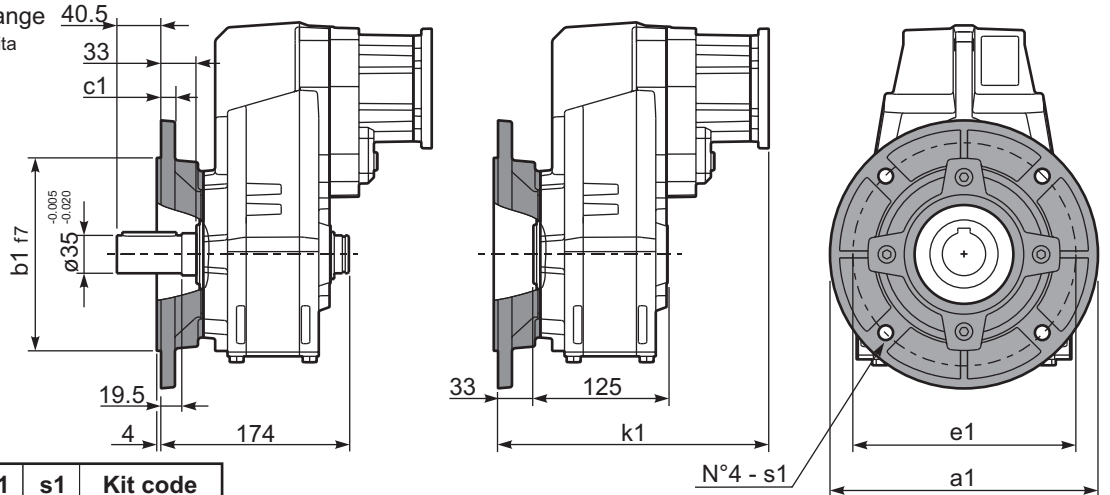

Available output flanges
Flange di uscita

a1 ø	b1	c1	e1	s1	Kit code
250	180	13	215	14	KF60.9.011
-	-	-	-	-	-

RFC62C... Input Shaft
Albero in entrata

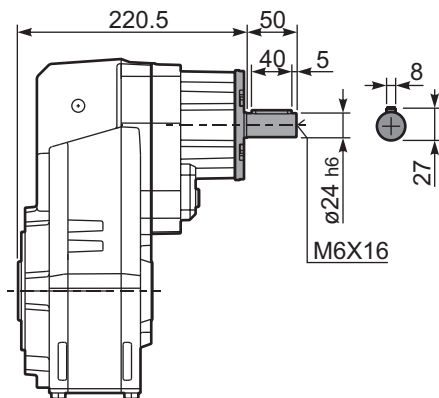

PFC62 A... Single output shaft
Albero uscita semplice

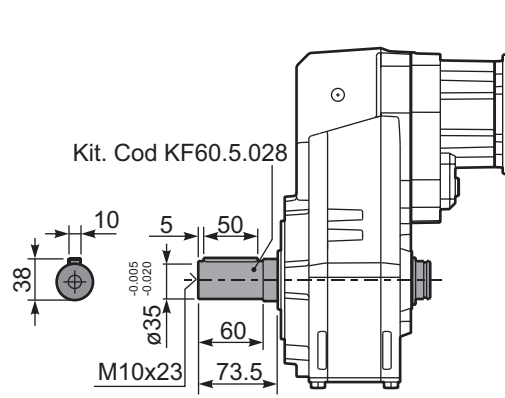

PFC62D... Shrink disk
Calettatore

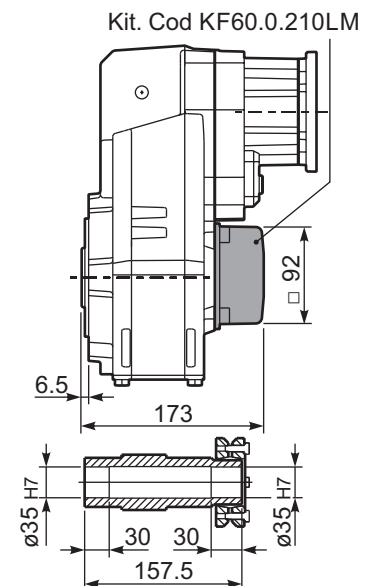



QUICK SELECTION / Selezione veloce

input speed (n_1) = 1400 min⁻¹

Output Speed n_2 [min ⁻¹]	Ratio i	Motor power P_{1M} [kW]	Output torque M_{2M} [Nm]	Service factor f.s.	Nominal power P_{1R} [kW]	Nominal torque M_{2R} [Nm]	Available B5 motor flanges				Available B14 motor flanges			Output Shaft 	Ratios code
							-B	-C	-D	-E	-Q	-R	-T		
							63	71	80	90	71	80	90		
22.6	61.89	1.5	594	1.1	1.7	675	B				C	C		191318	01
19.7	71.16	1.5	683	1.0	1.5	675	B				C	C		191316	02
17.0	82.48	1.5	792	0.9	1.3	675	B				C	C		171316	03
14.5	96.29	1.1	675	1.0	1.1	675	B				C	C		171314	04
13.9	100.51	1.1	705	1.0	1.0	675	B				C	C		131318	05
12.1	115.56	0.75	556	1.2	0.91	675	B				C	C		131316	06
11.1	125.96	0.75	606	1.1	0.82	665	B				C	C		190816	07
10.4	134.91	0.75	649	1.0	0.78	675	B				C	C		131314	08
9.5	147.05	0.75	707	1.0	0.72	675	B				C	C		190814	09
8.2	170.44	0.55	605	1.1	0.62	675	B				C	C		170814	10
7.6	184.15	0.55	653	1.0	0.57	675	B				C	C		101314	11
6.8	205.87	0.55	730	0.9	0.51	675	B				C	C		91316	12
5.8	240.34	0.37	570	1.2	0.44	675	B				C	C		91314	13
5.0	279.22	0.37	662	1.0	0.37	665	B				C	C		100816	14
4.3	325.97	0.37	773	0.9	0.32	675	B				C	C		100814	15
3.8	364.41	0.25	583	1.1	0.28	665	B				C	C		90816	16
3.3	425.43	0.25	681	1.0	0.25	675	B				C	C		90814	17
2.9	481.19	0.18	589	1.1	0.22	665	B				C	C		70816	18
2.5	561.76	0.18	687	1.0	0.19	675	B				C	C		70814	19

The dynamic efficiency is **0.94** for all ratios

- Motor Flanges Available Flange Motore Disponibili
- Supplied with Reduction Bushing Fornito con Bussola di Riduzione
- Available on Request without reduction bushing Disponibile a Richiesta senza Bussola di Riduzione
- Motor Flange Holes Position Posizione Fori Flangia Motore

EN Unit FC63 is supplied with synthetic oil for lifetime lubrication, no maintenance is necessary. See table 1 for lubrication and recommended quantity. In table 2 please see possible radial loads and axial loads on the gearbox.

I Il riduttore FC63 viene fornito completo di olio sintetico per la lubrificazione permanente e non necessita di alcuna manutenzione. Vedi tab.1 per oli e quantità consigliati. In tab.2 sono presenti i carichi radiali e assiali applicabili al riduttore.

D Das Getriebe FC63 ist mit synthetischem Öl gefüllt und ist lebensdauergeschmiert. In Tabelle 1 ist die Schmiermenge und das empfohlene Schmiermittel angegeben. In Tabelle 2 sind die zulässigen Radial - und Axialbelastungen des Getriebes aufgeführt.

F Le réducteur FC63 est fourni complet avec de l'huile synthétique pour la lubrification permanente et ne nécessite aucun entretien. Voir tableau 1 concernant les huiles et les quantités conseillées. Les charges radiales et axiales applicables au réducteur sont précisées dans le tableau 2.

E El reductor tamaño FC63 se suministra, lubricado de por vida con aceite sintético y no requieren mantenimiento alguna. Ver tabla 1, para cantidades y aceites recomendados. En la tabla 2, se encuentran las cargas radiales y axiales admitidas por el reductor.

Standard supplied	For these mounting position specify in the order or add oil				
	Per queste posizioni specificare in fase d'ordine o aggiungere olio				
H1	H4	H3	H2	H5	H6
2.30 LT	1.35 LT	1.35 LT	1.55 LT	2.45 LT	1.55 LT
SHELL Omala S4 WE 320			ENI Telium VSF 320		

For all details on lubrication and plugs check our website **tab. 1**
Per maggiori dettagli su lubrificazione e tappi olio vedi il nostro sito web

RADIAL AND AXIAL LOADS

Output shaft
Albero di uscita

$F_{eq} = F_R \cdot \frac{149.5}{X+119.5}$

On request reinforced bearings to increase loads.
A richiesta cuscinetti rinforzati per aumentare i carichi.

Input shaft
Albero in entrata

n_2	FA	FR	n_2	FA	FR	n_2	FA	FR
300	600	3000	140	720	3600	70	940	4700
250	640	3200	120	740	3700	40	1220	6100
200	690	3460	85	860	4300	15	1300	6500

n_1	FA	FR
1400	240	1200
900	280	1400
500	340	1700

tab. 2

PFC63C... Basic gearbox
Riduttore base

Gearbox weight
peso riduttore **20.8 kg**

M. flanges	Kit code	øF	A
63B5	K063.4.041	140	239
71B5	K063.4.042	160	237
80/90B5	K063.4.043	200	239
71B14	K063.4.047	105	237
80B14	K063.4.046	120	239
90B14	K063.4.041	140	239

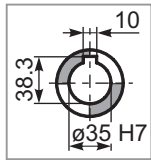
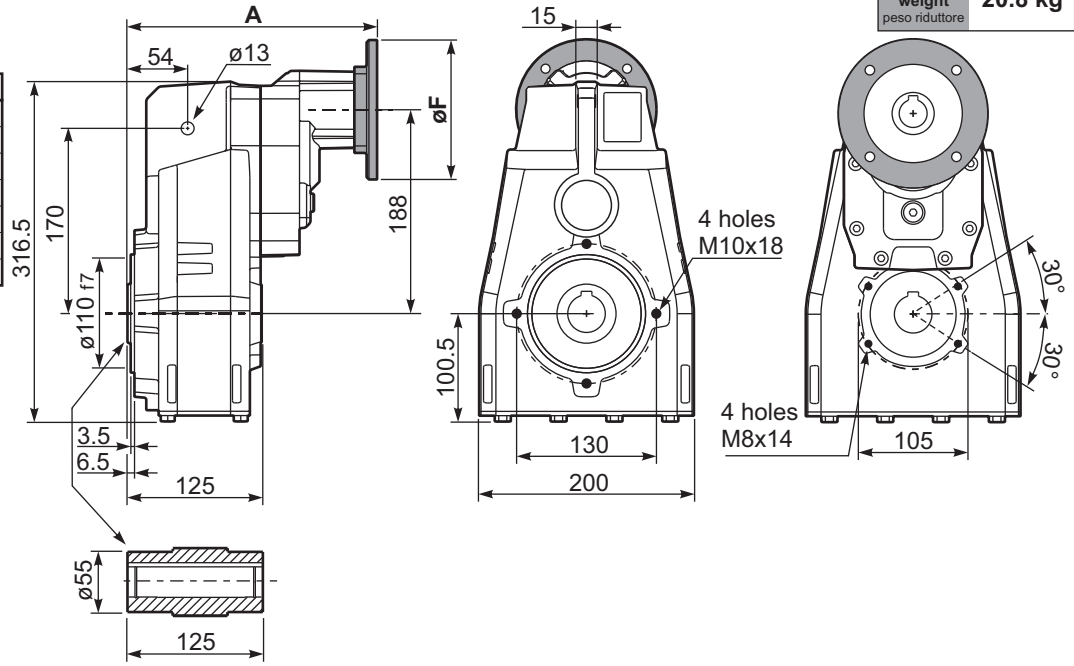

Standard
Hollow shaft

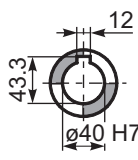

On request
A richiesta

PFC63...-F... Output flange
Flangia uscita

Motor Flange	k1
63B5	272
71B5	270
80/90B5	272
71B14	270
80B14	272
90B14	272

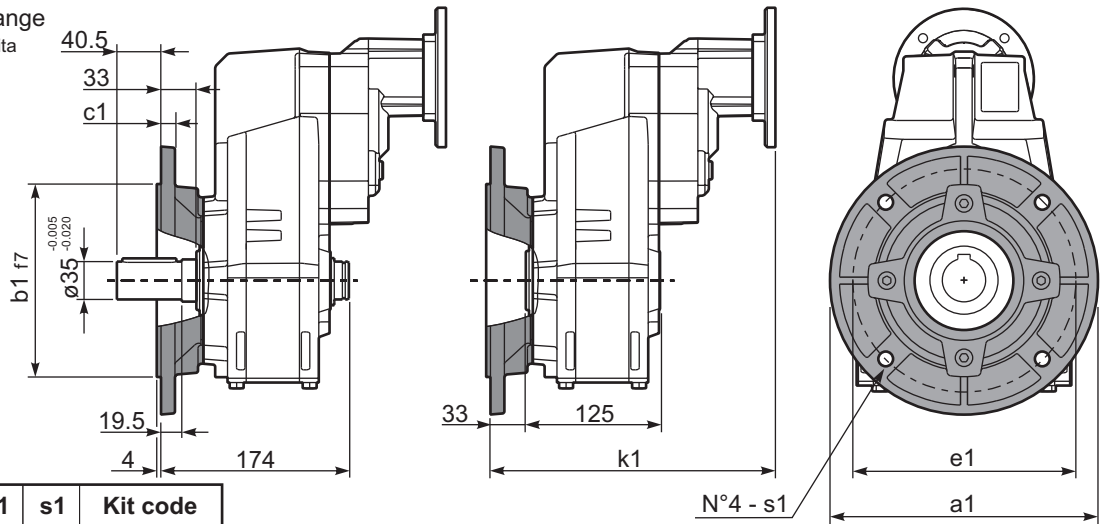

Available output flanges
Flange di uscita

a1 ø	b1	c1	e1	s1	Kit code
250	180	13	215	14	KF60.9.011
-	-	-	-	-	-

RFC63C... Input Shaft
Albero in entrata

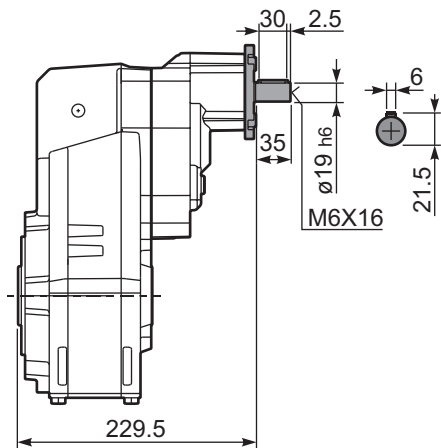

PFC63 A... Single output shaft
Albero uscita semplice

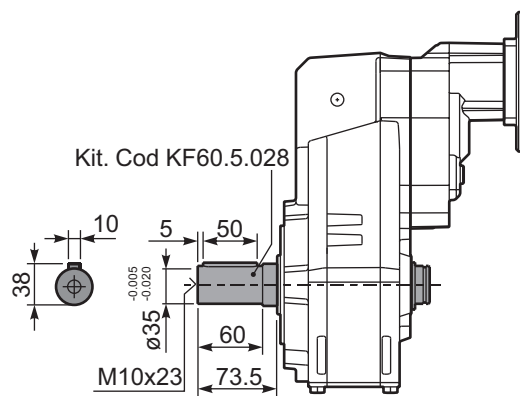

PFC63D... Shrink disk
Calettatore

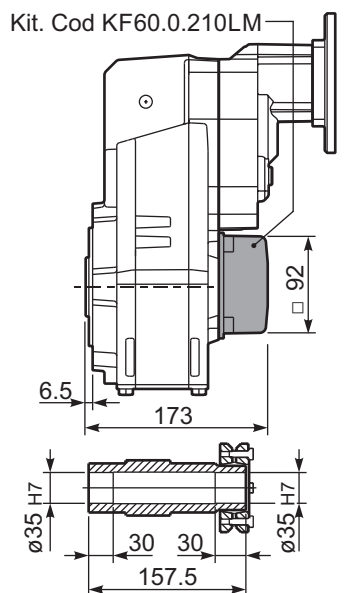



QUICK SELECTION / Selezione veloce

input speed (n_1) = 1400 min⁻¹

Output Speed n_2 [min ⁻¹]	Ratio i	Motor power P_{1M} [kW]	Output torque M_{2M} [Nm]	Service factor f.s.	Nominal power P_{1R} [kW]	Nominal torque M_{2R} [Nm]	Available B5 motor flanges		B14 motor flanges				Output Shaft 	Ratios code 	
							-G	132	-	-	-	-			-
227	6.17	9	371	1.2	10.9	450			not available				18111	standard ø40 ø45 On request	01
198	7.06	9	425	1.4	12.7	600							16113		02
170	8.21	9	494	1.4	12.2	670							14115		03

The dynamic efficiency is **0.98** for all ratios

A Motor Flanges Available
Flange Motore Disponibili

B Supplied with Reduction Bushing
Fornito con Bussola di Riduzione

B Available on Request without reduction bushing
Disponibile a Richiesta senza Bussola di Riduzione

C Motor Flange Holes Position
Posizione Fori Flangia Motore

EN Unit **FC71** is supplied without lubricant and equipped with a breather, level and drain plugs. User can add mineral oil keeping existing plugs. Should the user wish to fill it with synthetic oil, it is recommended to replace the existing plugs with a closed plug.
See table 1 for lubrication and recommended quantity.
In table 2 please see possible radial loads and axial loads on the gearbox.

I Il riduttore tipo **FC71** è fornito privo di lubrificazione con tappi di sfiato, livello e scarico olio. L'utente può immettere olio minerale mantenendo i tappi esistenti. Se immetterà olio sintetico, dovrà sostituire i tappi esistenti con altri tipo chiuso.
Tab.1 per oli e quantità consigliati.
Tab.2 carichi radiali e assiali applicabili al riduttore.

D Das Getriebe der Baugröße **FC71** wird ohne Schmiermittel geliefert. Es ist jedoch mit Einfüllschraube, Überdruckventil und Ablassschraube ausgerüstet. Das benötigte mineralische Öl kann über die Einfüllschraube eingefüllt werden. Sollte synthetisches Öl bevorzugt werden, so ist sind das eingebaute Überdruckventil durch eine geschlossenen Schraube zu ersetzen.
In Tabelle 1 ist die Schmiermenge und das empfohlene Schmiermittel angegeben
In Tabelle 2 sind die zulässigen Radial - und Axialbelastungen des Getriebes aufgeführt.

F Le réducteur de type **FC71** est fourni sans lubrification et avec un bouchon de remplissage, de niveau et d'évacuation de l'huile. L'utilisateur peut y verser de l'huile minérale en conservant les bouchons existants. S'il y versera de l'huile synthétique, il devra substituer les bouchons existants avec d'autres bouchons de type fermé.
Voir tableau 1 concernant les huiles et les quantités conseillées.
Voir tableau 2 concernant les charges radiales et axiales applicables au réducteur

E El reductor tamaño **FC71** se suministra sin lubricante, provisto de tapones de respiración, nivel y descarga de aceite. El usuario puede utilizar aceite mineral, manteniendo los tapones existentes. Si prefiere utilizar aceite sintético deberá sustituir los tapones existentes por tapones ciegos. La prerreducción se suministra con tapones ciegos, lubricado de por vida con aceite sintético. Ver tabla 1, para cantidades y aceites recomendados. En la tabla 2, se encuentran las cargas radiales y axiales admitidas por el reductor.

H1	H4	H3	H2	H5	H6
3.30 LT	1.90 LT	1.90 LT	1.80 LT	3.30 LT	1.90 LT
SHELL Omala S2 GX 460			ENI Blasia 460		

For all details on lubrication and plugs check our website **tab. 1**
Per maggiori dettagli su lubrificazione e tappi olio vedi il nostro sito web

RADIAL AND AXIAL LOADS

Output shaft
Albero di uscita

$$F_{eq} = FR \cdot \frac{174.5}{X+134.5}$$

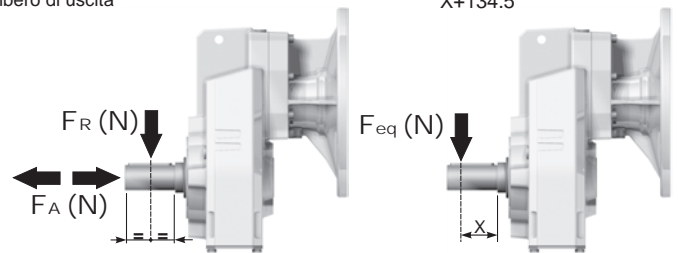

n_2	FA	FR	n_2	FA	FR	n_2	FA	FR
300	740	3700	140	860	4300	70	1020	5100
250	800	4000	120	900	4500	40	1300	6500
200	830	4150	85	970	4850	15	1700	8500

On request reinforced bearings to increase loads.

A richiesta cuscinetti rinforzati per aumentare i carichi.

tab. 2

PFC71C... Basic gearbox
Riduttore base

Gearbox weight
peso riduttore **35.0 kg**

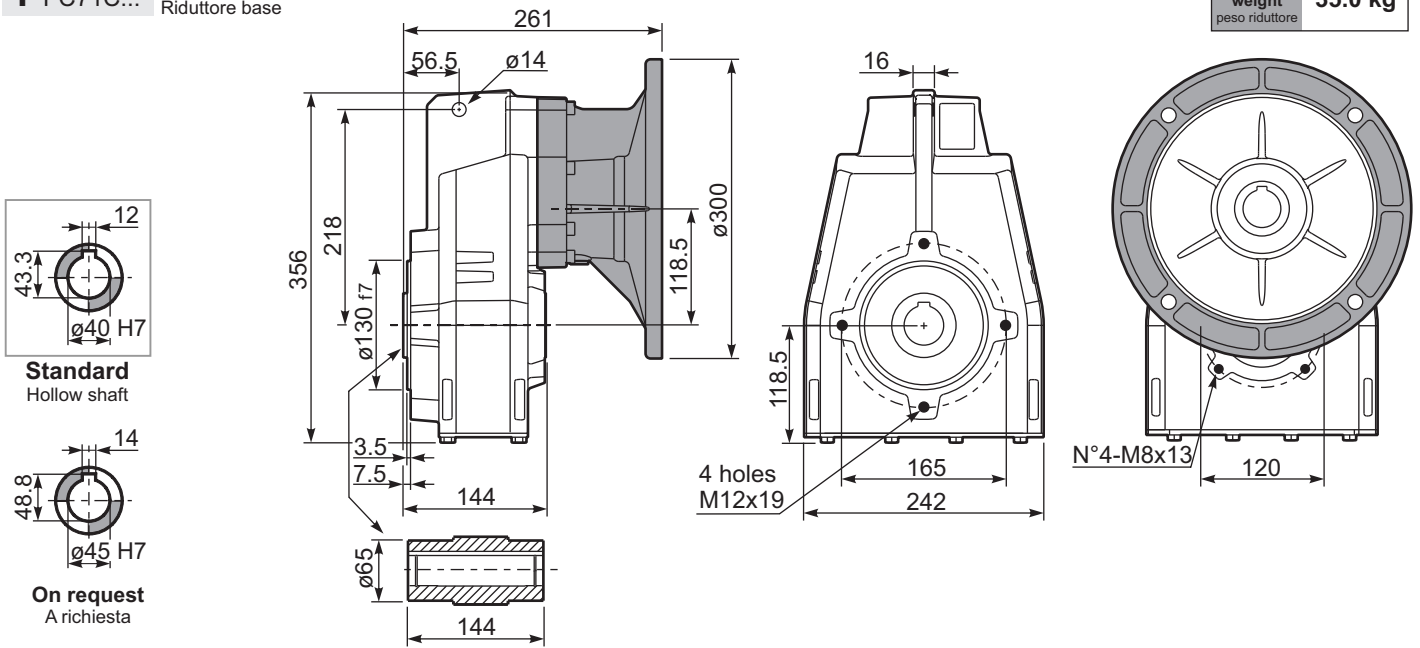

PFC71...-F... Output flange
Flangia uscita

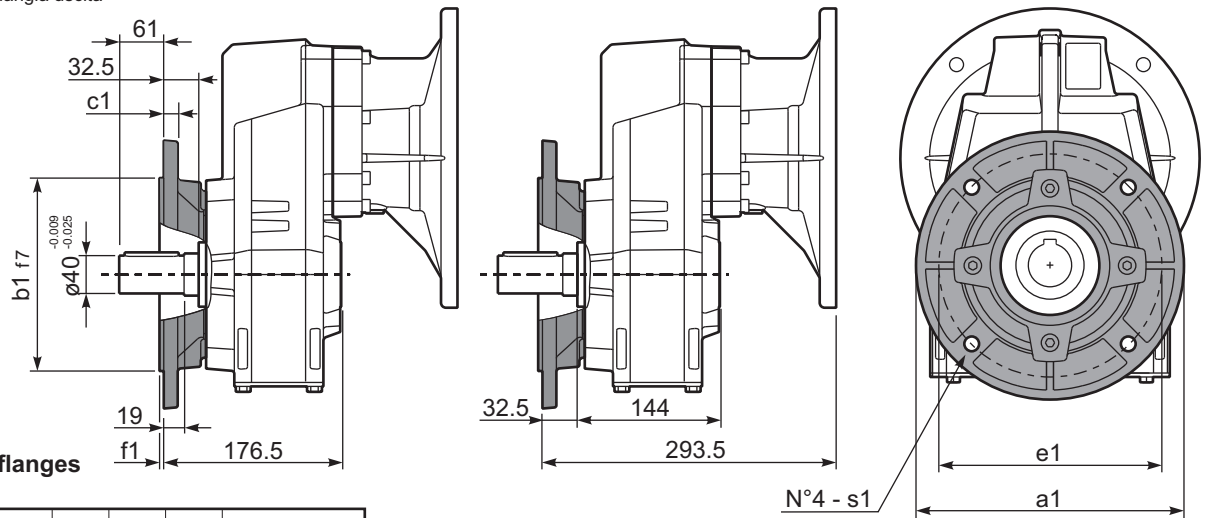

a1 \varnothing	b1	c1	e1	f1	s1	Kit code
250	180	13	215	3	14	KF70.9.011
300	230	16	265	4	14	KF70.9.012

PFC71 A... Single output shaft
Albero uscita semplice

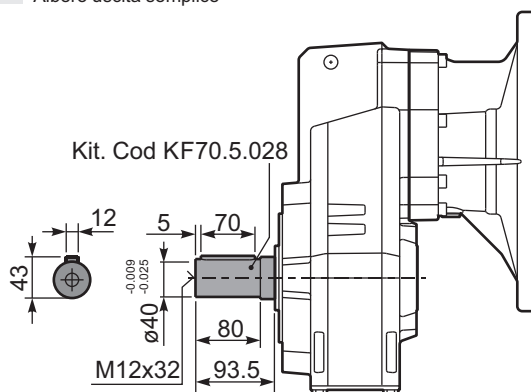



QUICK SELECTION / Selezione veloce

input speed (n_1) = 1400 min⁻¹

Output Speed n_2 [min ⁻¹]	Ratio i	Motor power P_{1M} [kW]	Output torque M_{2M} [Nm]	Service factor f.s.	Nominal power P_{1R} [kW]	Nominal torque M_{2R} [Nm]	Available B5 motor flanges					Available B14 motor flanges				Output Shaft 	Ratios code
							-C	-D	-E	-F	-G	-R	-T	-U	-V		
							71	80	90	100	112	80	90	100	112		
175	8.02	9	473	1.1	9.9	520	B									3018	01
152	9.18	9	541	1.1	9.8	590	B									3016	02
131	10.68	9	630	1.1	9.7	680	B									3014	03
93	15.11	7.5	717	1.1	7.8	775	B									2018	04
81	17.30	7.5	821	1.1	7.8	885	B									2016	05
70	20.13	7.5	955	0.9	6.8	900	B									2014	06
60	23.39	5.5	820	1.1	5.9	900	B									1616	07
51	27.21	5.5	954	0.9	5.1	900	B									1614	08
46.0	30.42	4	780	1.2	4.5	900	B									1316	09
39.6	35.38	4	907	1.0	3.9	900	B									1314	10
37.6	37.24	3	719	1.2	3.7	895	B									1116	11
32.3	43.31	3	836	1.1	3.2	900	B									1114	12
29.8	47.02	2.2	668	1.1	2.3	705	B									818	13
26.0	53.85	2.2	765	1.1	2.3	810	B									816	14
22.4	62.63	2.2	890	1.0	2.2	900	B									814	15
18.9	74.16	1.1	531	1.1	1.2	585	B									616	16
16.2	86.25	1.1	617	1.1	1.2	680	B									614	17

The dynamic efficiency is **0.96** for all ratios

Motor Flanges Available
Flange Motore Disponibili

B) Supplied with Reduction Bushing
Fornito con Bussola di Riduzione

B) Available on Request without reduction bushing
Disponibile a Richiesta senza Bussola di Riduzione

C) Motor Flange Holes Position
Posizione Fori Flangia Motore

EN Unit **FC72** is supplied without lubricant and equipped with a breather, level and drain plugs. User can add mineral oil keeping existing plugs. Should the user wish to fill it with synthetic oil, it is recommended to replace the existing plugs with a closed plug. See table 1 for lubrication and recommended quantity. In table 2 please see possible radial loads and axial loads on the gearbox.

I Il riduttore tipo **FC72** è fornito privo di lubrificazione con tappi di sfiato, livello e scarico olio. L'utente può immettere olio minerale mantenendo i tappi esistenti. Se immetterà olio sintetico, dovrà sostituire i tappi esistenti con altri tipo chiuso. Tab.1 per oli e quantità consigliati. Tab.2 carichi radiali e assiali applicabili al riduttore.

D Das Getriebe der Baugröße **FC72** wird ohne Schmiermittel geliefert. Es ist jedoch mit Einfüllschraube, Überdruckventil und Ablassschraube ausgerüstet. Das benötigte mineralische Öl kann über die Einfüllschraube eingefüllt werden. Sollte synthetisches Öl bevorzugt werden, so ist sind das eingebaute Überdruckventil durch eine geschlossenen Schraube zu ersetzen. In Tabelle 1 ist die Schmiermenge und das empfohlene Schmiermittel angegeben. In Tabelle 2 sind die zulässigen Radial - und Axialbelastungen des Getriebes aufgeführt.

F Le réducteur de type **FC72** est fourni sans lubrification et avec un bouchon de remplissage, de niveau et d'évacuation de l'huile. L'utilisateur peut verser de l'huile minérale en conservant les bouchons existants. S'il y versera de l'huile synthétique, il devra substituer les bouchons existants avec d'autres bouchons de type fermé. Voir tableau 1 concernant les huiles et les quantités conseillées. Voir tableau 2 concernant les charges radiales et axiales applicables au réducteur.

E El reductor tamaño **FC72** se suministra sin lubricante, provisto de tapones de respiración, nivel y descarga de aceite. El usuario puede utilizar aceite mineral, manteniendo los tapones existentes. Si prefiere utilizar aceite sintético deberá sustituir los tapones existentes por tapones ciegos. La prerreducción se suministra con tapones ciegos, lubricado de por vida con aceite sintético. Ver tabla 1, para cantidades y aceites recomendados. En la tabla 2, se encuentran las cargas radiales y axiales admitidas por el reductor.

H1	H4	H3	H2	H5	H6
3.50 LT	1.90 LT	1.90 LT	1.80 LT	3.60 LT	1.90 LT
SHELL Omala S2 GX 460			ENI Blasia 460		

For all details on lubrication and plugs check our website **tab. 1**
Per maggiori dettagli su lubrificazione e tappi olio vedi il nostro sito web

RADIAL AND AXIAL LOADS

Output shaft
Albero di uscita

$F_{eq} = F_R \cdot \frac{174.5}{X+134.5}$

n_2	FA	FR	n_2	FA	FR	n_2	FA	FR
300	740	3700	140	860	4300	70	1020	5100
250	800	4000	120	900	4500	40	1300	6500
200	830	4150	85	970	4850	15	1700	8500

On request reinforced bearings to increase loads.
A richiesta cuscinetti rinforzati per aumentare i carichi.

Input shaft
Albero in entrata

n_1	FA	FR
1400	450	2250
900	500	2500
500	600	3000

tab. 2

PFC72C... Basic gearbox
Riduttore base

M. flanges	Kit code	øF	A
71B5	K023.4.041	160	238.5
80/90B5	K023.4.042	200	240.5
100/112B5	K023.4.043	250	249.5
132B5	KC51.4.043	300	270.5
80B14	K085.4.046	120	240.5
90B14	K085.4.045	140	240.5
100/112B14	K085.4.047	160	249.5
132B14	KC51.4.041	200	270.5

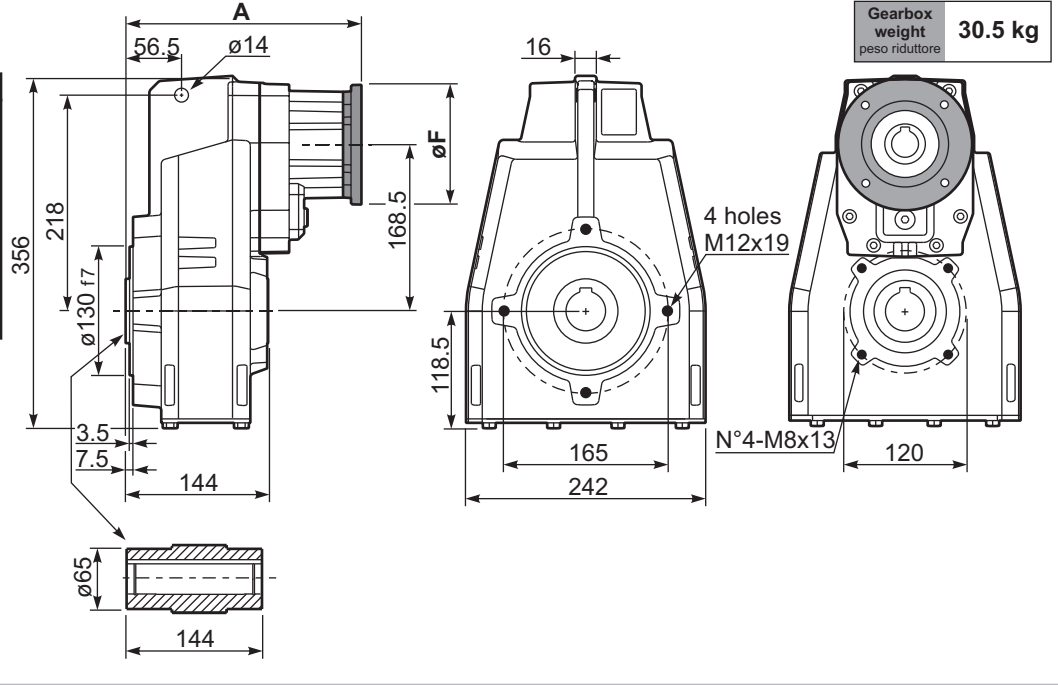

Gearbox weight
peso riduttore **30.5 kg**

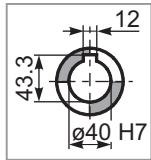

Standard
Hollow shaft

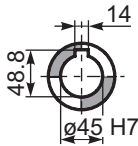

On request
A richiesta

PFC72...-F... Output flange
Flangia uscita

M. flanges	k1
71B5	271
80/90B5	273
100/112B5	282
132B5	300
80B14	273
90B14	273
100/112B14	282
132B14	300

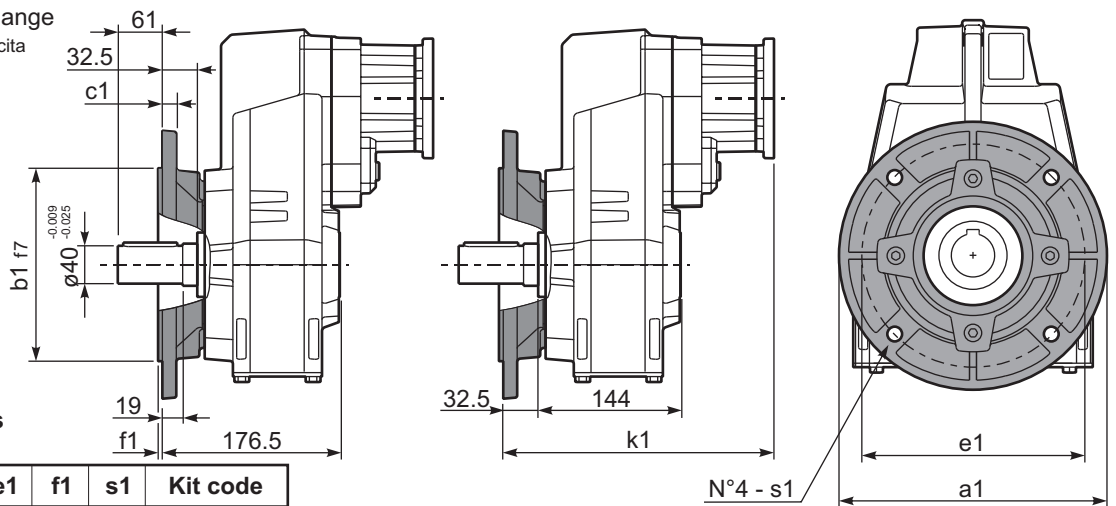

Available output flanges
Flange di uscita

a1 ø	b1	c1	e1	f1	s1	Kit code
250	180	13	215	3	14	KF70.9.011
300	230	16	265	4	14	KF70.9.012

RFC72C... Input Shaft
Albero in entrata

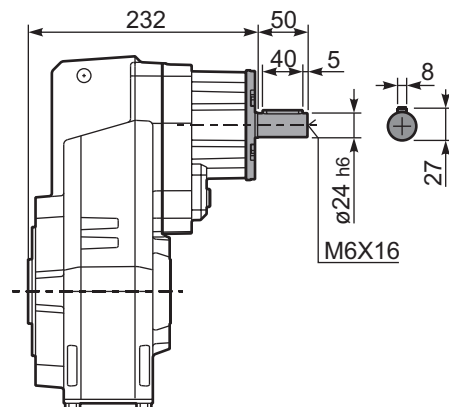

PFC72 A... Single output shaft
Albero uscita semplice

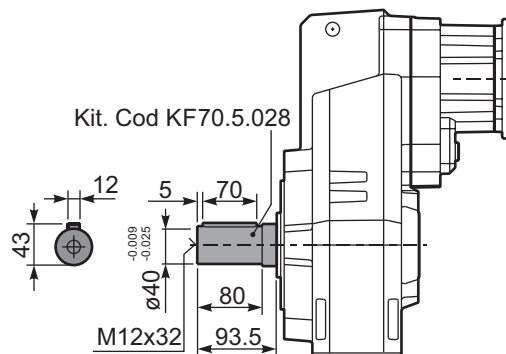

PFC72D... Shrink disk
Calettatore

Kit. Cod KF70.0.210LM

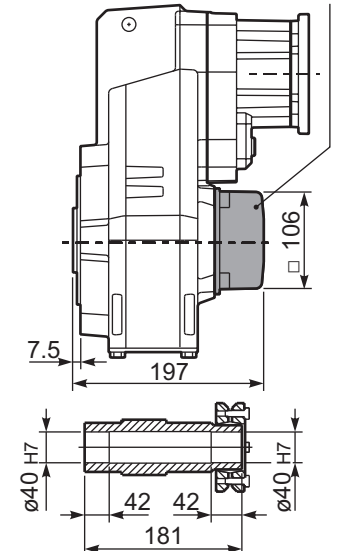



QUICK SELECTION / Selezione veloce

input speed (n_1) = 1400 min⁻¹

Output Speed n_2 [min ⁻¹]	Ratio i	Motor power P_{1M} [kW]	Output torque M_{2M} [Nm]	Service factor f.s.	Nominal power P_{1R} [kW]	Nominal torque M_{2R} [Nm]	Available B5 motor flanges				Available B14 motor flanges			Output Shaft 	Ratios code
							-B	-C	-D	-E	-Q	-R	-T		
							63	71	80	90	71	80	90		
18.5	75.50	1.5	725	1.1	1.7	825	B				C	C		191318	01
16.2	86.47	1.5	830	1.1	1.6	900	B				C	C		191316	02
14.0	100.22	1.5	962	0.9	1.4	900	B				C	C		171316	03
12.0	116.56	1.1	817	1.1	1.2	900	B				C	C		171314	04
10.2	136.82	1.1	959	0.9	1.0	900	B				C	C		151314	05
9.1	153.05	0.75	736	1.1	0.83	810	B				C	C		190816	06
8.6	163.31	0.75	785	1.1	0.86	900	B				C	C		131314	07
7.9	178.01	0.75	856	1.1	0.79	900	B				C	C		190814	08
7.3	191.67	0.75	922	1.0	0.73	900	B				C	C		101316	09
6.8	206.32	0.75	992	0.9	0.68	900	B				C	C		170814	10
6.3	222.92	0.55	791	1.1	0.63	900	B				C	C		101314	11
5.8	242.18	0.55	859	1.0	0.58	900	B				C	C		150814	12
5.6	250.15	0.55	888	1.0	0.56	900	B				C	C		91316	13
4.8	289.08	0.55	1026	0.9	0.49	900	B				C	C		130814	14
4.2	330.31	0.37	783	1.1	0.42	890	B				C	C		71316	15
3.5	394.59	0.37	936	1.0	0.36	900	B				C	C		100814	16
2.7	514.99	0.25	824	1.1	0.27	900	B				C	C		90814	17
2.1	680.03	0.18	832	1.1	0.21	900	B				C	C		70814	18

The dynamic efficiency is **0.94** for all ratios

Motor Flanges Available
Flange Motore Disponibili

B) Supplied with Reduction Bushing
Fornito con Bussola di Riduzione

B) Available on Request without reduction bushing
Disponibile a Richiesta senza Bussola di Riduzione

C) Motor Flange Holes Position
Posizione Fori Flangia Motore

EN Unit **FC73** is supplied without lubricant and equipped with a breather, level and drain plugs. User can add mineral oil keeping existing plugs. Should the user wish to fill it with synthetic oil, it is recommended to replace the existing plugs with a closed plug.
See table 1 for lubrication and recommended quantity.
In table 2 please see possible radial loads and axial loads on the gearbox.

I Il riduttore tipo **FC73** è fornito privo di lubrificazione con tappi di sfiato, livello e scarico olio. L'utente può immettere olio minerale mantenendo i tappi esistenti. Se immetterà olio sintetico, dovrà sostituire i tappi esistenti con altri tipo chiuso.
Tab.1 per oli e quantità consigliati.
Tab.2 carichi radiali e assiali applicabili al riduttore.

D Das Getriebe der Baugröße **FC73** wird ohne Schmiermittel geliefert. Es ist jedoch mit Einfüllschraube, Überdruckventil und Ablassschraube ausgerüstet. Das benötigte mineralische Öl kann über die Einfüllschraube eingefüllt werden. Sollte synthetisches Öl bevorzugt werden, so ist sind das eingebaute Überdruckventil durch eine geschlossenen Schraube zu ersetzen.
In Tabelle 1 ist die Schmiermenge und das empfohlene Schmiermittel angegeben
In Tabelle 2 sind die zulässigen Radial - und Axialbelastungen des Getriebes aufgeführt.

F Le réducteur de type **FC73** est fourni sans lubrification et avec un bouchon de remplissage, de niveau et d'évacuation de l'huile. L'utilisateur peut y verser de l'huile minérale en conservant les bouchons existants. S'il y versera de l'huile synthétique, il devra substituer les bouchons existants avec d'autres bouchons de type fermé.
Voir tableau 1 concernant les huiles et les quantités conseillées.
Voir tableau 2 concernant les charges radiales et axiales applicables au réducteur

E El reductor tamaño **FC73** se suministra sin lubricante, provisto de tapones de respiración, nivel y descarga de aceite. El usuario puede utilizar aceite mineral, manteniendo los tapones existentes. Si prefiere utilizar aceite sintético deberá sustituir los tapones existentes por tapones ciegos. La prerreducción se suministra con tapones ciegos, lubricado de por vida con aceite sintético.
Ver tabla 1, para cantidades y aceites recomendados.
En la tabla 2, se encuentran las cargas radiales y axiales admitidas por el reductor.

H1	H4	H3	H2	H5	H6
3.55 LT	1.95 LT	1.95 LT	1.95 LT	3.75 LT	2.00 LT
SHELL Omala S2 GX 460			ENI Blasia 460		

For all details on lubrication and plugs check our website **tab. 1**
Per maggiori dettagli su lubrificazione e tappi olio vedi il nostro sito web

RADIAL AND AXIAL LOADS

Output shaft
Albero di uscita

$F_{eq} = F_R \cdot \frac{174.5}{X+134.5}$

n_2	F_A	F_R	n_2	F_A	F_R	n_2	F_A	F_R
300	740	3700	140	860	4300	70	1020	5100
250	800	4000	120	900	4500	40	1300	6500
200	830	4150	85	970	4850	15	1700	8500

On request reinforced bearings to increase loads.
A richiesta cuscinetti rinforzati per aumentare i carichi.

Input shaft
Albero in entrata

n_1	F_A	F_R
1400	400	2000
900	440	2200
500	440	2200

tab. 2

PFC73C... Basic gearbox
Riduttore base

Gearbox weight **30.5 kg**
peso riduttore

M. flanges	Kit code	øF	A
63B5	K063.4.041	140	250.5
71B5	K063.4.042	160	248.5
80/90B5	K063.4.043	200	250.5
71B14	K063.4.047	105	248.5
80B14	K063.4.046	120	250.5
90B14	K063.4.041	140	250.5

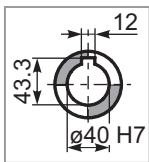
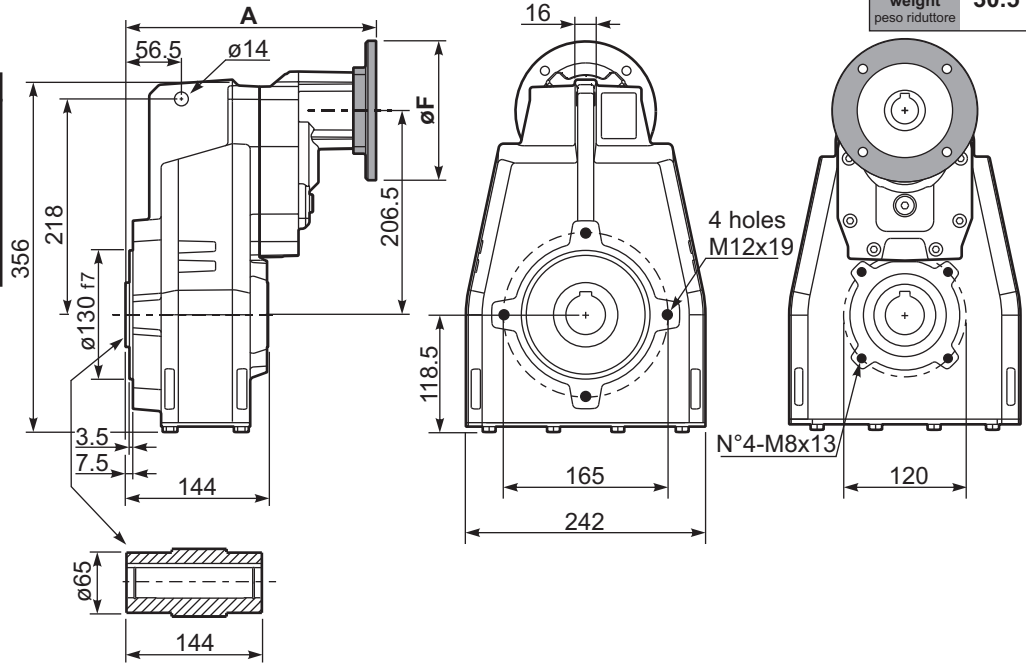

Standard
Hollow shaft

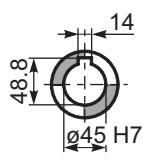

On request
A richiesta

PFC73...-F... Output flange
Flangia uscita

M. flanges	k1
63B5	283
71B5	281
80/90B5	283
71B14	281
80B14	283
90B14	283

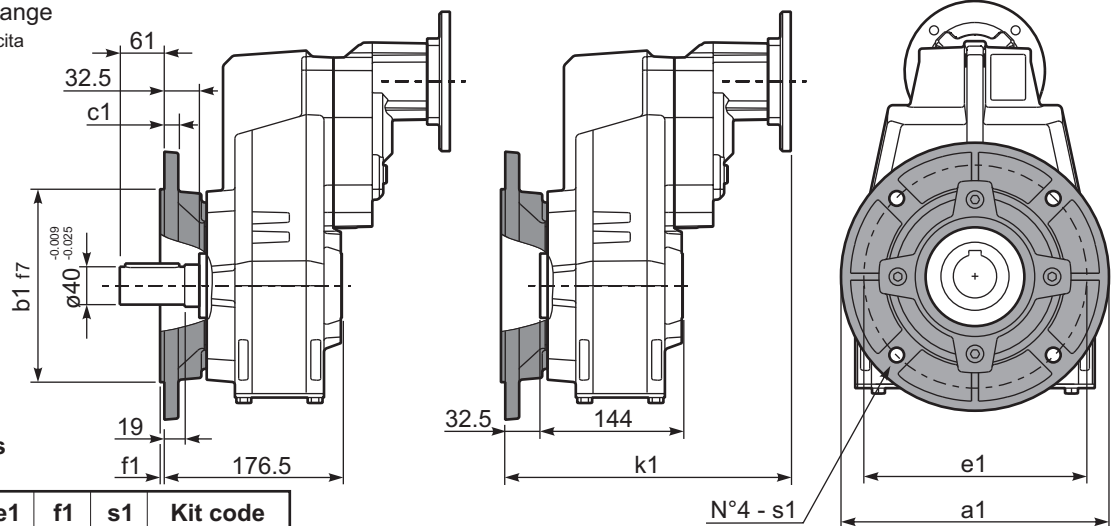

Available output flanges
Flange di uscita

a1 ø	b1	c1	e1	f1	s1	Kit code
250	180	13	215	3	14	KF70.9.011
300	230	16	265	4	14	KF70.9.012

RFC73C... Input Shaft
Albero in entrata

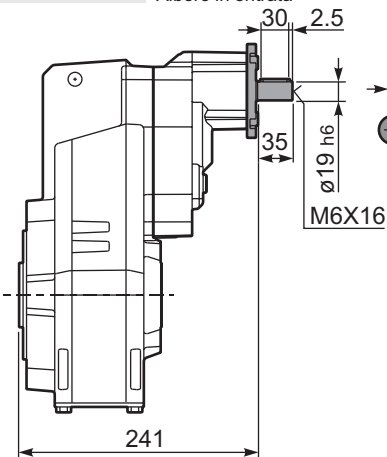

PFC73 A... Single output shaft
Albero uscita semplice

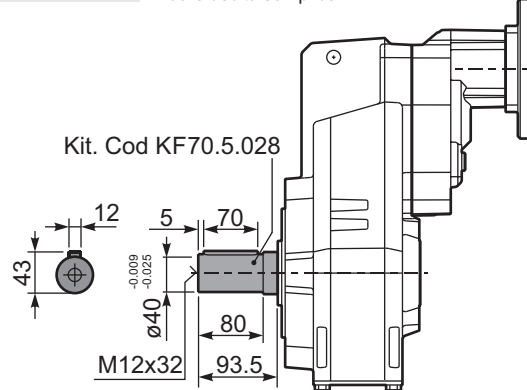

Kit. Cod KF70.5.028

PFC73D... Shrink disk
Calettatore

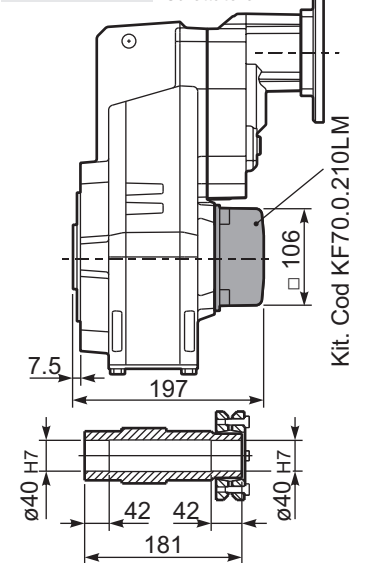

Kit. Cod KF70.0.210LM



QUICK SELECTION / Selezione veloce

input speed (n_1) = 1400 min⁻¹

Output Speed n_2 [min ⁻¹]	Ratio i	Motor power P_{1M} [kW]	Output torque M_{2M} [Nm]	Service factor f.s.	Nominal power P_{1R} [kW]	Nominal torque M_{2R} [Nm]	Available B5 motor flanges		B14 motor flanges				Output Shaft	Ratios code	
							-H	-I	-	-	-	-			-
528	2.65	22	374	1.7	36.7	650			not available				2361	standard	01
409	3.42	22	483	1.6	32.8	750			not available				1965	ø50	02
304	4.60	22	649	1.5	30.9	950			not available				1569		03
256	5.46	22	771	1.3	27.4	1000			not available				1371	ø55	04
211	6.64	22	937	1.3	26.5	1175			not available				1173	On request	05

The dynamic efficiency is **0.98** for all ratios

A) Motor Flanges Available
Flange Motore Disponibili

B) Supplied with Reduction Bushing
Fornito con Bussola di Riduzione

B) Available on Request without reduction bushing
Disponibile a Richiesta senza Bussola di Riduzione

C) Motor Flange Holes Position
Posizione Fori Flangia Motore

EN Unit **FC81** is supplied without lubricant and equipped with a breather, level and drain plugs. User can add mineral oil keeping existing plugs. Should the user wish to fill it with synthetic oil, it is recommended to replace the existing plugs with a closed plug.
See table 1 for lubrication and recommended quantity. In table 2 please see possible radial loads and axial loads on the gearbox.

I Il riduttore tipo **FC81** è fornito privo di lubrificazione con tappi di sfiato, livello e scarico olio. L'utente può immettere olio minerale mantenendo i tappi esistenti. Se immetterà olio sintetico, dovrà sostituire i tappi esistenti con altri tipo chiuso.
Tab.1 per oli e quantità consigliati.
Tab.2 carichi radiali e assiali applicabili al riduttore.

D Das Getriebe der Baugröße **FC81** wird ohne Schmiermittel geliefert. Es ist jedoch mit Einfüllschraube, Überdruckventil und Ablassschraube ausgerüstet. Das benötigte mineralische Öl kann über die Einfüllschraube eingefüllt werden. Sollte synthetisches Öl bevorzugt werden, so ist sind das eingebaute Überdruckventil durch eine geschlossenen Schraube zu ersetzen.
In Tabelle 1 ist die Schmiermenge und das empfohlene Schmiermittel angegeben
In Tabelle 2 sind die zulässigen Radial - und Axialbelastungen des Getriebes aufgeführt.

F Le réducteur de type **FC81** est fourni sans lubrification et avec un bouchon de remplissage, de niveau et d'évacuation de l'huile. L'utilisateur peut y verser de l'huile minérale en conservant les bouchons existants. S'il y versera de l'huile synthétique, il devra substituer les bouchons existants avec d'autres bouchons de type fermé.
Voir tableau 1 concernant les huiles et les quantités conseillées.
Voir tableau 2 concernant les charges radiales et axiales applicables au réducteur

E El reductor tamaño **FC81** se suministra sin lubricante, provisto de tapones de respiración, nivel y descarga de aceite. El usuario puede utilizar aceite mineral, manteniendo los tapones existentes. Si prefiere utilizar aceite sintético deberá sustituir los tapones existentes por tapones ciegos. La prerreducción se suministra con tapones ciegos, lubricado de por vida con aceite sintético.
Ver tabla 1, para cantidades y aceites recomendados.
En la tabla 2, se encuentran las cargas radiales y axiales admitidas por el reductor.

H1	H4	H3	H2	H5	H6
5.50 LT	3.50 LT	3.50 LT	3.50 LT	6.20 LT	4.40 LT
SHELL Omala S2 GX 460			ENI Blasias 460		

For all details on lubrication and plugs check our website **tab. 1**
Per maggiori dettagli su lubrificazione e tappi olio vedi il nostro sito web

RADIAL AND AXIAL LOADS

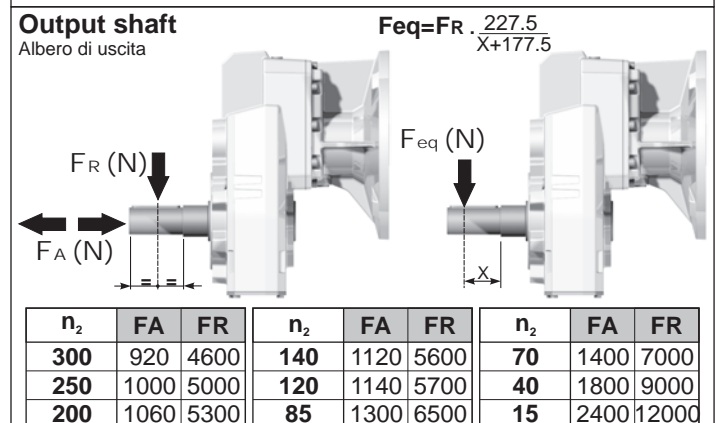

On request reinforced bearings to increase loads.
A richiesta cuscinetti rinforzati per aumentare i carichi.

tab. 2

PFC81C...

Basic gearbox
Riduttore base

Gearbox weight
peso riduttore **78.0 kg**

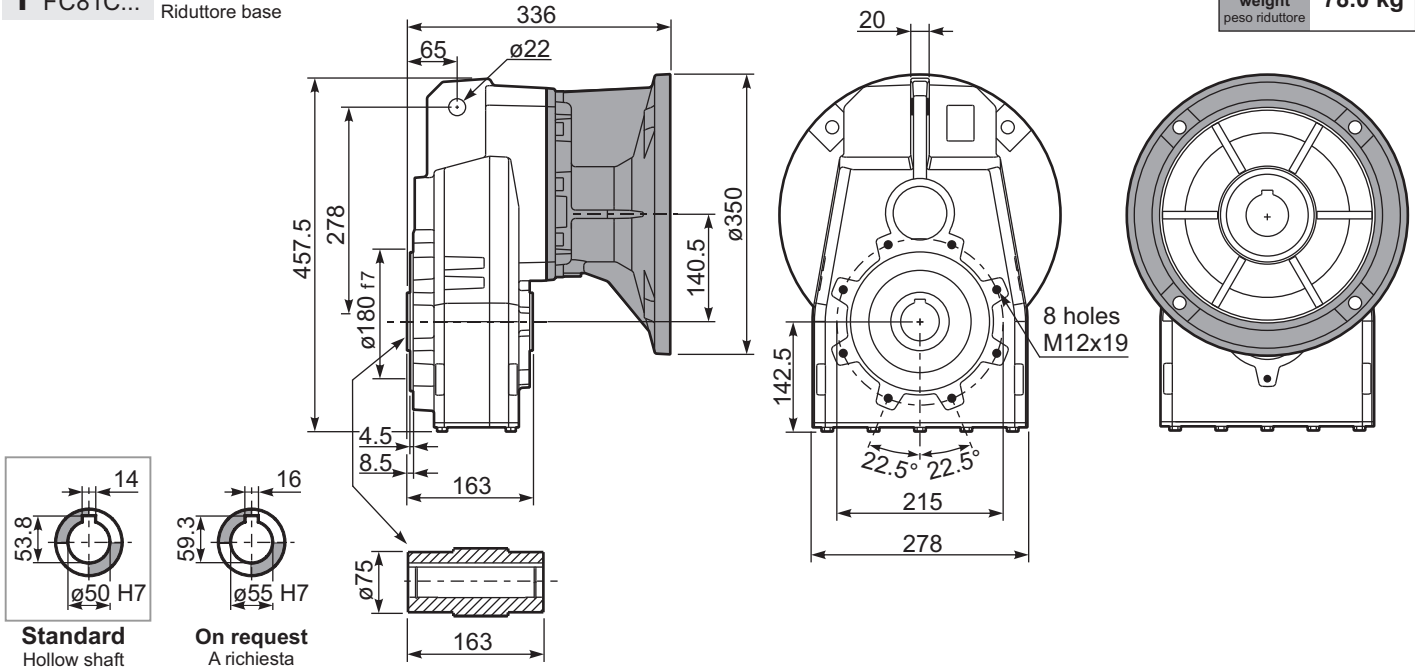

PFC81...-F...

Output flange
Flangia uscita

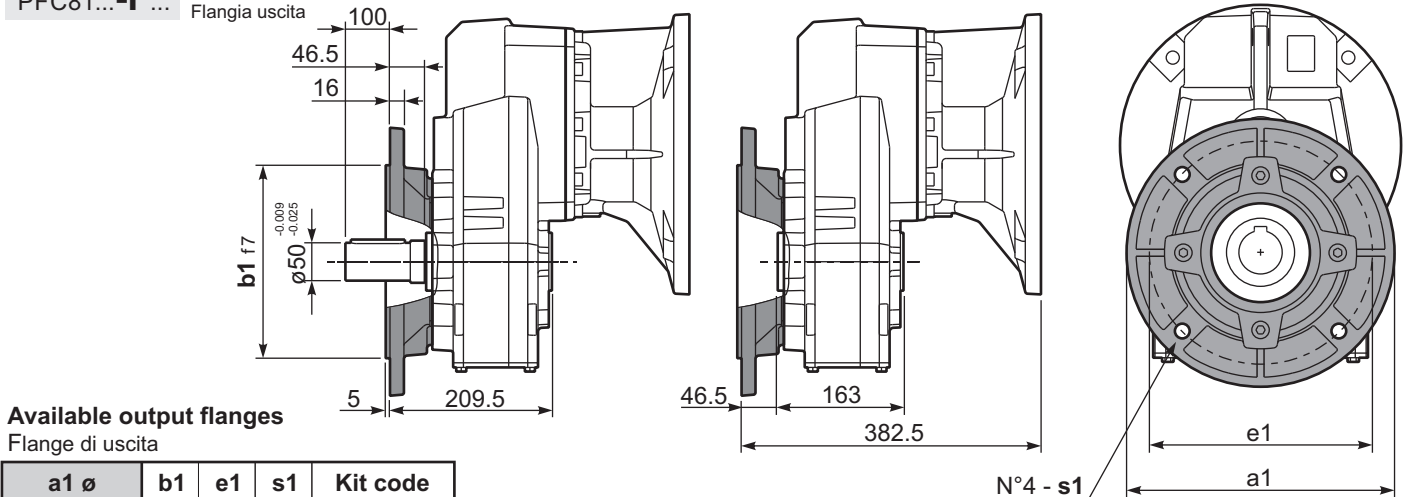

PFC81A...

Single output shaft
Albero uscita semplice

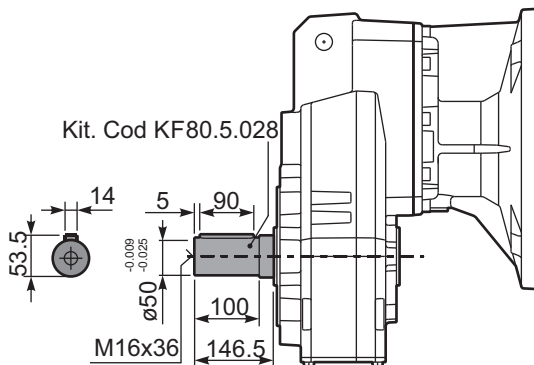



QUICK SELECTION / Selezione veloce

input speed (n_1) = 1400 min⁻¹

Output Speed n_2 [min ⁻¹]	Ratio i	Motor power P_{1M} [kW]	Output torque M_{2M} [Nm]	Service factor f.s.	Nominal power P_{1R} [kW]	Nominal torque M_{2R} [Nm]	B5 motor flanges				B14 motor flanges		Output Shaft		
							-F	-G	-H	-I	-U	-V			Ratios code
							100 112	132	160	180	100 112	132	\varnothing		
234	5.98	22	827	1.2	25.5	1000						3015		01	
197	7.10	22	982	1.2	25.3	1175						3013		02	
162	8.63	22	1193	1.1	23.9	1350						3011		03	
124	11.27	18.5	1310	1.1	20.3	1500						2015		04	
105	13.38	18.5	1555	1.1	19.4	1700						2013		05	
92	15.24	18.5	1771	1.1	19.0	1900						1615		06	
86	16.26	18.5	1889	1.1	19.7	2100						2011	standard $\varnothing 50$	07	
77	18.09	18.5	2102	1.0	17.7	2100						1613			08
71	19.82	15	1865	1.1	15.9	2060						1315	$\varnothing 55$ On request	09	
64	21.98	15	2069	1.0	14.6	2100						1611			10
60	23.53	15	2214	0.9	13.6	2100						1313		11	
58	24.25	11	1677	1.2	12.2	1940						1115		12	
48.6	28.80	11	1991	1.1	11.1	2100						1113		13	
40.0	34.99	9	2063	1.0	9.2	2100						1111		14	
33.6	41.64	7.5	1976	1.0	7.2	1960						813		15	
27.7	50.60	5.5	1774	1.2	6.3	2100						811		16	

The dynamic efficiency is **0.96** for all ratios

- Motor Flanges Available**
Flange Motore Disponibili
- B) Supplied with Reduction Bushing**
Fornito con Bussola di Riduzione
- B) Available on Request without reduction bushing**
Disponibile a Richiesta senza Bussola di Riduzione
- C) Motor Flange Holes Position**
Posizione Fori Flangia Motore

EN Unit **FC82** is supplied without lubricant and equipped with a breather, level and drain plugs. User can add mineral oil keeping existing plugs. Should the user wish to fill it with synthetic oil, it is recommended to replace the existing plugs with a closed plug.
See table 1 for lubrication and recommended quantity. In table 2 please see possible radial loads and axial loads on the gearbox.

I Il riduttore tipo **FC82** è fornito privo di lubrificazione con tappi di sfiato, livello e scarico olio. L'utente può immettere olio minerale mantenendo i tappi esistenti. Se immetterà olio sintetico, dovrà sostituire i tappi esistenti con altri tipo chiuso.
Tab.1 per oli e quantità consigliati.
Tab.2 carichi radiali e assiali applicabili al riduttore.

D Das Getriebe der Baugröße **FC82** wird ohne Schmiermittel geliefert. Es ist jedoch mit Einfüllschraube, Überdruckventil und Ablassschraube ausgerüstet. Das benötigte mineralische Öl kann über die Einfüllschraube eingefüllt werden. Sollte synthetisches Öl bevorzugt werden, so ist sind das eingebaute Überdruckventil durch eine geschlossenen Schraube zu ersetzen.
In Tabelle 1 ist die Schmiermenge und das empfohlene Schmiermittel angegeben
In Tabelle 2 sind die zulässigen Radial - und Axialbelastungen des Getriebes aufgeführt.

F Le réducteur de type **FC82** est fourni sans lubrification et avec un bouchon de remplissage, de niveau et d'évacuation de l'huile. L'utilisateur peut y verser de l'huile minérale en conservant les bouchons existants. S'il y versera de l'huile synthétique, il devra substituer les bouchons existants avec d'autres bouchons de type fermé.
Voir tableau 1 concernant les huiles et les quantités conseillées.
Voir tableau 2 concernant les charges radiales et axiales applicables au réducteur

E El reductor tamaño **FC82** se suministra sin lubricante, provisto de tapones de respiración, nivel y descarga de aceite. El usuario puede utilizar aceite mineral, manteniendo los tapones existentes. Si prefiere utilizar aceite sintético deberá sustituir los tapones existentes por tapones ciegos. La prerreducción se suministra con tapones ciegos, lubricado de por vida con aceite sintético. Ver tabla 1, para cantidades y aceites recomendados. En la tabla 2, se encuentran las cargas radiales y axiales admitidas por el reductor.

H1	H4	H3	H2	H5	H6
5.70 LT	3.60 LT	3.60 LT	3.60 LT	6.60 LT	4.50 LT
SHELL Omala S2 GX 460			ENI Blasias 460		

For all details on lubrication and plugs check our website [www.fc82.com](#) **tab. 1**
Per maggiori dettagli su lubrificazione e tappi olio vedi il nostro sito web

RADIAL AND AXIAL LOADS

Output shaft
Albero di uscita

$F_R(N)$ $F_A(N)$ $F_{eq} = F_R \cdot \frac{227.5}{X+177.5}$

n_2	F_A	F_R	n_2	F_A	F_R	n_2	F_A	F_R
300	920	4600	140	1120	5600	70	1400	7000
250	1000	5000	120	1140	5700	40	1800	9000
200	1060	5300	85	1300	6500	15	2400	12000

On request reinforced bearings to increase loads.
A richiesta cuscinetti rinforzati per aumentare i carichi.

Input shaft
Albero in entrata

$F_R(N)$ $F_A(N)$

n_1	F_A	F_R
1400	700	3500
900	840	4200
500	900	4500

tab. 2

PFC82C... Basic gearbox
Riduttore base

Gearbox weight
peso riduttore **82.5 kg**

M. flanges	Kit code	øF	A
100/112B5	K023.4.043	250	299
132B5	KC51.4.043C	300	320.5
160/180B5	KC86.4.0.43	350	352.5
100/112B14	K085.4.047	160	299
132B14	KC51.4.041C	200	320.5

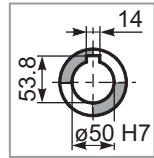
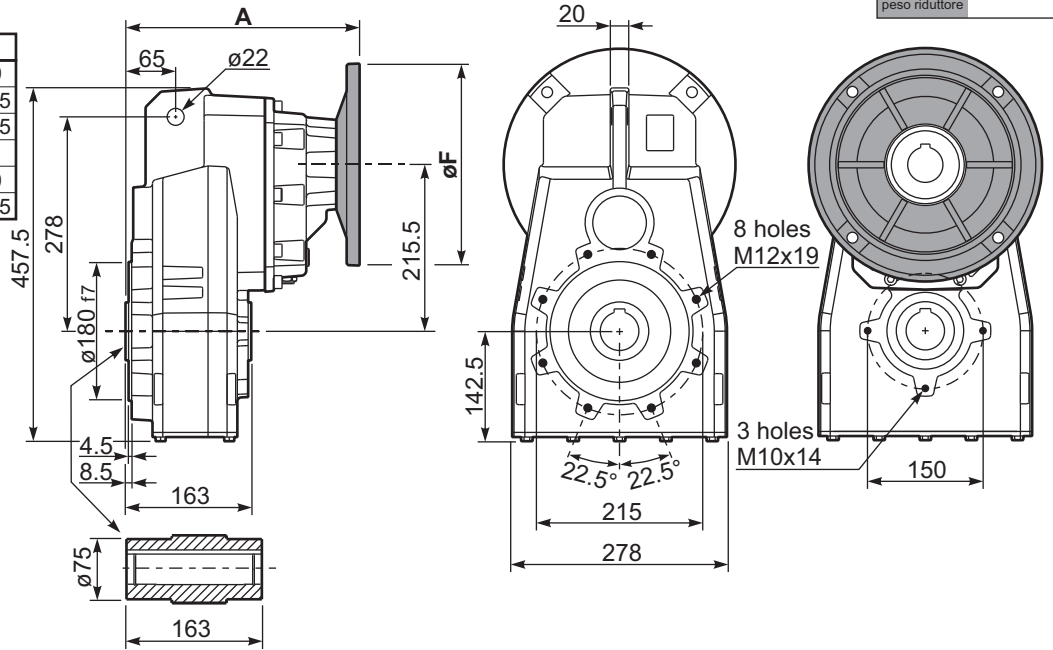

Standard
Hollow shaft

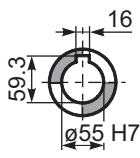

On request
A richiesta

PFC82...-F... Output flange
Flangia uscita

M. flanges	k1
100/112B5	345.5
132B5	367
160/180B5	399
100/112B14	345.5
132B14	367

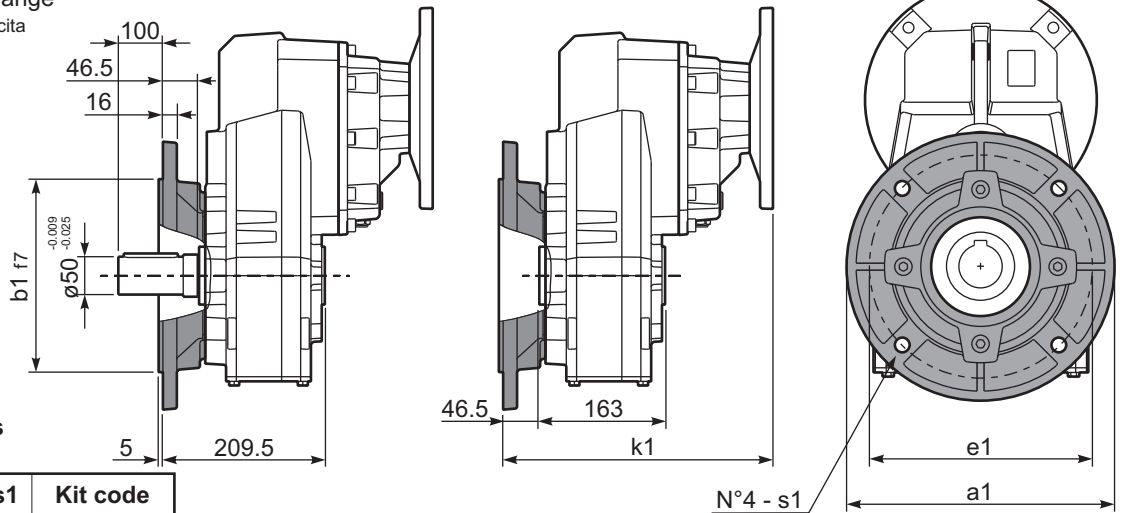

Available output flanges
Flangia di uscita

a1 ø	b1	e1	s1	Kit code
300	230	265	14	KF80.9.011
350	250	300	18	KF80.9.012

RFC82C... Input Shaft
Albero in entrata

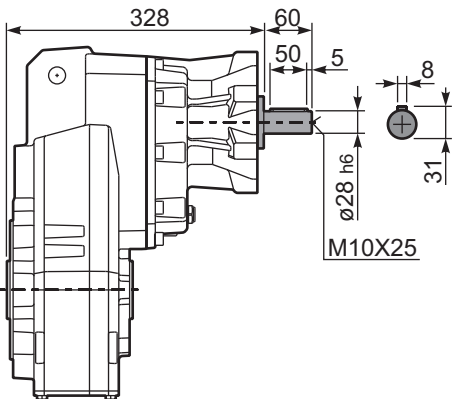

PFC82 A... Single output shaft
Albero uscita semplice

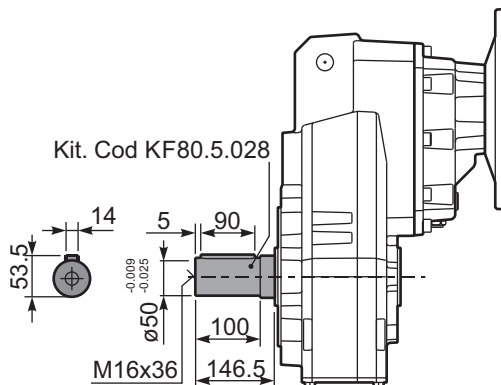

Kit. Cod KF80.5.028

PFC82 D... Shrink disk
Calettatore

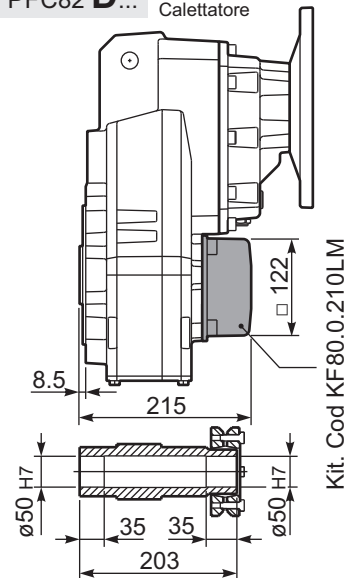

Kit. Cod KF80.0.210LM



QUICK SELECTION / Selezione veloce

input speed (n₁) = 1400 min⁻¹

Output Speed n ₂ [min ⁻¹]	Ratio i	Motor power P _{1M} [kW]	Output torque M _{2M} [Nm]	Service factor f.s.	Nominal power P _{1R} [kW]	Nominal torque M _{2R} [Nm]	Available B5 motor flanges					Available B14 motor flanges				Output Shaft	Ratios code	
							-C	-D	-E	-F	-G	-R	-T	-U	-V			
							71	80	90	100 112	132	80	90	100 112	132			
28.8	48.55	7.5	2257	0.9	6.7	2100	B									201315	standard ø50	01
24.3	57.64	5.5	1980	1.1	5.7	2100	B									201313		02
21.3	65.64	5.5	2255	0.9	5.0	2100	B									161315		03
20.0	70.04	4	1760	1.2	4.7	2100	B									201311		04
18.0	77.93	4	1958	1.1	4.2	2100	B									161313		05
16.4	85.36	4	2145	1.0	3.8	2100	B									131315		06
14.8	94.70	4	2380	0.9	3.5	2100	B									161311		07
13.8	101.35	3	1917	1.1	3.2	2100	B									131313		08
11.4	123.15	3	2330	0.9	2.7	2100	B									131311		09
9.3	150.73	2.2	2100	1.0	2.2	2100	B									111311		10
7.8	179.39	1.5	1722	1.2	1.8	2100	B									81313		11
6.4	217.98	1.5	2093	1.0	1.5	2100	B									81311		12
5.7	247.03	1.1	1732	1.1	1.2	1950	B									61313		13
4.7	300.17	1.1	2105	1.0	1.1	2100	B									61311		14

The dynamic efficiency is **0.94** for all ratios

- Motor Flanges Available** Flange Motore Disponibili
- Supplied with Reduction Bushing** Fornito con Bussola di Riduzione
- Available on Request without reduction bushing** Disponibile a Richiesta senza Bussola di Riduzione
- Motor Flange Holes Position** Posizione Fori Flangia Motore

EN Unit **FC83** is supplied without lubricant and equipped with a breather, level and drain plugs. User can add mineral oil keeping existing plugs. Should the user wish to fill it with synthetic oil, it is recommended to replace the existing plugs with a closed plug. See table 1 for lubrication and recommended quantity. In table 2 please see possible radial loads and axial loads on the gearbox.

I Il riduttore tipo **FC83** è fornito privo di lubrificazione con tappi di sfianto, livello e scarico olio. L'utente può immettere olio minerale mantenendo i tappi esistenti. Se immetterà olio sintetico, dovrà sostituire i tappi esistenti con altri tipo chiuso. Tab.1 per oli e quantità consigliati. Tab.2 carichi radiali e assiali applicabili al riduttore.

D Das Getriebe der Baugröße **FC83** wird ohne Schmiermittel geliefert. Es ist jedoch mit Einfüllschraube, Überdruckventil und Ablassschraube ausgerüstet. Das benötigte mineralische Öl kann über die Einfüllschraube eingefüllt werden. Sollte synthetisches Öl bevorzugt werden, so ist sind das eingebaute Überdruckventil durch eine geschlossenen Schraube zu ersetzen. In Tabelle 1 ist die Schmiermenge und das empfohlene Schmiermittel angegeben. In Tabelle 2 sind die zulässigen Radial - und Axialbelastungen des Getriebes aufgeführt.

F Le réducteur de type **FC83** est fourni sans lubrification et avec un bouchon de remplissage, de niveau et d'évacuation de l'huile. L'utilisateur peut y verser de l'huile minérale en conservant les bouchons existants. S'il y versera de l'huile synthétique, il devra substituer les bouchons existants avec d'autres bouchons de type fermé. Voir tableau 1 concernant les huiles et les quantités conseillées. Voir tableau 2 concernant les charges radiales et axiales applicables au réducteur.

E El reductor tamaño **FC83** se suministra sin lubricante, provisto de tapones de respiración, nivel y descarga de aceite. El usuario puede utilizar aceite mineral, manteniendo los tapones existentes. Si prefiere utilizar aceite sintético deberá sustituir los tapones existentes por tapones ciegos. La prerreducción se suministra con tapones ciegos, lubricado de por vida con aceite sintético. Ver tabla 1, para cantidades y aceites recomendados. En la tabla 2, se encuentran las cargas radiales y axiales admitidas por el reductor.

H1	H4	H3	H2	H5	H6
5.80 LT	3.90 LT	3.90 LT	3.90 LT	6.80 LT	4.90 LT
SHELL Omala S2 GX 460			ENI Blasias 460		

For all details on lubrication and plugs check our website **tab. 1**
Per maggiori dettagli su lubrificazione e tappi olio vedi il nostro sito web

RADIAL AND AXIAL LOADS

Output shaft
Albero di uscita

$F_{eq} = F_R \cdot \frac{227.5}{X+177.5}$

n ₂	FA	FR	n ₂	FA	FR	n ₂	FA	FR
300	920	4600	140	1120	5600	70	1400	7000
250	1000	5000	120	1140	5700	40	1800	9000
200	1060	5300	85	1300	6500	15	2400	12000

On request reinforced bearings to increase loads.
A richiesta cuscinetti rinforzati per aumentare i carichi.

Input shaft
Albero in entrata

n ₁	FA	FR
1400	450	2250
900	500	2500
500	600	3000

tab. 2

PFC83C... Basic gearbox
Riduttore base

Gearbox weight **68.5 kg**
peso riduttore

M. flanges	Kit code	øF	A
71B5	K023.4.041	160	292.5
80/90B5	K023.4.042	200	294.5
100/112B5	K023.4.043	250	303.5
132B5	KC51.4.043	300	324.5
80B14	K085.4.046	120	294.5
90B14	K085.4.045	140	294.5
100/112B14	K085.4.047	160	303.5
132B14	KC51.4.041	200	324.5

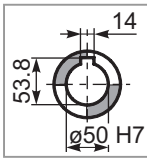
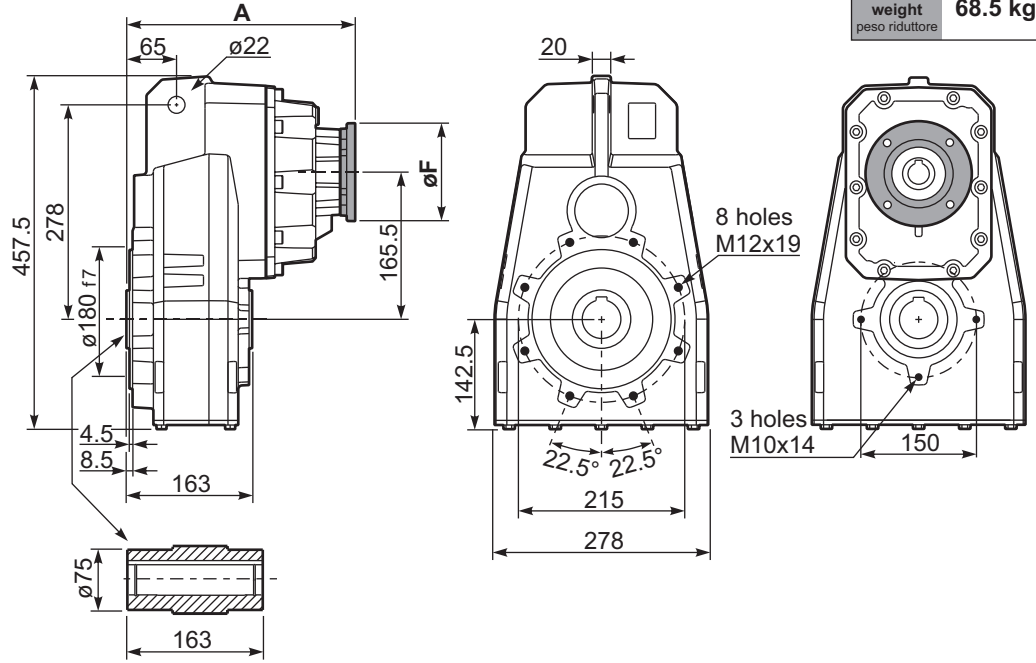

Standard
Hollow shaft

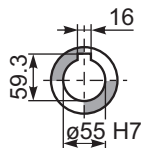

On request
A richiesta

PFC83...-F... Output flange
Flangia uscita

M. flanges	k1
71B5	339
80/90B5	341
100/112B5	350
132B5	368
80B14	341
90B14	341
100/112B14	350
132B14	368

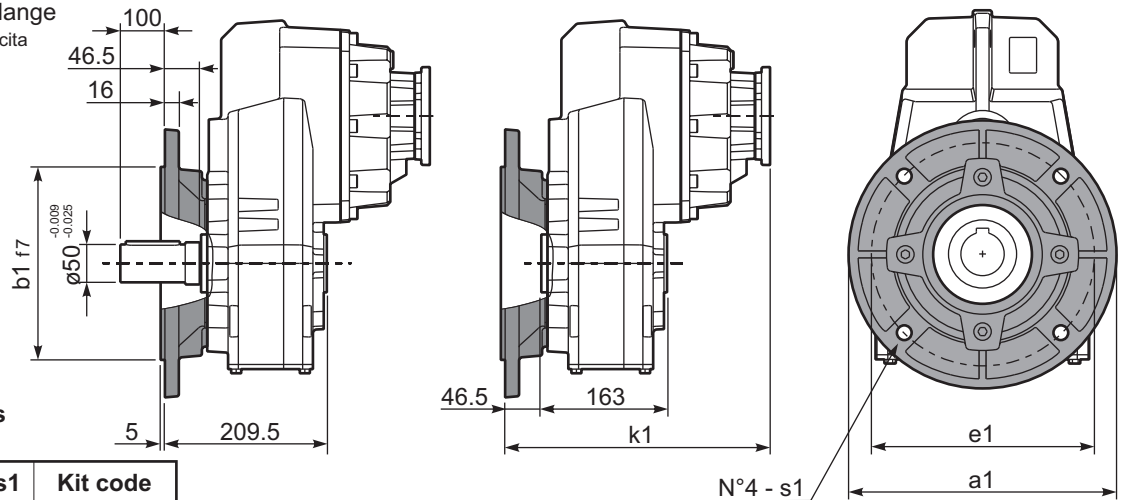

Available output flanges
Flange di uscita

a1 ø	b1	e1	s1	Kit code
300	230	265	14	KF80.9.011
350	250	300	18	KF80.9.012

RFC83C... Input Shaft
Albero in entrata

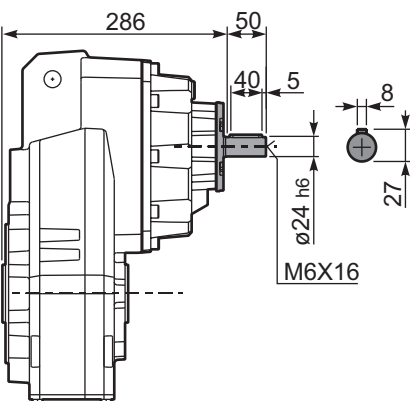

PFC83 A... Single output shaft
Albero uscita semplice

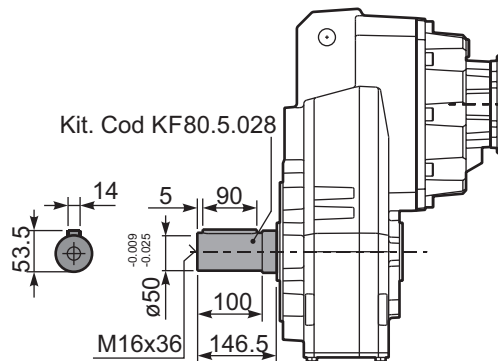

PFC83D... Shrink disk
Calettatore
Kit. Cod KF80.0.210LM

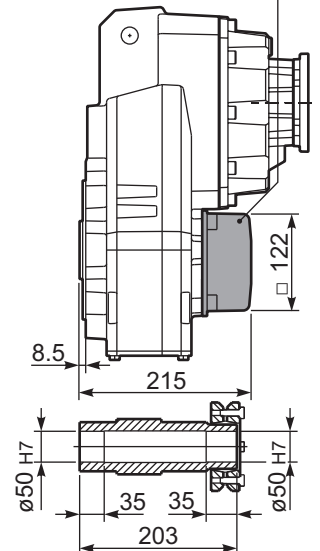

Cast iron parallel shaft gearboxes

A modular and compact product

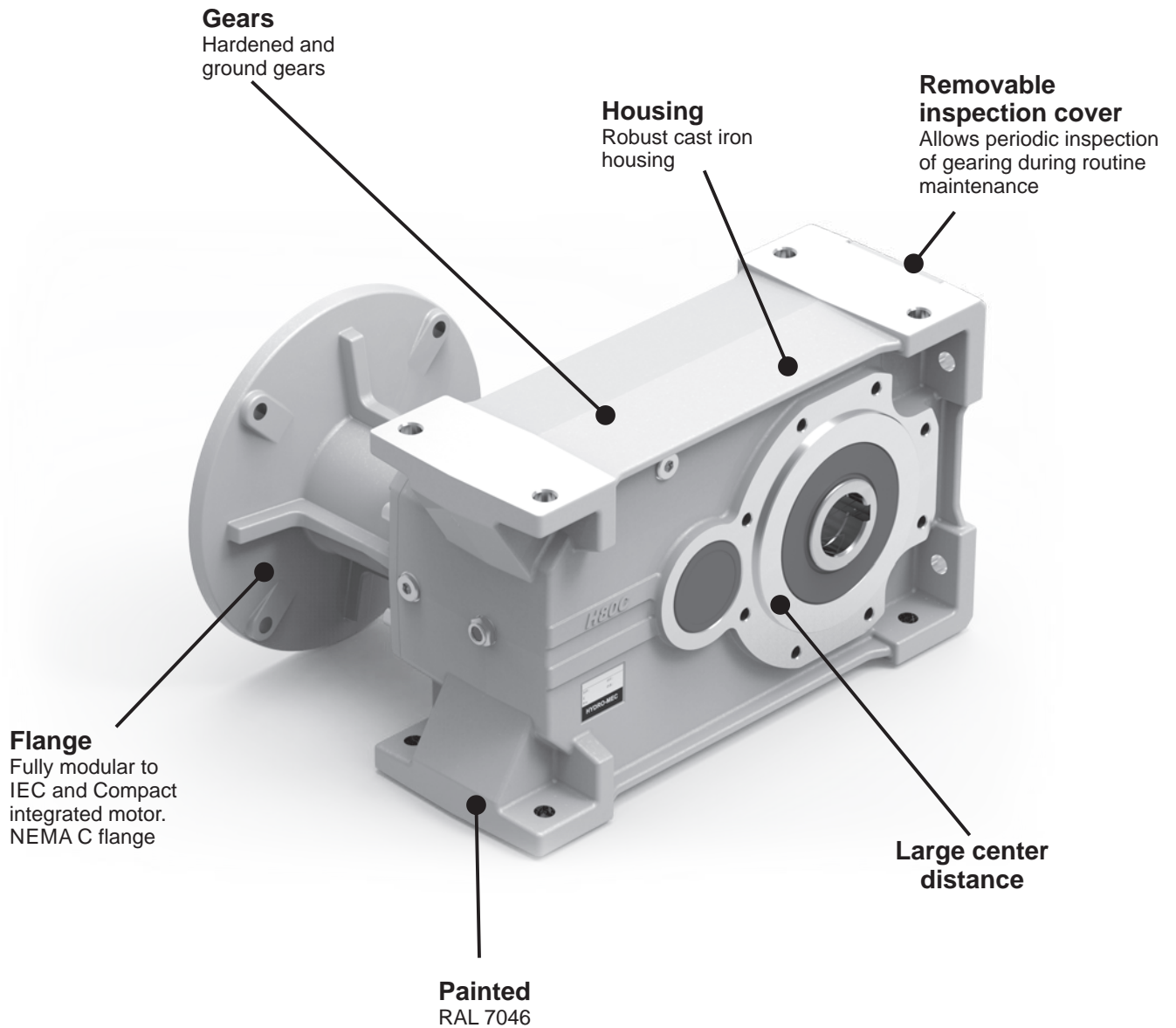

Single-piece Cast Iron housing

with high tensile strength.
Precision machined for alignment of bearings and gearing

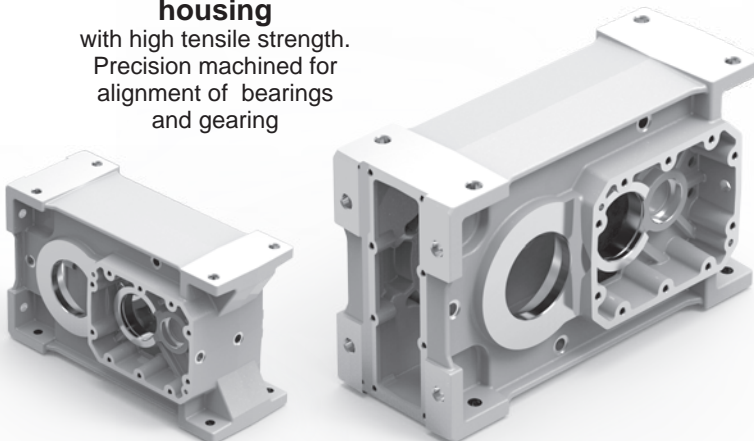

World wide sales network.

Specific type datasheet on page...

On page / A pagina / Auf Seite / À la page / En la página

1 Stage

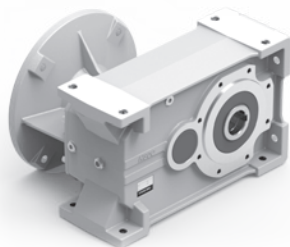

8-5 8-11 8-17

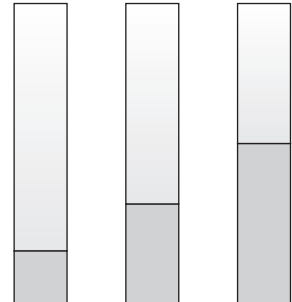

Types / Tipi /
Tipen / Types /
Tipos

⇒ **H61C** 380Nm **H71C** 670Nm **H81C** 1175Nm

On page / A pagina / Auf Seite / À la page / En la página

2 and 3 Stage

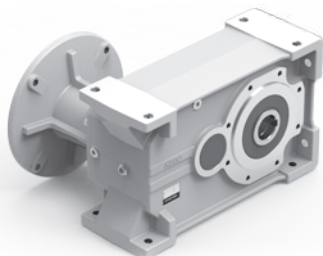

8-7 8-9 8-13 8-15 8-19 8-21

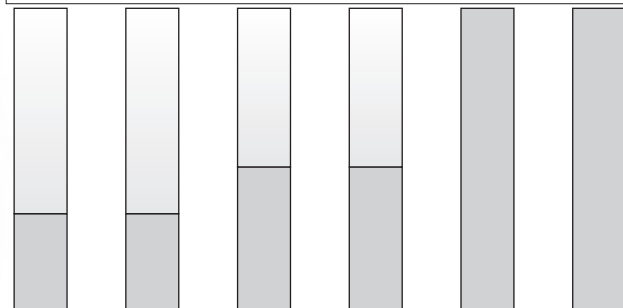

Types / Tipi /
Tipen / Types /
Tipos

⇒ **H62C** 675Nm **H63C** 675Nm **H72C** 900Nm **H73C** 900Nm **H82C** 2100Nm **H83C** 2100Nm

On page / A pagina / Auf Seite / À la page / En la página

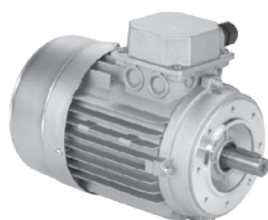

Types / Tipi /
Tipen / Types /
Tipos

M-1

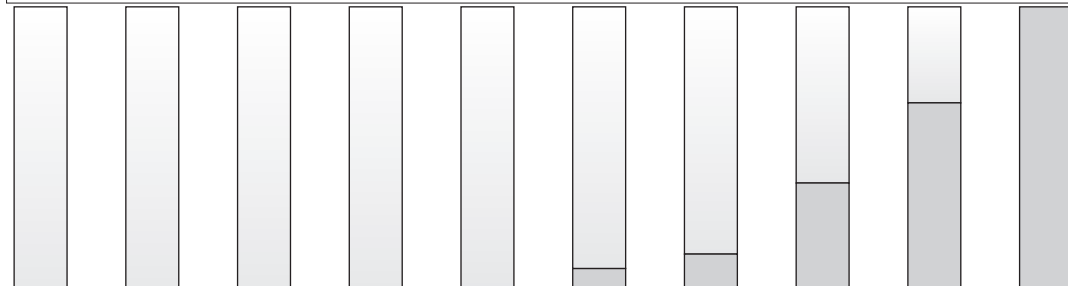



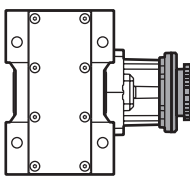
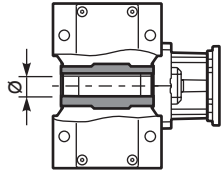
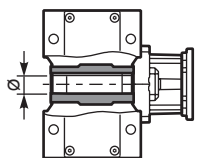
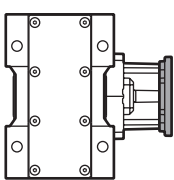
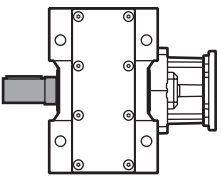
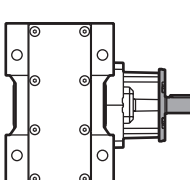
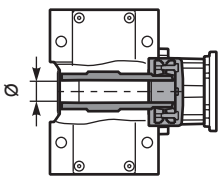
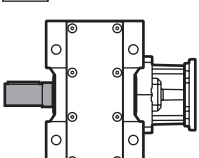
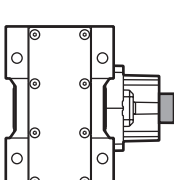
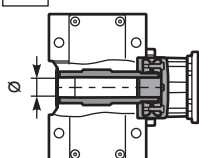





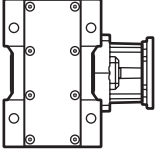
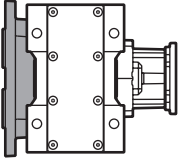

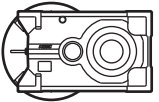
56A 56B 63A 63B 71A 71B 80A 80B 90S 90L 100LA 100LB 112M 132S 132M 160M 160L 180M 180L

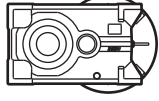
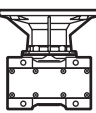
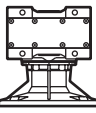
Type - Tipo - Typ Type - Tipo	Size - Grandezza - Grösse Taille - Tamaño	Mounting - Montaggio Montage - Fixation Tipo de montaje	Rapporto - Ratio Untersetzung Reduction - Relacion	Output shaft Albero uscita Abtriebswelle Arbre de sortie Eje en salida
M	H62C	C	12.39	-E
<p>Parallel shaft helical Riduttori ad assi paralleli</p> 	<p>1 Stage Riduzione Stufe Trains Etapas</p> <p>2 Stages Riduzioni Stufen Trains Etapas</p> <p>3 Stages Riduzioni Stufen Trains Etapas</p> <p style="text-align: center;">Cast Iron/Ghisa/Grauguss/Fonte/Fundicion</p>		<p>See technical data table</p> <p>Vedi tabelle dati tecnici.</p> <p>Technisches Datenblatt beachten</p> <p>Voir Tableau données techniques</p> <p>Ver tabla datos técnicos</p>	<p>C</p> 
<p>With IEC motor M</p>	<p>H61C H71C H81C</p>	<p>Hollow output shaft C</p>		<p>STANDARD Only on request for Q.ty A richiesta per quantità</p>
 <p>With motor flange P</p>	<p>H62C H72C H82C</p> <p>H63C H73C H83C</p>	 <p>Single output shaft A</p>		<p>H61C H62C H63C -E → $\varnothing 35$ -F → $\varnothing 40$</p> <p>H71C H72C H73C -F → $\varnothing 40$ -G → $\varnothing 45$</p> <p>H81C H82C H83C -H → $\varnothing 50$ -I → $\varnothing 55$</p>
 <p>With male input shaft R</p>		 <p>Shrink Disk D</p> <p>Only on request for Q.ty A richiesta per quantità</p>		<p>A</p>  <p>Single output shaft</p> <p>-N H61/2/3C → $\varnothing 35$ -O H71/2/3C → $\varnothing 40$ -K H81/2/3C → $\varnothing 50$</p>
 <p>Modular base B</p> <p>Not available for: H61C, H71C, H81C, H82C</p>				<p>D</p>  <p>Shrink disk</p> <p>-T H62/3C → $\varnothing 35$ -U H72/3C → $\varnothing 40$ -V H82/3C → $\varnothing 50$</p>

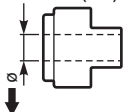
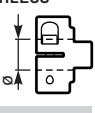
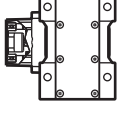

On request we can deliver our products according to the ATEX
 A richiesta possiamo fornire i nostri prodotti secondo le normative ATEX
 Auf Anfrage können wir unsere Produkte den Richtlinien ATEX entsprechend liefern
 Sur demande nos produits peuvent se conformer à la réglementation ATEX
 A pedido, se pueden enviar nuestros productos de acuerdo con las normas ATEX.

Type - Tipo - Typ Types - Tipo	Output flange Flangia uscita Ausgangsflansch Bride de sortie Brida en salida	Motor size - Grandezza motore Motor Größe Grandeur moteur - Tamaño motor	Mounting position Posizione montaggio Einbaulage Position de montage Position de montaje	Input bore Foro entrata Eingangshohlwelle Trou d'entree Eje hueco de entrada	Terminal box position Posizione morsettiere Klemmkastenlage Position boîte à bornes Posición caja de bornes
<p>-N</p>  <p>-N Senza flangia Without flange</p>  <p>-F Whit output flange con flangia uscita</p>	<p>N Senza flangia Without flange</p> <p>H61C H62C H63C</p> <p>4 → ∅250</p> <p>H71C H72C H73C</p> <p>4 → ∅250 5 → ∅300</p> <p>H81C H82C H83C</p> <p>5 → ∅300 6 → ∅350</p>	<p>-C</p> <p>Flange Flangia</p>  <p>B5</p> <p>-A=56 (∅120) -B=63 (∅140) -C=71 (∅160) -D=80 (∅200) -E=90 (∅200) -F=100 (∅250) -G=132 (∅300) -H=160 (∅350) -I=180 (∅350)</p> <p>Without flange Senza flangia</p>  <p>-M → With coupling</p> <p>H63C H73C</p> <p>-1 → ∅14 (71B5) -2 → ∅19 (80B5) -3 → ∅24 (90B5)</p> <p>H62C H72C H83C</p> <p>-2 → ∅19 (80B5) -3 → ∅24 (90B5) -4 → ∅28 (100B5)</p> <p>Brushless</p> <p>BB=50/70-M5 BC=60/75-M5 BD=70/90-M6 BE=80/100-M6 BF=95/115-M8 BG=110/145-M8 BH=130/165-M8</p>	<p>B3</p>  <p>B3 STANDARD</p>  <p>B6</p>  <p>B7</p>  <p>B8</p>  <p>V5</p>  <p>V6</p>  <p>V8</p>	<p>ST</p> <p>standard bore foro standard</p> <p>COUPLING STANDARD (IEC)</p>  <p>-A = 9mm -B = 11mm -C = 14mm -D = 19mm -E = 24mm -F = 28mm</p> <p>BRUSHLESS *</p>  <p>-3 = 14mm -4 = 19mm -5 = 22mm -6 = 24mm</p> <p>-0</p> <p>Ready for input coupling Predisposto per giunto</p>  <p>* With reduction bushing where applicable Con bussola di riduzione dove prevista</p>	<p>With Type M specify terminal box position Con tipo M specificare posizione morsettiere</p>  <p>A</p>  <p>B STANDARD</p>  <p>C</p>  <p>D</p>

POTENZA RICHIESTA / REQUIRED POWER / ERFORDERLICHE LEISTUNG / PUISSANCE NECESSAIRE / POTENCIA NECESARIA

Lifting / sollevamento / hubantriebe / levage / elevación

$$P \text{ [KW]} = \frac{M \text{ [Kg]} \cdot g \text{ [9.81]} \cdot v \text{ [m / s]}}{1000}$$

Rotation / rotazione / drehung / rotation / rotacion

$$P \text{ [KW]} = \frac{M \text{ [Nm]} \cdot n \text{ [rpm]}}{9550}$$

Linear movement / traslazione / linearbewegung / translation / translacion

$$P \text{ [KW]} = \frac{F \text{ [N]} \cdot v \text{ [m / s]}}{1000}$$

TORQUE / COPPIA / DREHMOMENT / COUPLE / PAR

$$M \text{ [Nm]} = \frac{9550 \cdot P \text{ [KW]}}{n \text{ [rpm]}}$$

$$M \text{ [lb in]} = \frac{63030 \cdot P \text{ [HP]}}{n \text{ [rpm]}}$$

RADIAL LOADS / CARICHI RADIALI / RADIALE - UND AXIALLASTEN / CHARGES RADIALES / CARGA RADIAL Y AXIAL

- Radial load generated by external transmissions keyed onto input and/or output shafts.
- Forza radiale generata da organi di trasmissione calettati sugli alberi di ingresso e/o uscita.
- Belastungen der Antriebs- bzw. Abtriebswellen durch von aussen eingebrachte Radiallasten.
- Charge radiale générée par la transmissions calés sur les entrées et / ou des arbres de sortie
- Cargas radiales, generada por transmisiones externas, aplicadas sobre los ejes de entrada y/o salida

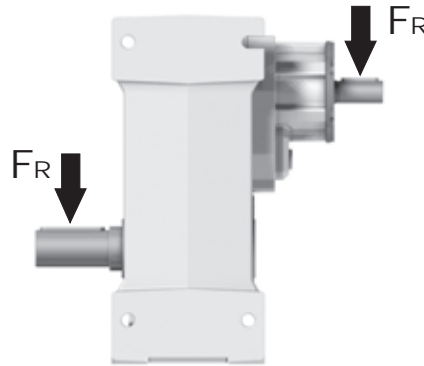

$$F_R \text{ [N]} = \frac{M \text{ [Nm]} \cdot 2000}{d \text{ [mm]}} \cdot f_k$$

$$F_R \text{ [N]} = \frac{M \text{ [lb in]} \cdot 8.9}{d \text{ [in]}} \cdot f_k$$

M	Momento torcente / Output torque / Abtriebsdrehmoment / Couple / Par torsion
d	Diametro primitivo / Diam. of driving element / Durchmesser der Abtriebseinheit / Diamètre primitif / Diámetro primitivo
f_k	Coefficiente di trasformazione / Factor / Faktor / Coefficient de transmission / Coeficiente de transmisión 1.15 Ingranaggi / Gearwheels / Zahnrad / Engrenage / Engranaje 1.25 Catena / Chain sprochets / Antriebskette / Chaîne / Cadena 1.75 Cinghia Trapezoidale / Narrow v-belt pulley / Keilriemen / Courroie trap. / Correa trapezoidal 2.50 Cinghia piatta / Flat-belt pulley / Flachzahnriem. / Courroie crantée / Correa plana

- If your application requires higher radial loads, contact our technical office. Higher load may be possible.
- Nel caso la vostra applicazione richieda carichi radiali superiori consultare il nostro ufficio tecnico, valori maggiori possono essere accettati.
- Wenn Ihre Anwendung höhere Radialbelastungen erfordert, so wenden Sie sich bitte an unser technischen Büro.
- Si votre application demande des charges radiales supérieures, s'adresser à notre bureau technique.
- En el caso en que una aplicación exija una carga radial superior a la especificada en el catálogo, consultar a nuestra oficinas técnica.

How to select a gearbox / Come selezionare un riduttore / Wie wählt man ein Getriebe
Comment sélectionner un réducteur / Cómo seleccionar un reductor

B Output speed
Velocità in uscita
Abtriebsdrehzahl
Vitesse de sortie
Velocidad de salida

Nominal power
Potenza nominale
Max. mögliche Leistung
Puissance nominale
Potencia nominal

A Nominal torque
Momento torcente nominale
Nenn Drehmoment
Couple nominal
Par de torsión nominal

Flange code
Codice flangia
Flanschttype
Code bride
Código bridas

Input speed
Velocità in entrata
Eintriebsdrehzahl
Vitesse en entrée
Velocidad de entrada

Gear size
Grandezza riduttore
Getriebegröße
Taille réducteur
Tamaño reductor

Motor power
Potenza motore
Motorleistung
Puissance moteur
Potencia motor

H62C

Cube gear 675Nm

Rating - Cast Iron
PARALLEL SHAFT GEARBOXES

QUICK SELECTION / Selezione veloce										input speed (n ₁) = 1400 min ⁻¹								
Output Speed n ₂ [min ⁻¹]	Ratio i	Motor power P _{1M} [kW]	Output torque M _{2M} [Nm]	Service factor f.s.	Nominal power P _{1R} [kW]	Nominal torque M _{2R} [Nm]	Available B5 motor flanges					Available B14 motor flanges				Output Shaft		
							-C	-D	-E	-F	-G	-R	-T	-U	-V			Ratio code
213	6.57	7.5	312	1.2	8.8	380	B										3018	01
185	7.56	7.5	358	1.1	7.9	390	B										3016	02
159	8.82	7.5	419	1.0	7.1	410	B										3014	03
113	12.39	7.5	588	1.0	7.2	580	B										2018	04

C Ratio
Rapporto
Untersetzung
Rapport de réduction
Relación

Transmitted torque
Momento torcente trasmesso
Mögliche Drehmomente
Couple de sortie
Par transmitido

Service factor
Fattore di servizio
Betriebsfaktor
Facteur de service
Factor de servicio

Output shaft diam.
Diam. albero uscita
Durchmesser abtriebswelle
Diametre arbre lent
Diametro eje de salida

Notes
Note
Anmerkungen
Note
Notas

Type of load and starts per hour Tipo di carico e avviamenti per ora		Oper. hours per day Ore di funz. giorn.		
		3 h	10 h	24 h
Continuous or intermittent appl. with start / hour Applicazione cont. o interm. con n.ro operazioni/ora	Uniform / Uniforme	0.8	1	1.25
	Moderate / Moderato	1	1.25	1.5
	Heavy / Forte	1.25	1.5	1.75
Intermittent application with start / hour Applicazione intermittente con n.ro operazioni/ora	Uniform / Uniforme	1	1.25	1.5
	Moderate / Moderato	1.25	1.5	1.75
	Heavy / Forte	1.5	1.75	2.15

D	Motor flange available Flange disponibili Erhältliche Motorflansche Brides disponibles Bridas disponibles
B)	Mounting with reduction ring Montaggio con boccia di riduzione Reduzierhülsen Montage avec douille de réduction Montaje con casquillo de reducción
C)	Motor flangeholes position/terminal box position Posizione fori flangia/basetta motore Bohrungsposition am Motorflansch/-socket Position trous bride/barrette à bornes moteur Posición agujeros brida / base motor
B)	Available without reduction bushes Disponibile anche senza boccia Auch ohne Reduzierbuchse verfügbar Disponible aussi sans douille de réduction Disponible también sin casquillo

A	Select required torque (according to service factor)	Seleziona la coppia desiderata (comprensiva del fattore di servizio)	Max. Drehmoment in Bezug zum Betriebsfaktor	Sélectionner le couple souhaité (comprenant le facteur de service)	Seleccionar el par deseado (incluyendo el factor de servicio)
B	Select output speed	Seleziona la velocità in uscita	Ausgewählte Abtriebsdrehzahl	Sélectionner la vitesse de sortie	Seleccionar la velocidad de salida
C	On the same line of selected geared motor, you can find the gear ratio	Sulla riga corrispondente alla motorizzazione prescelta si può rilevare il rapporto di riduzione	Auf der gleichen Linie wie die ausgewählte Motorleistung steht auch die Getriebeuntersetzung	Sur la ligne correspondante à la motorisation pré-choisie on peut relever le rapport de réduction	En la línea correspondiente al motor preseleccionado es posible encontrar la relación de reducción
D	Select motor flange available (if requested)	Scegli la flangia disponibile (se richiesta)	Erhältliche Motorflansche (auf Anfrage)	Choisir la bride disponible (si elle est demandée)	Seleccionar la brida disponible (sobre pedido)



▪ **QUICK SELECTION** / Selezione veloce

input speed (n_1) = 1400 min⁻¹

Output Speed n_2 [min ⁻¹]	Ratio i	Motor power P_{1M} [kW]	Output torque M_{2M} [Nm]	Service factor f.s.	Nominal power P_{1R} [kW]	Nominal torque M_{2R} [Nm]	Available B5 motor flanges		B14 motor flanges				Output Shaft	Ratios code	
							-G	132	-	-	-	-			-
507	2.76	9	166	1.6	14.4	265			not available				2980	standard	01
395	3.54	9	213	1.3	11.6	275							2485	ø35	02
277	5.06	9	304	1.0	8.6	290							1891		03
241	5.81	7.5	281	1.2	8.5	330							1693	ø40	04
206	6.79	7.5	329	1.2	8.4	380							1495	On request	05

The dynamic efficiency is **0.98** for all ratios

A) Motor Flanges Available
Flange Motore Disponibili

B) Supplied with Reduction Bushing
Fornito con Bussola di Riduzione

B) Available on Request without reduction bushing
Disponibile a Richiesta senza Bussola di Riduzione

C) Motor Flange Holes Position
Posizione Fori Flangia Motore

EN Unit **H61C** is supplied with synthetic oil for lifetime lubrication, no maintenance is necessary. See table 1 for lubrication and recommended quantity. In table 2 please see possible radial loads and axial loads on the gearbox.

I Il riduttore **H61C** viene fornito completo di olio sintetico per la lubrificazione permanente e non necessita di alcuna manutenzione. Vedi tab.1 per oli e quantità consigliati. In tab.2 sono presenti i carichi radiali e assiali applicabili al riduttore.

D Das Getriebe **H61C** ist mit synthetischem Öl gefüllt und ist lebensdauergeschmiert. In Tabelle 1 ist die Schmiermenge und das empfohlene Schmiermittel angegeben. In Tabelle 2 sind die zulässigen Radial - und Axialbelastungen des Getriebes aufgeführt.

F Le réducteur **H61C** est fourni complet avec de l'huile synthétique pour la lubrification permanente et ne nécessite aucun entretien. Voir tableau 1 concernant les huiles et les quantités conseillées. Les charges radiales et axiales applicables au réducteur sont précisées dans le tableau 2.

E El reductor tamaño **H61C** se suministra, lubricado de por vida con aceite sintético y no requieren mantenimiento alguna. Ver tabla 1, para cantidades y aceites recomendados. En la tabla 2, se encuentran las cargas radiales y axiales admitidas por el reductor.

Standard supplied	For these mounting position specify in the order or add oil Per queste posizioni specificare in fase d'ordine o aggiungere olio						
B3	B6	B7	B8	V5	V6	V8	
2.25 LT	3.20 LT	3.00 LT	2.25 LT	4.35 LT	2.35 LT	Ask	
SHELL Omala S4 WE 320				ENI Telium VSF 320			

For all details on lubrication and plugs check our website **tab. 1**
Per maggiori dettagli su lubrificazione e tappi olio vedi il nostro sito web

RADIAL AND AXIAL LOADS

Output shaft
Albero di uscita

$F_{eq} = F_R \cdot \frac{149.5}{X+119.5}$

n_2	FA	FR	n_2	FA	FR	n_2	FA	FR
300	600	3000	140	720	3600	70	940	4700
250	640	3200	120	740	3700	40	1220	6100
200	690	3460	85	860	4300	15	1300	6500

On request reinforced bearings to increase loads.
A richiesta cuscinetti rinforzati per aumentare i carichi.

tab. 2

PH61C... Basic gearbox
Riduttore base

Gearbox weight
peso riduttore **40.0 kg**

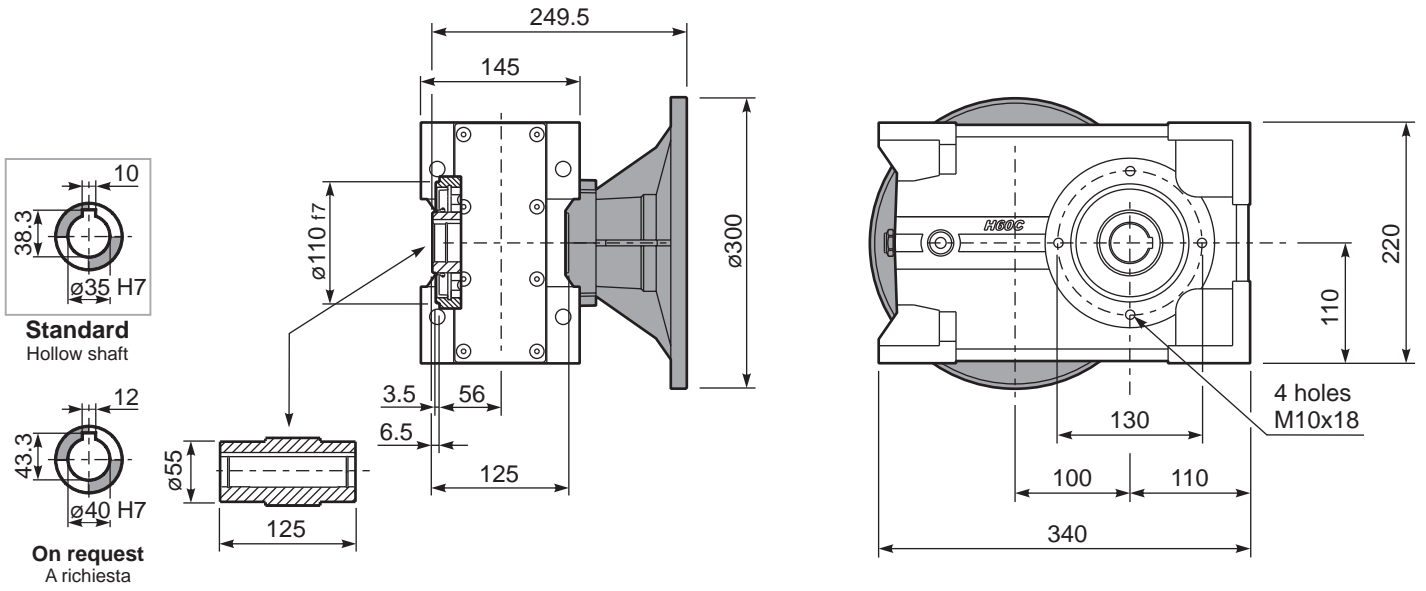

PH61C...-N Feet
Piedini

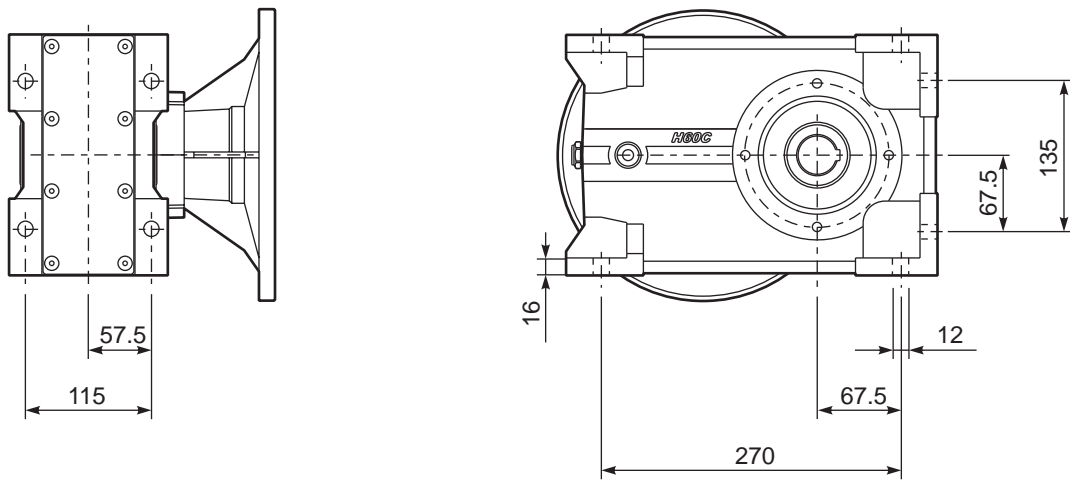

PH61C...-F Output flange
Flangia uscita

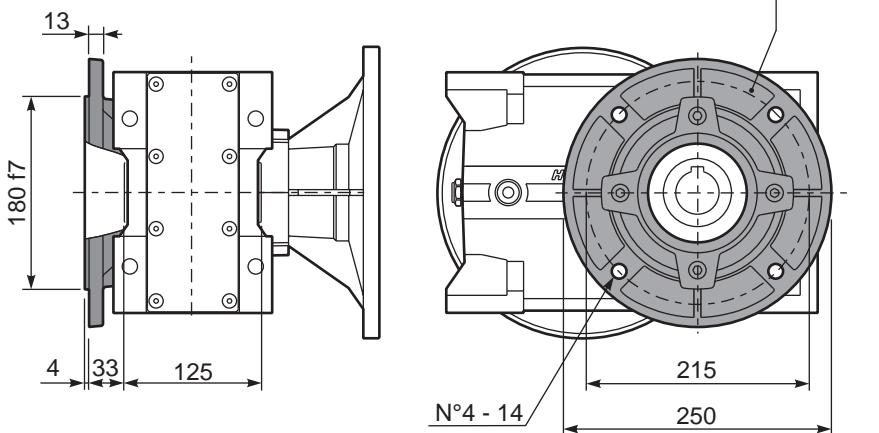

PH61C A... Single output shaft
Albero uscita semplice

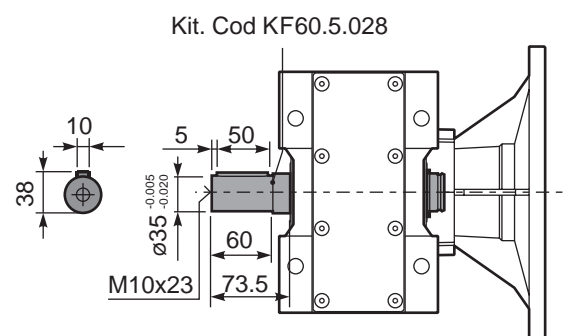



■ **QUICK SELECTION** / Selezione veloce

input speed (n_1) = 1400 min⁻¹

Output Speed n_2 [min ⁻¹]	Ratio i	Motor power P_{1M} [kW]	Output torque M_{2M} [Nm]	Service factor f.s.	Nominal power P_{1R} [kW]	Nominal torque M_{2R} [Nm]	Available B5 motor flanges					Available B14 motor flanges				Output Shaft 	Ratios code
							-C	-D	-E	-F	-G	-R	-T	-U	-V		
							71	80	90	100 112	132	80	90	100 112	132		
213	6.57	7.5	312	1.2	8.8	380	B									3018	01
185	7.56	7.5	358	1.1	7.9	390	B									3016	02
159	8.82	7.5	419	1.0	7.1	410	B									3014	03
113	12.39	7.5	588	1.0	7.2	580	B									2018	04
98	14.24	5.5	499	1.2	6.4	600	B									2016	05
84	16.75	5.5	587	1.1	6.1	665	B									1618	06
73	19.25	5.5	675	1.0	5.4	675	B									1616	07
64	21.78	4	558	1.2	4.7	675	B									1318	08
56	25.04	4	642	1.1	4.1	675	B									1316	09
47.9	29.23	4	750	0.9	3.5	675	B									1314	10
45.7	30.65	3	592	1.1	3.4	675	B									1116	11
39.1	35.78	3	691	1.0	2.9	675	B									1114	12
36.3	38.55	2.2	548	1.1	2.3	580	B									818	13
31.6	44.32	2.2	630	1.1	2.3	665	B									816	14
27.1	51.74	2.2	735	0.9	2.0	675	B									814	15
22.9	61.03	1.1	437	1.1	1.2	480	B									616	16
19.6	71.25	1.1	510	1.1	1.2	560	B									614	17

The dynamic efficiency is **0.96** for all ratios

A Motor Flanges Available
Flange Motore Disponibili

B Supplied with Reduction Bushing
Fornito con Bussola di Riduzione

B Available on Request without reduction bushing
Disponibile a Richiesta senza Bussola di Riduzione

C Motor Flange Holes Position
Posizione Fori Flangia Motore

EN Unit **H62C** is supplied with synthetic oil for lifetime lubrication, no maintenance is necessary. See table 1 for lubrication and recommended quantity. In table 2 please see possible radial loads and axial loads on the gearbox.

I Il riduttore **H62C** viene fornito completo di olio sintetico per la lubrificazione permanente e non necessita di alcuna manutenzione. Vedi tab.1 per oli e quantità consigliati. In tab.2 sono presenti i carichi radiali e assiali applicabili al riduttore.

D Das Getriebe **H62C** ist mit synthetischem Öl gefüllt und ist lebensdauergeschmiert. In Tabelle 1 ist die Schmiermenge und das empfohlene Schmiermittel angegeben. In Tabelle 2 sind die zulässigen Radial - und Axialbelastungen des Getriebes aufgeführt.

F Le réducteur **H62C** est fourni complet avec de l'huile synthétique pour la lubrification permanente et ne nécessite aucun entretien. Voir tableau 1 concernant les huiles et les quantités conseillées. Les charges radiales et axiales applicables au réducteur sont précisées dans le tableau 2.

E El reductor tamaño **H62C** se suministra, lubricado de por vida con aceite sintético y no requieren mantenimiento alguna. Ver tabla 1, para cantidades y aceites recomendados. En la tabla 2, se encuentran las cargas radiales y axiales admitidas por el reductor.

Standard supplied	For these mounting position specify in the order or add oil Per queste posizioni specificare in fase d'ordine o aggiungere olio						
B3	B6	B7	B8	V5	V6	V8	
2.25 LT	3.20 LT	3.00 LT	2.25 LT	4.35 LT	2.35 LT	Ask	
SHELL Omala S4 WE 320				ENI Telium VSF 320			

For all details on lubrication and plugs check our website
Per maggiori dettagli su lubrificazione e tappi olio vedi il nostro sito web **tab. 1**

RADIAL AND AXIAL LOADS

Output shaft
Albero di uscita

$F_{eq} = F_R \cdot \frac{149.5}{X+119.5}$

n_2	FA	FR	n_2	FA	FR	n_2	FA	FR
300	600	3000	140	720	3600	70	940	4700
250	640	3200	120	740	3700	40	1220	6100
200	690	3460	85	860	4300	15	1300	6500

On request reinforced bearings to increase loads.
A richiesta cuscinetti rinforzati per aumentare i carichi.

Input shaft
Albero in entrata

n_1	FA	FR
1400	450	2250
900	500	2500
500	600	3000

tab. 2

PH62C... Basic gearbox
Riduttore base

M. flanges	Kit code	øF	A
71B5	K023.4.041	160	227
80/90B5	K023.4.042	200	229
100/112B5	K023.4.043	250	238
132B5	KC51.4.043	300	259
80B14	K085.4.046	120	229
90B14	K085.4.045	140	229
100/112B14	K085.4.047	160	238
132B14	KC51.4.041	200	259

Standard
Hollow shaft

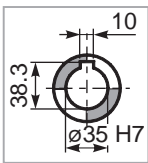

On request
A richiesta

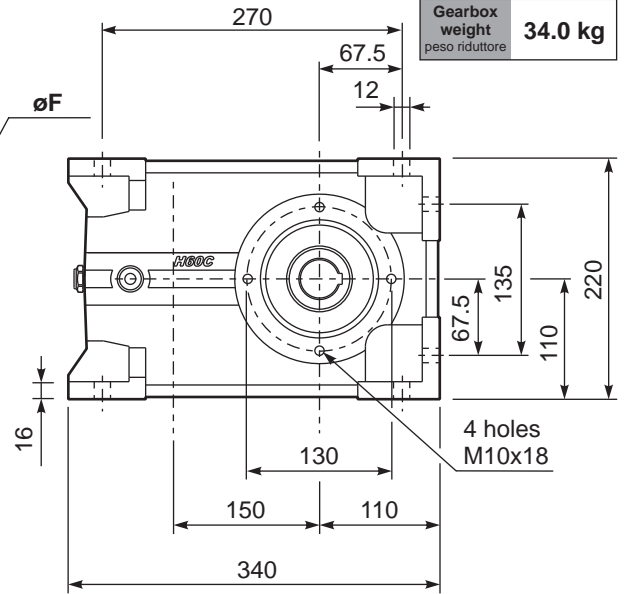
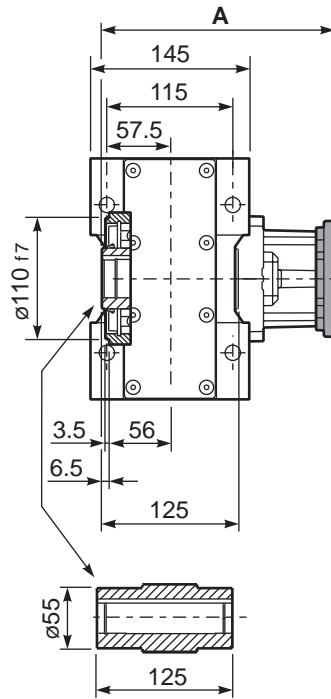
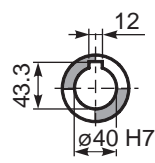

Gearbox weight
peso riduttore **34.0 kg**

PH62C...-F Output flange
Flangia uscita

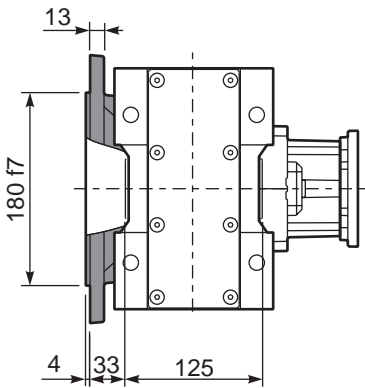

Kit. Cod KF60.9.011

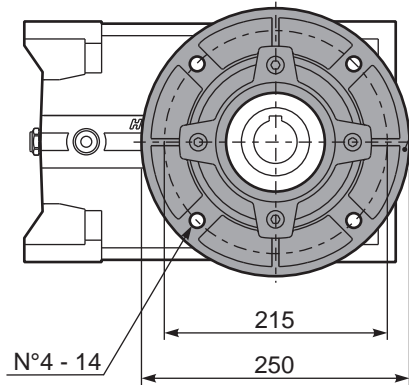

PH62C D... Shrink disk
Calettatore

Kit. Cod KF60.0.210LM

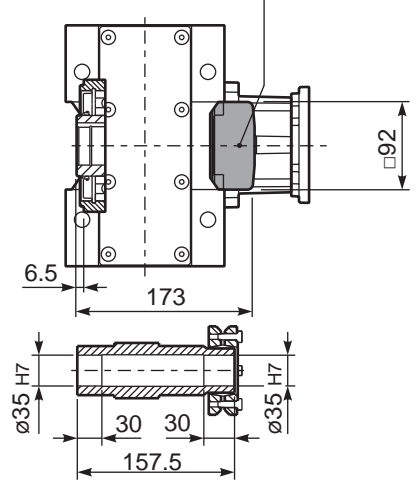

RH62C... Input Shaft
Albero in entrata

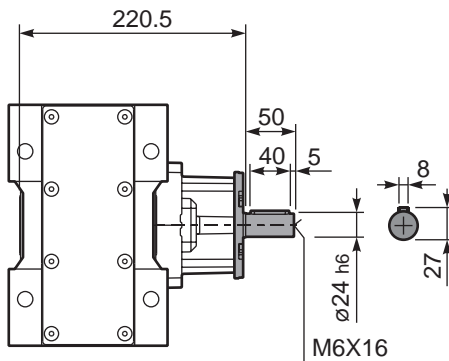

PH62C A... Single output shaft
Albero uscita semplice

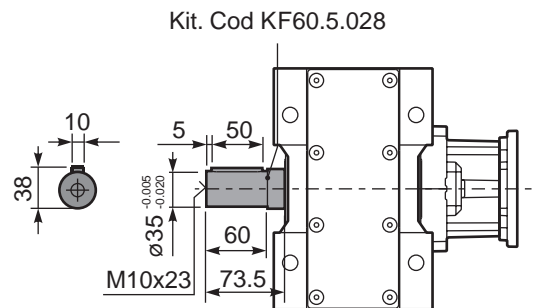

Kit. Cod KF60.5.028



QUICK SELECTION / Selezione veloce

input speed (n_1) = 1400 min⁻¹

Output Speed n_2 [min ⁻¹]	Ratio i	Motor power P_{1M} [kW]	Output torque M_{2M} [Nm]	Service factor f.s.	Nominal power P_{1R} [kW]	Nominal torque M_{2R} [Nm]	Available B5 motor flanges				Available B14 motor flanges			Output Shaft 	Ratios code
							-B	-C	-D	-E	-Q	-R	-T		
							63	71	80	90	71	80	90		
22.6	61.89	1.5	594	1.1	1.7	675	B				C	C		191318	01
19.7	71.16	1.5	683	1.0	1.5	675	B				C	C		191316	02
17.0	82.48	1.5	792	0.9	1.3	675	B				C	C		171316	03
14.5	96.29	1.1	675	1.0	1.1	675	B				C	C		171314	04
13.9	100.51	1.1	705	1.0	1.0	675	B				C	C		131318	05
12.1	115.56	0.75	556	1.2	0.91	675	B				C	C		131316	06
11.1	125.96	0.75	606	1.1	0.82	665	B				C	C		190816	07
10.4	134.91	0.75	649	1.0	0.78	675	B				C	C		131314	08
9.5	147.05	0.75	707	1.0	0.72	675	B				C	C		190814	09
8.2	170.44	0.55	605	1.1	0.62	675	B				C	C		170814	10
7.6	184.15	0.55	653	1.0	0.57	675	B				C	C		101314	11
6.8	205.87	0.55	730	0.9	0.51	675	B				C	C		91316	12
5.8	240.34	0.37	570	1.2	0.44	675	B				C	C		91314	13
5.0	279.22	0.37	662	1.0	0.37	665	B				C	C		100816	14
4.3	325.97	0.37	773	0.9	0.32	675	B				C	C		100814	15
3.8	364.41	0.25	583	1.1	0.28	665	B				C	C		90816	16
3.3	425.43	0.25	681	1.0	0.25	675	B				C	C		90814	17
2.9	481.19	0.18	589	1.1	0.22	665	B				C	C		70816	18
2.5	561.76	0.18	687	1.0	0.19	675	B				C	C		70814	19

The dynamic efficiency is **0.94** for all ratios

Motor Flanges Available
Flange Motore Disponibili

Supplied with Reduction Bushing
Fornito con Bussola di Riduzione

Available on Request without reduction bushing
Disponibile a Richiesta senza Bussola di Riduzione

Motor Flange Holes Position
Posizione Fori Flangia Motore

EN Unit **H63C** is supplied with synthetic oil for lifetime lubrication, no maintenance is necessary. See table 1 for lubrication and recommended quantity. In table 2 please see possible radial loads and axial loads on the gearbox.

I Il riduttore **H63C** viene fornito completo di olio sintetico per la lubrificazione permanente e non necessita di alcuna manutenzione. Vedi tab.1 per oli e quantità consigliati. In tab.2 sono presenti i carichi radiali e assiali applicabili al riduttore.

D Das Getriebe **H63C** ist mit synthetischem Öl gefüllt und ist lebensdauergeschmiert. In Tabelle 1 ist die Schmiermenge und das empfohlene Schmiermittel angegeben. In Tabelle 2 sind die zulässigen Radial - und Axialbelastungen des Getriebes aufgeführt.

F Le réducteur **H63C** est fourni complet avec de l'huile synthétique pour la lubrification permanente et ne nécessite aucun entretien. Voir tableau 1 concernant les huiles et les quantités conseillées. Les charges radiales et axiales applicables au réducteur sont précisées dans le tableau 2.

E El reductor tamaño **H63C** se suministra, lubricado de por vida con aceite sintético y no requieren mantenimiento alguna. Ver tabla 1, para cantidades y aceites recomendados. En la tabla 2, se encuentran las cargas radiales y axiales admitidas por el reductor.

Standard supplied	For these mounting position specify in the order or add oil Per queste posizioni specificare in fase d'ordine o aggiungere olio						
B3	B6	B7	B8	V5	V6	V8	
2.35 LT	3.85 LT	3.15 LT	2.35 LT	4.55 LT	2.50 LT	Ask	
SHELL Omala S4 WE 320				ENI Telium VSF 320			

For all details on lubrication and plugs check our website **tab. 1**
Per maggiori dettagli su lubrificazione e tappi olio vedi il nostro sito web

RADIAL AND AXIAL LOADS

Output shaft

Albero di uscita

$$F_{eq} = F_R \cdot \frac{149.5}{X + 119.5}$$



n_2	FA	FR	n_2	FA	FR	n_2	FA	FR
300	600	3000	140	720	3600	70	940	4700
250	640	3200	120	740	3700	40	1220	6100
200	690	3460	85	860	4300	15	1300	6500

On request reinforced bearings to increase loads.

A richiesta cuscinetti rinforzati per aumentare i carichi.

Input shaft

Albero in entrata

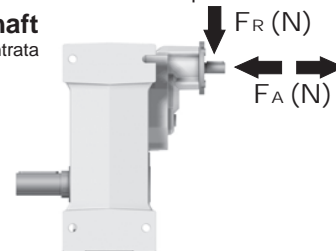

n_1	FA	FR
1400	240	1200
900	280	1400
500	340	1700

tab. 2

PH63C... Basic gearbox
Riduttore base

M. flanges	Kit code	øF	A
63B5	K063.4.041	140	239
71B5	K063.4.042	160	237
80/90B5	K063.4.043	200	239
71B14	K063.4.047	105	237
80B14	K063.4.046	120	239
90B14	K063.4.041	140	239

Standard
Hollow shaft

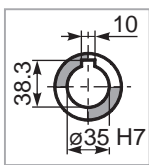

On request
A richiesta

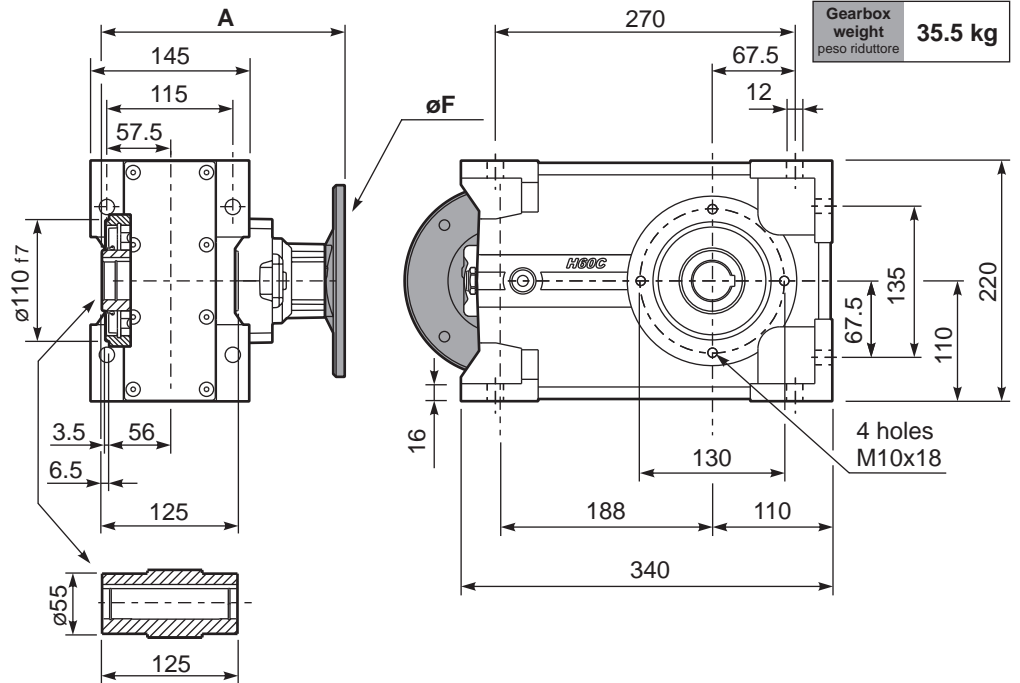
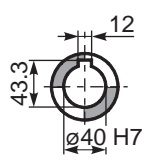

Gearbox weight
peso riduttore **35.5 kg**

PH63C...-F Output flange
Flangia uscita

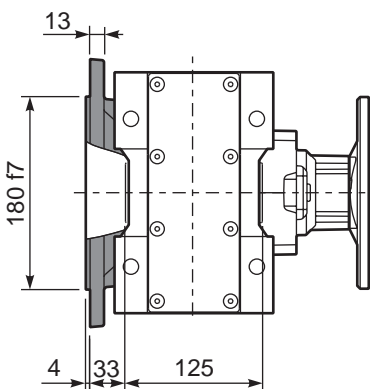

Kit. Cod KF60.9.011

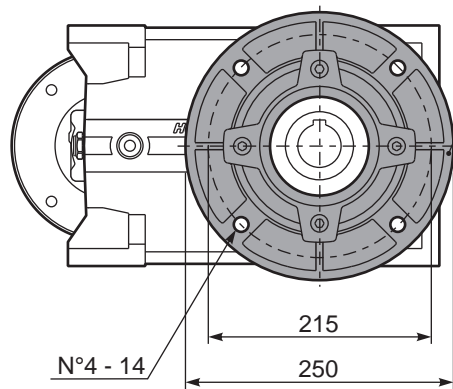

PH63C D... Shrink disk
Calettatore

Kit. Cod KF60.0.210LM

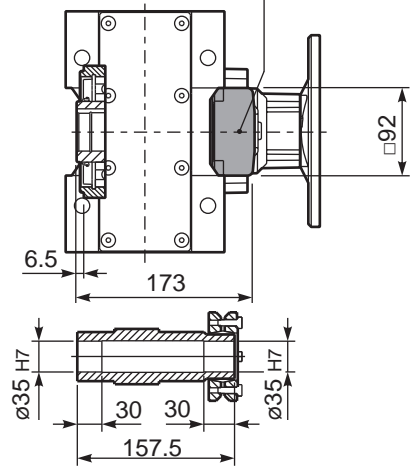

RH63C... Input Shaft
Albero in entrata

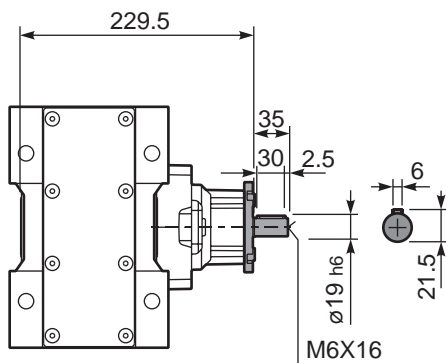

PH63C A... Single output shaft
Albero uscita semplice

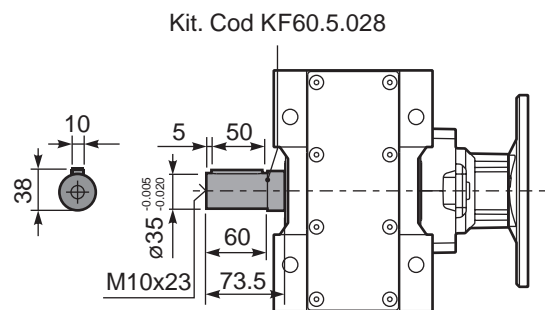

Kit. Cod KF60.5.028



▪ **QUICK SELECTION** / Selezione veloce

input speed (n_1) = 1400 min⁻¹

Output Speed n_2 [min ⁻¹]	Ratio i	Motor power P_{1M} [kW]	Output torque M_{2M} [Nm]	Service factor f.s.	Nominal power P_{1R} [kW]	Nominal torque M_{2R} [Nm]	Available B5 motor flanges		B14 motor flanges				Output Shaft 	Ratios code 	
							-G	132	-	-	-	-			-
227	6.17	9	371	1.2	10.9	450			not available				18111	standard ø40 ø45 On request	01
198	7.06	9	425	1.4	12.7	600							16113		02
170	8.21	9	494	1.4	12.2	670							14115		03

The dynamic efficiency is **0.98** for all ratios

A Motor Flanges Available
Flange Motore Disponibili

B) Supplied with Reduction Bushing
Fornito con Bussola di Riduzione

B) Available on Request without reduction bushing
Disponibile a Richiesta senza Bussola di Riduzione

C) Motor Flange Holes Position
Posizione Fori Flangia Motore

EN Unit **H71C** is supplied without lubricant and equipped with a breather, level and drain plugs. User can add mineral oil keeping existing plugs. Should the user wish to fill it with synthetic oil, it is recommended to replace the existing plugs with a closed plug.
See table 1 for lubrication and recommended quantity.
In table 2 please see possible radial loads and axial loads on the gearbox.

I Il riduttore tipo **H71C** è fornito privo di lubrificazione con tappi di sfiato, livello e scarico olio. L'utente può immettere olio minerale mantenendo i tappi esistenti. Se immetterà olio sintetico, dovrà sostituire i tappi esistenti con altri tipo chiuso.
Tab.1 per oli e quantità consigliati.
Tab.2 carichi radiali e assiali applicabili al riduttore.

D Das Getriebe der Baugröße **H71C** wird ohne Schmiermittel geliefert. Es ist jedoch mit Einfüllschraube, Überdruckventil und Ablassschraube ausgerüstet. Das benötigte mineralische Öl kann über die Einfüllschraube eingefüllt werden. Sollte synthetisches Öl bevorzugt werden, so ist sind das eingebaute Überdruckventil durch eine geschlossenen Schraube zu ersetzen.
In Tabelle 1 ist die Schmiermenge und das empfohlene Schmiermittel angegeben
In Tabelle 2 sind die zulässigen Radial - und Axialbelastungen des Getriebes aufgeführt.

F Le réducteur de type **H71C** est fourni sans lubrification et avec un bouchon de remplissage, de niveau et d'évacuation de l'huile. L'utilisateur peut y verser de l'huile minérale en conservant les bouchons existants. S'il y versera de l'huile synthétique, il devra substituer les bouchons existants avec d'autres bouchons de type fermé.
Voir tableau 1 concernant les huiles et les quantités conseillées.
Voir tableau 2 concernant les charges radiales et axiales applicables au réducteur

E El reductor tamaño **H71C** se suministra sin lubricante, provisto de tapones de respiración, nivel y descarga de aceite. El usuario puede utilizar aceite mineral, manteniendo los tapones existentes. Si prefiere utilizar aceite sintético deberá sustituir los tapones existentes por tapones ciegos. La prerreducción se suministra con tapones ciegos, lubricado de por vida con aceite sintético.
Ver tabla 1, para cantidades y aceites recomendados.
En la tabla 2, se encuentran las cargas radiales y axiales admitidas por el reductor.

B3	B6	B7	B8	V5	V6	V8
3.20 LT	4.65 LT	4.00 LT	3.20 LT	6.00 LT	3.10 LT	Ask
SHELL Omala S2 GX 460				ENI Blasia 460		

For all details on lubrication and plugs check our website **tab. 1**
Per maggiori dettagli su lubrificazione e tappi olio vedi il nostro sito web

RADIAL AND AXIAL LOADS

Output shaft
Albero di uscita

$F_{eq} = F_R \cdot \frac{174.5}{X+134.5}$

n_2	FA	FR	n_2	FA	FR	n_2	FA	FR
300	740	3700	140	860	4300	70	1020	5100
250	800	4000	120	900	4500	40	1300	6500
200	830	4150	85	970	4850	15	1700	8500

On request reinforced bearings to increase loads.
A richiesta cuscinetti rinforzati per aumentare i carichi.

tab. 2

PH71C... Basic gearbox
Riduttore base

Gearbox weight
peso riduttore **51.0 kg**

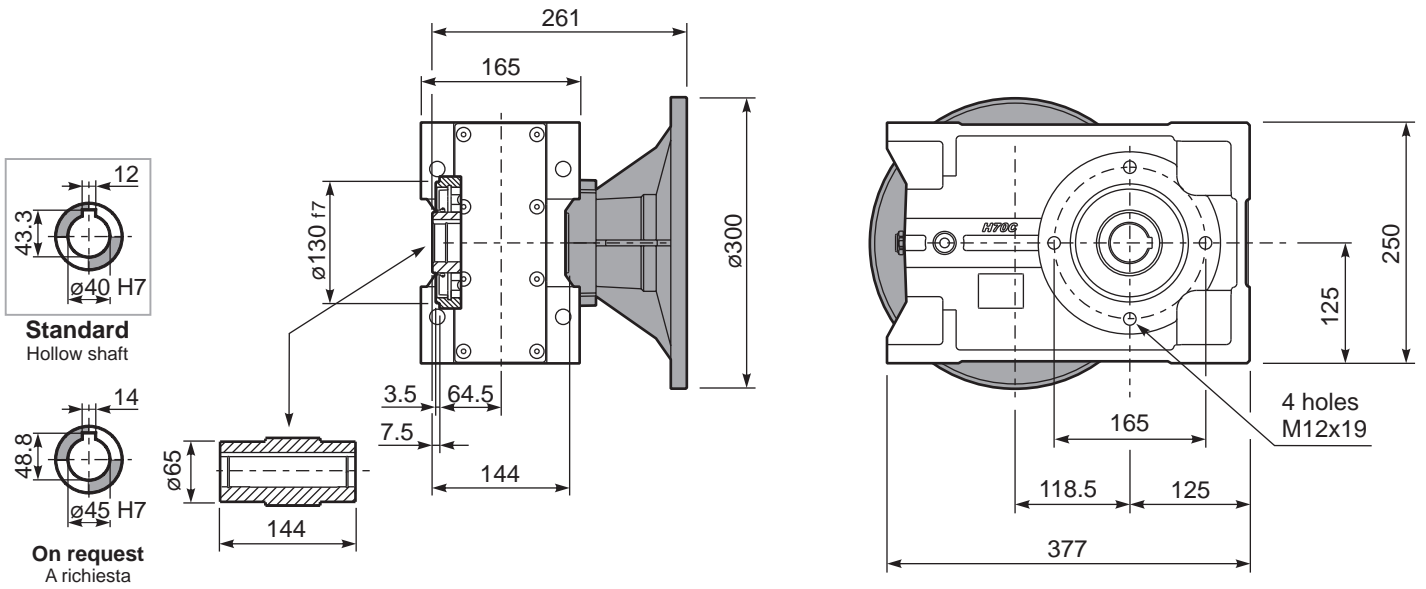

PH71C...-F Output flange
Flangia uscita

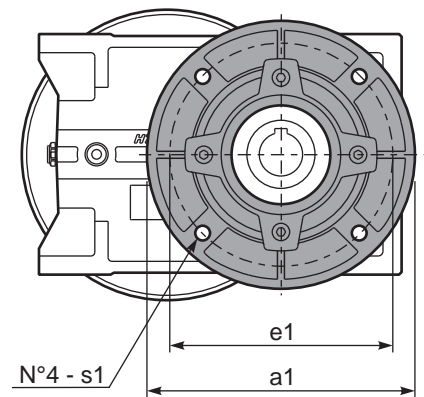
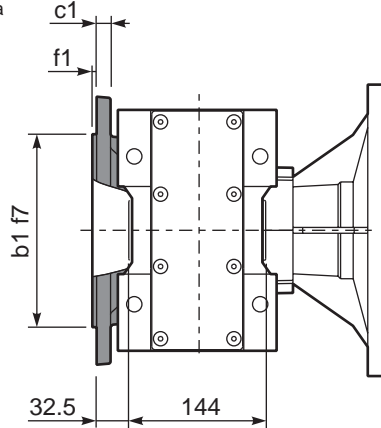

Available output flanges
Flange di uscita

a1 ø	b1	c1	e1	f1	s1	Kit code
250	180	13	215	3	14	KF70.9.011
300	230	16	265	4	14	KF70.9.012

PH71C...-N Feet
Piedini

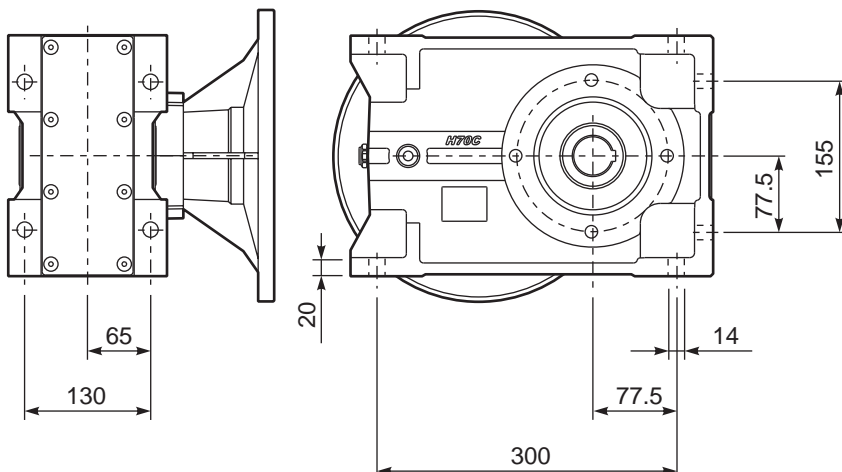

PH71C A... Single output shaft
Albero uscita semplice

Kit. Cod KF70.5.028

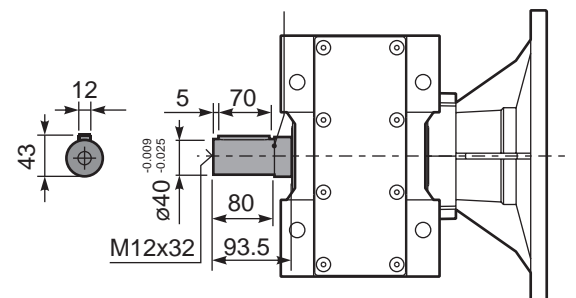



QUICK SELECTION / Selezione veloce

input speed (n_1) = 1400 min⁻¹

Output Speed n_2 [min ⁻¹]	Ratio i	Motor power P_{1M} [kW]	Output torque M_{2M} [Nm]	Service factor f.s.	Nominal power P_{1R} [kW]	Nominal torque M_{2R} [Nm]	Available B5 motor flanges					Available B14 motor flanges				Output Shaft 	Ratios code
							-C	-D	-E	-F	-G	-R	-T	-U	-V		
							71	80	90	100 112	132	80	90	100 112	132		
175	8.02	9	473	1.1	9.9	520	B									3018	01
152	9.18	9	541	1.1	9.8	590	B									3016	02
131	10.68	9	630	1.1	9.7	680	B									3014	03
93	15.11	7.5	717	1.1	7.8	775	B									2018	04
81	17.30	7.5	821	1.1	7.8	885	B									2016	05
70	20.13	7.5	955	0.9	6.8	900	B									2014	06
60	23.39	5.5	820	1.1	5.9	900	B									1616	07
51	27.21	5.5	954	0.9	5.1	900	B									1614	08
46.0	30.42	4	780	1.2	4.5	900	B									1316	09
39.6	35.38	4	907	1.0	3.9	900	B									1314	10
37.6	37.24	3	719	1.2	3.7	895	B									1116	11
32.3	43.31	3	836	1.1	3.2	900	B									1114	12
29.8	47.02	2.2	668	1.1	2.3	705	B									818	13
26.0	53.85	2.2	765	1.1	2.3	810	B									816	14
22.4	62.63	2.2	890	1.0	2.2	900	B									814	15
18.9	74.16	1.1	531	1.1	1.2	585	B									616	16
16.2	86.25	1.1	617	1.1	1.2	680	B									614	17

The dynamic efficiency is **0.96** for all ratios

- Motor Flanges Available** Flange Motore Disponibili
- B) Supplied with Reduction Bushing** Fornito con Bussola di Riduzione
- B) Available on Request without reduction bushing** Disponibile a Richiesta senza Bussola di Riduzione
- C) Motor Flange Holes Position** Posizione Fori Flangia Motore

EN Unit **H72C** is supplied without lubricant and equipped with a breather, level and drain plugs. User can add mineral oil keeping existing plugs. Should the user wish to fill it with synthetic oil, it is recommended to replace the existing plugs with a closed plug. See table 1 for lubrication and recommended quantity. In table 2 please see possible radial loads and axial loads on the gearbox.

I Il riduttore tipo **H72C** è fornito privo di lubrificazione con tappi di sfiato, livello e scarico olio. L'utente può immettere olio minerale mantenendo i tappi esistenti. Se immetterà olio sintetico, dovrà sostituire i tappi esistenti con altri tipo chiuso. Tab.1 per oli e quantità consigliati. Tab.2 carichi radiali e assiali applicabili al riduttore.

D Das Getriebe der Baugröße **H72C** wird ohne Schmiermittel geliefert. Es ist jedoch mit Einfüllschraube, Überdruckventil und Ablassschraube ausgerüstet. Das benötigte mineralische Öl kann über die Einfüllschraube eingefüllt werden. Sollte synthetisches Öl bevorzugt werden, so ist sind das eingebaute Überdruckventil durch eine geschlossenen Schraube zu ersetzen. In Tabelle 1 ist die Schmiermenge und das empfohlene Schmiermittel angegeben. In Tabelle 2 sind die zulässigen Radial - und Axialbelastungen des Getriebes aufgeführt.

F Le réducteur de type **H72C** est fourni sans lubrification et avec un bouchon de remplissage, de niveau et d'évacuation de l'huile. L'utilisateur peut y verser de l'huile minérale en conservant les bouchons existants. S'il y versera de l'huile synthétique, il devra substituer les bouchons existants avec d'autres bouchons de type fermé. Voir tableau 1 concernant les huiles et les quantités conseillées. Voir tableau 2 concernant les charges radiales et axiales applicables au réducteur.

E El reductor tamaño **H72C** se suministra sin lubricante, provisto de tapones de respiración, nivel y descarga de aceite. El usuario puede utilizar aceite mineral, manteniendo los tapones existentes. Si prefiere utilizar aceite sintético deberá sustituir los tapones existentes por tapones ciegos. La prerreducción se suministra con tapones ciegos, lubricado de por vida con aceite sintético. Ver tabla 1, para cantidades y aceites recomendados. En la tabla 2, se encuentran las cargas radiales y axiales admitidas por el reductor.

B3	B6	B7	B8	V5	V6	V8
3.20 LT	4.65 LT	4.00 LT	3.20 LT	6.20 LT	3.10 LT	Ask
SHELL Omala S2 GX 460				ENI Blasias 460		

For all details on lubrication and plugs check our website **tab. 1**
Per maggiori dettagli su lubrificazione e tappi olio vedi il nostro sito web

RADIAL AND AXIAL LOADS

Output shaft
Albero di uscita

$F_{eq} = F_R \cdot \frac{174.5}{X+134.5}$

n_2	FA	FR	n_2	FA	FR	n_2	FA	FR
300	740	3700	140	860	4300	70	1020	5100
250	800	4000	120	900	4500	40	1300	6500
200	830	4150	85	970	4850	15	1700	8500

On request reinforced bearings to increase loads.
A richiesta cuscinetti rinforzati per aumentare i carichi.

Input shaft
Albero in entrata

n_1	FA	FR
1400	450	2250
900	500	2500
500	600	3000

tab. 2

PH72C... Basic gearbox
Riduttore base

M. flanges	Kit code	øF	A
71B5	K023.4.041	160	238.5
80/90B5	K023.4.042	200	240.5
100/112B5	K023.4.043	250	249.5
132B5	KC51.4.043	300	270.5
<hr/>			
80B14	K085.4.046	120	240.5
90B14	K085.4.045	140	240.5
100/112B14	K085.4.047	160	249.5
132B14	KC51.4.041	200	270.5

Gearbox weight
peso riduttore **46.0 kg**

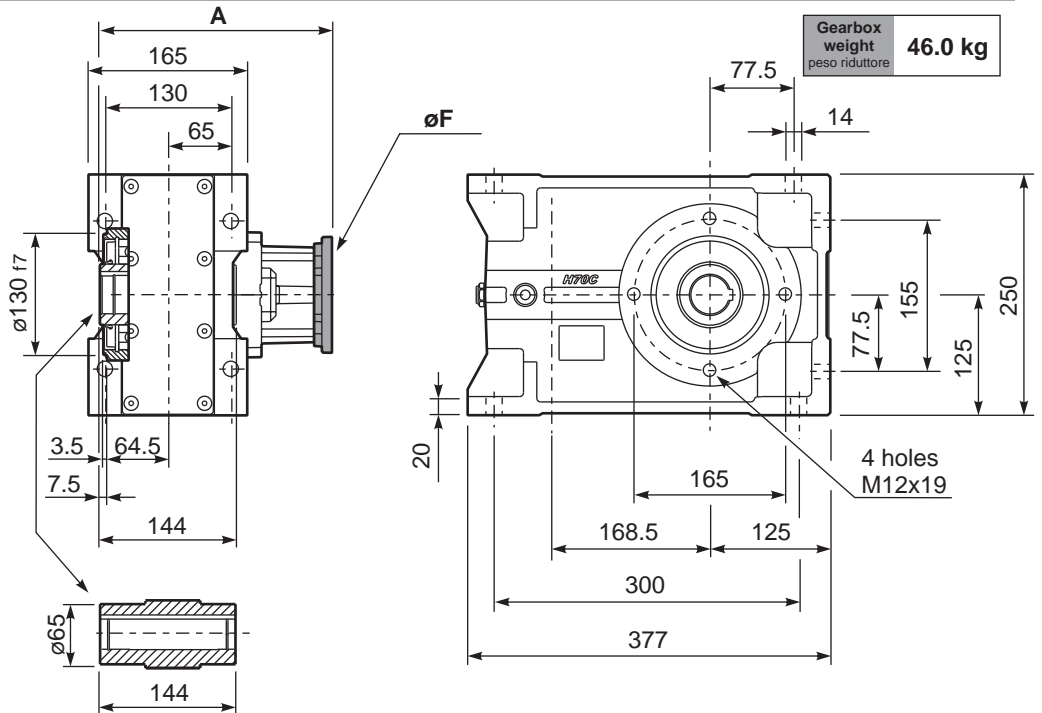

Standard
Hollow shaft

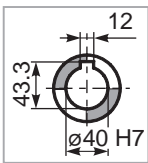

On request
A richiesta

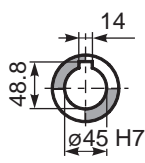

PH72C...-F Output flange
Flangia uscita

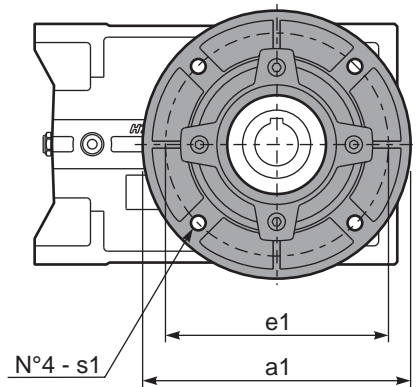
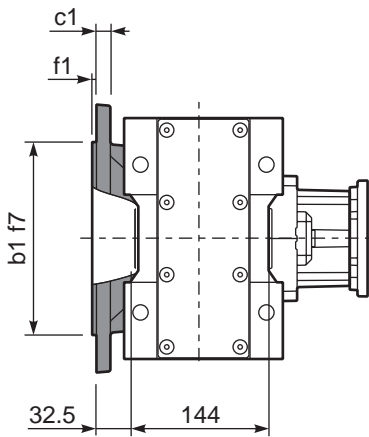

Available output flanges

Flange di uscita

a1 ø	b1	c1	e1	f1	s1	Kit code
250	180	13	215	3	14	KF70.9.011
300	230	16	265	4	14	KF70.9.012

PH72C D... Shrink disk
Calettatore

Kit. Cod KF70.0.210LM

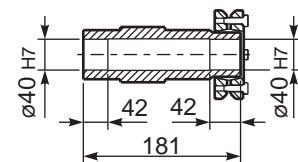
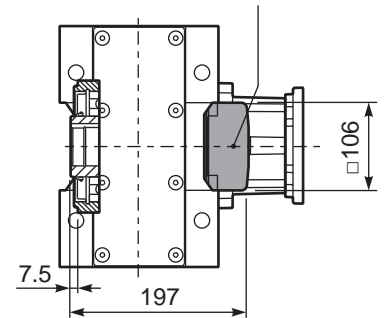

RH72C... Input Shaft
Albero in entrata

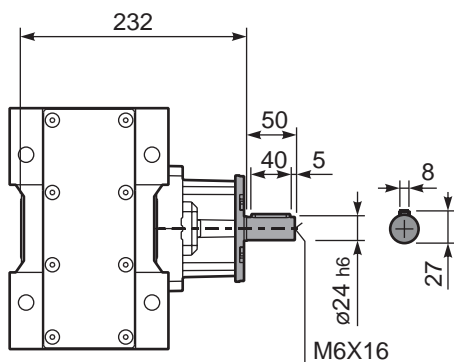

PH72C A... Single output shaft
Albero uscita semplice

Kit. Cod KF70.5.028

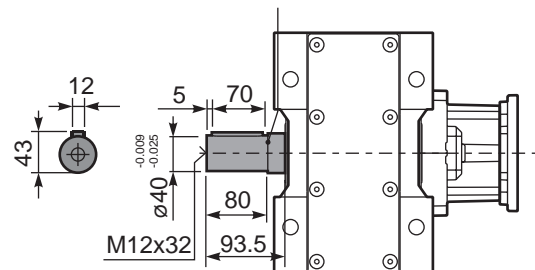

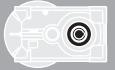

QUICK SELECTION / Selezione veloce

input speed (n_1) = 1400 min⁻¹

Output Speed n_2 [min ⁻¹]	Ratio i	Motor power P_{1M} [kW]	Output torque M_{2M} [Nm]	Service factor f.s.	Nominal power P_{1R} [kW]	Nominal torque M_{2R} [Nm]	Available B5 motor flanges				Available B14 motor flanges			Output Shaft 	Ratios code
							-B	-C	-D	-E	-Q	-R	-T		
							63	71	80	90	71	80	90		
18.5	75.50	1.5	725	1.1	1.7	825	B				C	C		191318	01
16.2	86.47	1.5	830	1.1	1.6	900	B				C	C		191316	02
14.0	100.22	1.5	962	0.9	1.4	900	B				C	C		171316	03
12.0	116.56	1.1	817	1.1	1.2	900	B				C	C		171314	04
10.2	136.82	1.1	959	0.9	1.0	900	B				C	C		151314	05
9.1	153.05	0.75	736	1.1	0.83	810	B				C	C		190816	06
8.6	163.31	0.75	785	1.1	0.86	900	B				C	C		131314	07
7.9	178.01	0.75	856	1.1	0.79	900	B				C	C		190814	08
7.3	191.67	0.75	922	1.0	0.73	900	B				C	C		101316	09
6.8	206.32	0.75	992	0.9	0.68	900	B				C	C		170814	10
6.3	222.92	0.55	791	1.1	0.63	900	B				C	C		101314	11
5.8	242.18	0.55	859	1.0	0.58	900	B				C	C		150814	12
5.6	250.15	0.55	888	1.0	0.56	900	B				C	C		91316	13
4.8	289.08	0.55	1026	0.9	0.49	900	B				C	C		130814	14
4.2	330.31	0.37	783	1.1	0.42	890	B				C	C		71316	15
3.5	394.59	0.37	936	1.0	0.36	900	B				C	C		100814	16
2.7	514.99	0.25	824	1.1	0.27	900	B				C	C		90814	17
2.1	680.03	0.18	832	1.1	0.21	900	B				C	C		70814	18

The dynamic efficiency is **0.94** for all ratios

Motor Flanges Available
Flange Motore Disponibili

B) Supplied with Reduction Bushing
Fornito con Bussola di Riduzione

B) Available on Request without reduction bushing
Disponibile a Richiesta senza Bussola di Riduzione

C) Motor Flange Holes Position
Posizione Fori Flangia Motore

EN Unit **H73C** is supplied without lubricant and equipped with a breather, level and drain plugs. User can add mineral oil keeping existing plugs. Should the user wish to fill it with synthetic oil, it is recommended to replace the existing plugs with a closed plug.
See table 1 for lubrication and recommended quantity. In table 2 please see possible radial loads and axial loads on the gearbox.

I Il riduttore tipo **H73C** è fornito privo di lubrificazione con tappi di sfiato, livello e scarico olio. L'utente può immettere olio minerale mantenendo i tappi esistenti. Se immetterà olio sintetico, dovrà sostituire i tappi esistenti con altri tipo chiuso.
Tab.1 per oli e quantità consigliati.
Tab.2 carichi radiali e assiali applicabili al riduttore.

D Das Getriebe der Baugröße **H73C** wird ohne Schmiermittel geliefert. Es ist jedoch mit Einfüllschraube, Überdruckventil und Ablassschraube ausgerüstet. Das benötigte mineralische Öl kann über die Einfüllschraube eingefüllt werden. Sollte synthetisches Öl bevorzugt werden, so ist sind das eingebaute Überdruckventil durch eine geschlossenen Schraube zu ersetzen.
In Tabelle 1 ist die Schmiermenge und das empfohlene Schmiermittel angegeben
In Tabelle 2 sind die zulässigen Radial - und Axialbelastungen des Getriebes aufgeführt.

F Le réducteur de type **H73C** est fourni sans lubrification et avec un bouchon de remplissage, de niveau et d'évacuation de l'huile. L'utilisateur peut y verser de l'huile minérale en conservant les bouchons existants. S'il y versera de l'huile synthétique, il devra substituer les bouchons existants avec d'autres bouchons de type fermé.
Voir tableau 1 concernant les huiles et les quantités conseillées.
Voir tableau 2 concernant les charges radiales et axiales applicables au réducteur

E El reductor tamaño **H73C** se suministra sin lubricante, provisto de tapones de respiración, nivel y descarga de aceite. El usuario puede utilizar aceite mineral, manteniendo los tapones existentes. Si prefiere utilizar aceite sintético deberá sustituir los tapones existentes por tapones ciegos. La prerreducción se suministra con tapones ciegos, lubricado de por vida con aceite sintético.
Ver tabla 1, para cantidades y aceites recomendados.
En la tabla 2, se encuentran las cargas radiales y axiales admitidas por el reductor.

B3	B6	B7	B8	V5	V6	V8
3.30 LT	5.70 LT	4.15 LT	3.30 LT	6.40 LT	3.25 LT	Ask
SHELL Omala S2 GX 460				ENI Blasias 460		

For all details on lubrication and plugs check our website **tab. 1**
Per maggiori dettagli su lubrificazione e tappi olio vedi il nostro sito web

RADIAL AND AXIAL LOADS

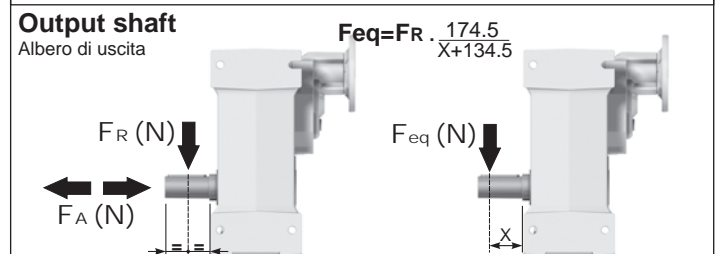

n_2	FA	FR	n_2	FA	FR	n_2	FA	FR
300	740	3700	140	860	4300	70	1020	5100
250	800	4000	120	900	4500	40	1300	6500
200	830	4150	85	970	4850	15	1700	8500

On request reinforced bearings to increase loads.

A richiesta cuscinetti rinforzati per aumentare i carichi.

Input shaft Albero in entrata	n_1	FA	FR
	1400	400	2000
	900	440	2200
	500	440	2200

tab. 2

PH73C... Basic gearbox
Riduttore base

M. flanges	Kit code	øF	A
63B5	K063.4.041	140	250.5
71B5	K063.4.042	160	248.5
80/90B5	K063.4.043	200	250.5
71B14	K063.4.047	105	248.5
80B14	K063.4.046	120	250.5
90B14	K063.4.041	140	250.5

Standard
Hollow shaft

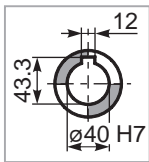

On request
A richiesta

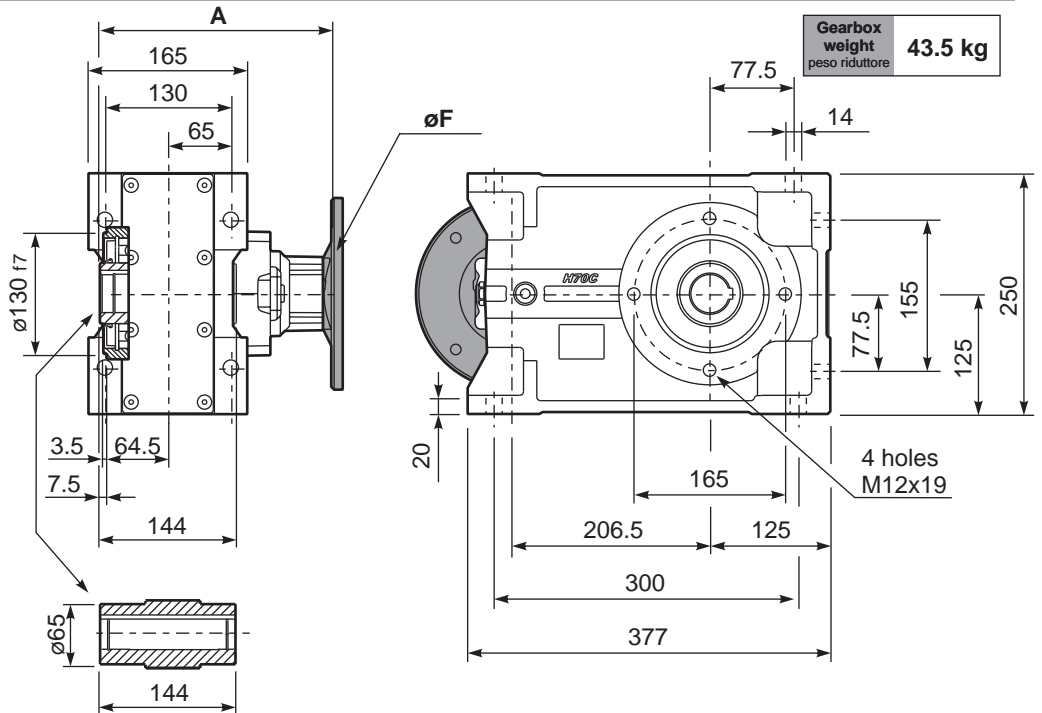
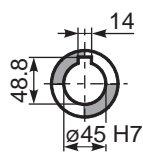

PH73C...-F Output flange
Flangia uscita

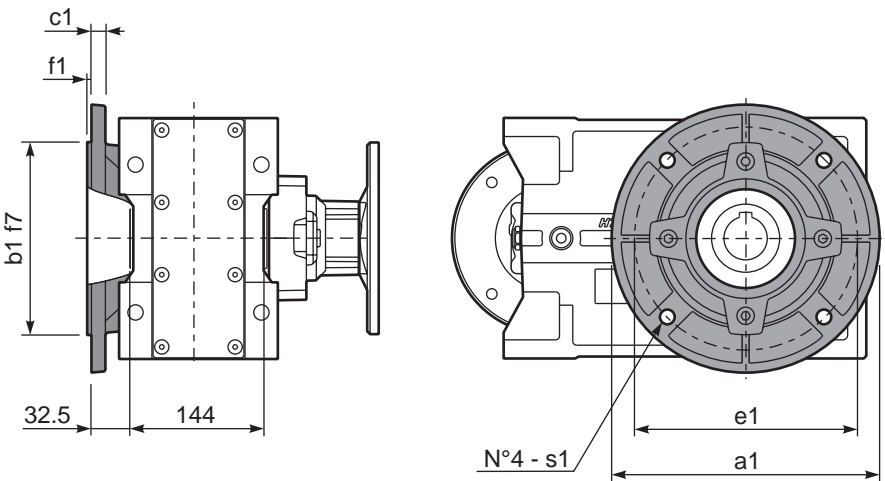

Available output flanges
Flange di uscita

a1 ø	b1	c1	e1	f1	s1	Kit code
250	180	13	215	3	14	KF70.9.011
300	230	16	265	4	14	KF70.9.012

PH73C D... Shrink disk
Calettatore

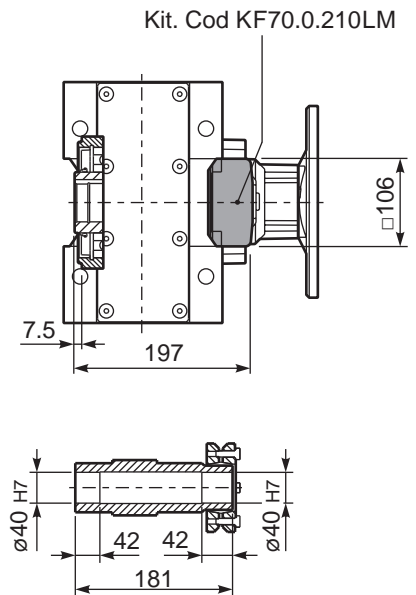

RH73C... Input Shaft
Albero in entrata

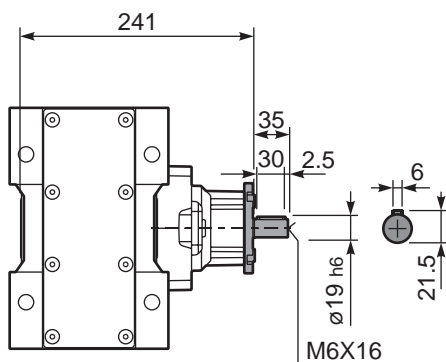

PH73C A... Single output shaft
Albero uscita semplice

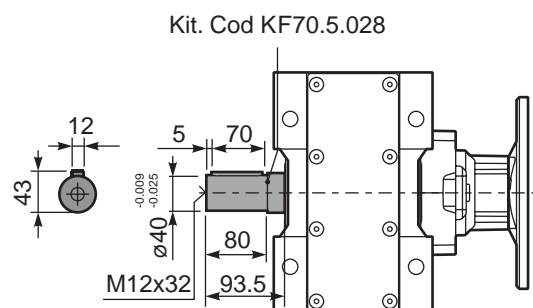



■ **QUICK SELECTION** / Selezione veloce

input speed (n_1) = 1400 min⁻¹

Output Speed n_2 [min ⁻¹]	Ratio i	Motor power P_{1M} [kW]	Output torque M_{2M} [Nm]	Service factor f.s.	Nominal power P_{1R} [kW]	Nominal torque M_{2R} [Nm]	Available B5 motor flanges		B14 motor flanges				Output Shaft	Ratios code	
							-H	-I	-	-	-	-			-
528	2.65	22	374	1.7	36.7	650			not available				2361	standard	01
409	3.42	22	483	1.6	32.8	750			not available				1965	ø50	02
304	4.60	22	649	1.5	30.9	950			not available				1569		03
256	5.46	22	771	1.3	27.4	1000			not available				1371	ø55	04
211	6.64	22	937	1.3	26.5	1175			not available				1173	On request	05

The dynamic efficiency is **0.98** for all ratios

A) Motor Flanges Available
Flange Motore Disponibili

B) Supplied with Reduction Bushing
Fornito con Bussola di Riduzione

B) Available on Request without reduction bushing
Disponibile a Richiesta senza Bussola di Riduzione

C) Motor Flange Holes Position
Posizione Fori Flangia Motore

EN Unit **H81C** is supplied without lubricant and equipped with a breather, level and drain plugs. User can add mineral oil keeping existing plugs. Should the user wish to fill it with synthetic oil, it is recommended to replace the existing plugs with a closed plug.
See table 1 for lubrication and recommended quantity.
In table 2 please see possible radial loads and axial loads on the gearbox.

I Il riduttore tipo **H81C** è fornito privo di lubrificazione con tappi di sfiato, livello e scarico olio. L'utente può immettere olio minerale mantenendo i tappi esistenti. Se immetterà olio sintetico, dovrà sostituire i tappi esistenti con altri tipo chiuso.
Tab.1 per oli e quantità consigliati.
Tab.2 carichi radiali e assiali applicabili al riduttore.

D Das Getriebe der Baugröße **H81C** wird ohne Schmiermittel geliefert. Es ist jedoch mit Einfüllschraube, Überdruckventil und Ablassschraube ausgerüstet. Das benötigte mineralische Öl kann über die Einfüllschraube eingefüllt werden. Sollte synthetisches Öl bevorzugt werden, so ist sind das eingebaute Überdruckventil durch eine geschlossenen Schraube zu ersetzen.
In Tabelle 1 ist die Schmiermenge und das empfohlene Schmiermittel angegeben
In Tabelle 2 sind die zulässigen Radial - und Axialbelastungen des Getriebes aufgeführt.

F Le réducteur de type **H81C** est fourni sans lubrification et avec un bouchon de remplissage, de niveau et d'évacuation de l'huile. L'utilisateur peut y verser de l'huile minérale en conservant les bouchons existants. S'il y versera de l'huile synthétique, il devra substituer les bouchons existants avec d'autres bouchons de type fermé.
Voir tableau 1 concernant les huiles et les quantités conseillées.
Voir tableau 2 concernant les charges radiales et axiales applicables au réducteur

E El reductor tamaño **H81C** se suministra sin lubricante, provisto de tapones de respiración, nivel y descarga de aceite. El usuario puede utilizar aceite mineral, manteniendo los tapones existentes. Si prefiere utilizar aceite sintético deberá sustituir los tapones existentes por tapones ciegos. La prerreducción se suministra con tapones ciegos, lubricado de por vida con aceite sintético.
Ver tabla 1, para cantidades y aceites recomendados.
En la tabla 2, se encuentran las cargas radiales y axiales admitidas por el reductor.

B3	B6	B7	B8	V5	V6	V8
5.70 LT	7.00 LT	7.90 LT	5.70 LT	10.20 LT	5.60 LT	Ask
SHELL Omala S2 GX 460			ENI Blasias 460			

For all details on lubrication and plugs check our website **tab. 1**
Per maggiori dettagli su lubrificazione e tappi olio vedi il nostro sito web

RADIAL AND AXIAL LOADS

Output shaft
Albero di uscita

$F_{eq} = FR \cdot \frac{227.5}{X+177.5}$

n_2	FA	FR	n_2	FA	FR	n_2	FA	FR
300	920	4600	140	1120	5600	70	1400	7000
250	1000	5000	120	1140	5700	40	1800	9000
200	1060	5300	85	1300	6500	15	2400	12000

On request reinforced bearings to increase loads.
A richiesta cuscinetti rinforzati per aumentare i carichi.

tab. 2

PH81C... Basic gearbox
Riduttore base

Gearbox weight
peso riduttore **89.0 kg**

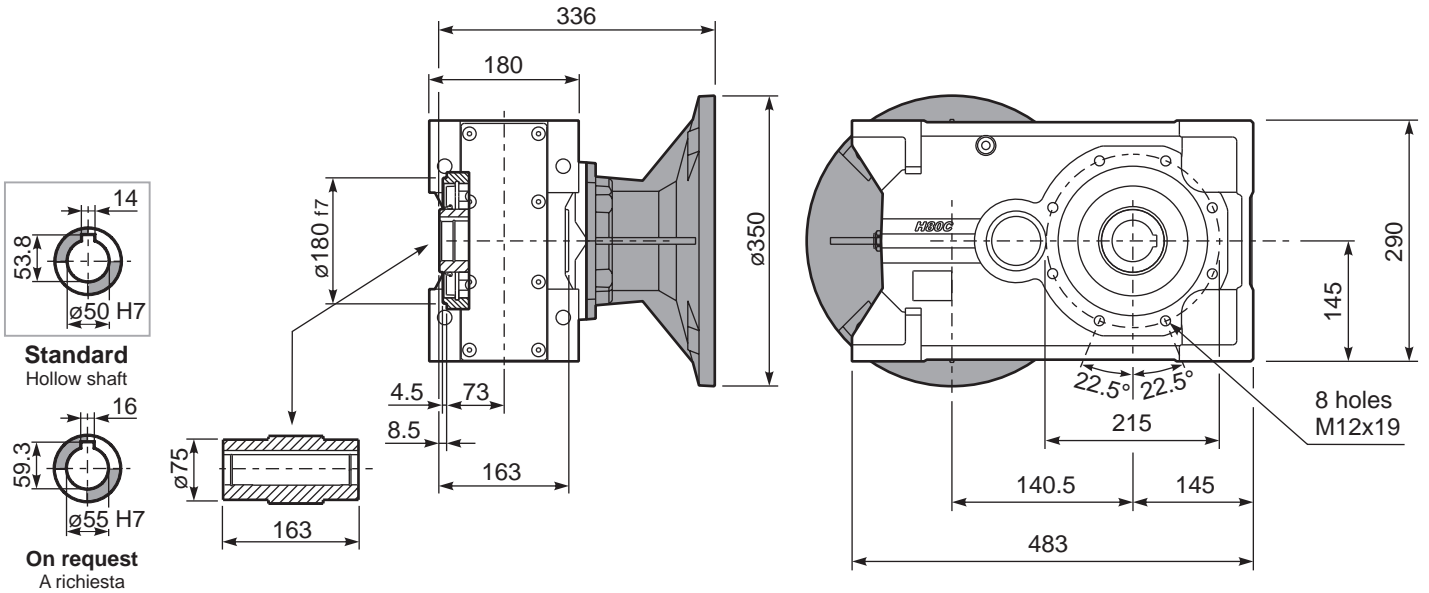

PH81C...-F Output flange
Flangia uscita

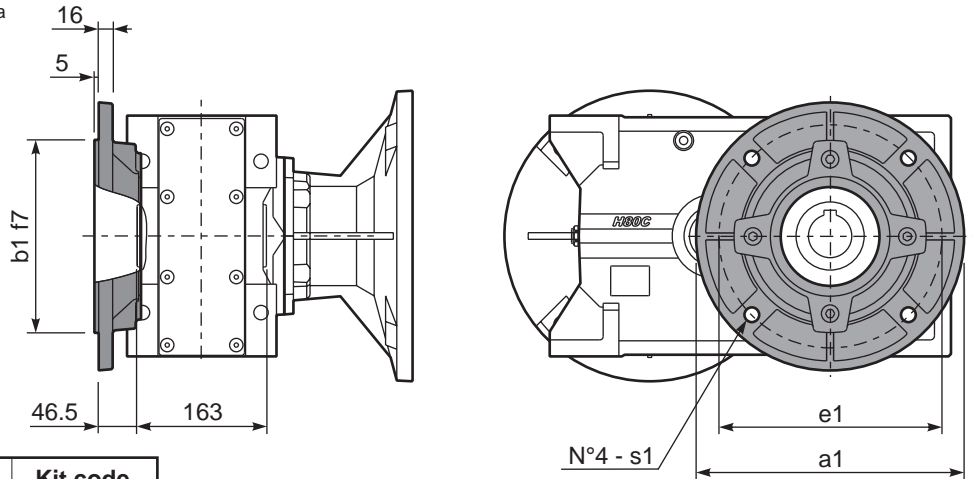

PH81C...-N Feet
Piedini

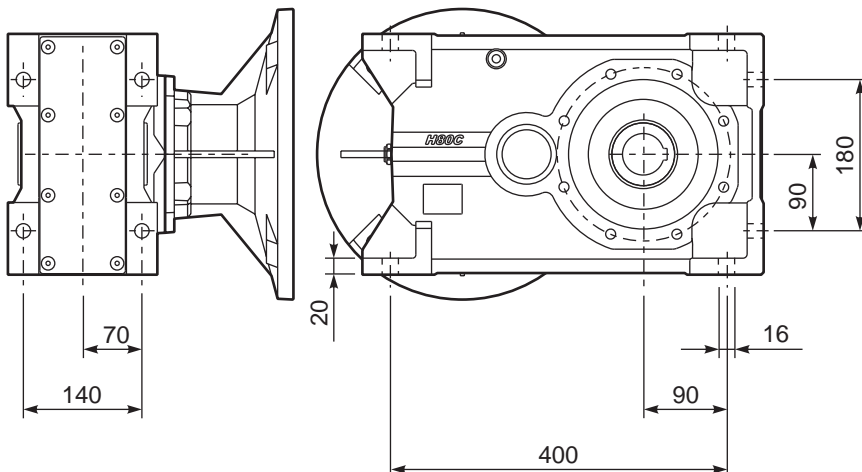

PH81C A... Single output shaft
Albero uscita semplice

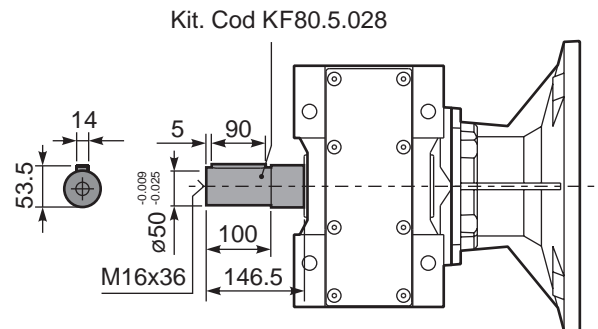



QUICK SELECTION / Selezione veloce

input speed (n_1) = 1400 min⁻¹

Output Speed n_2 [min ⁻¹]	Ratio i	Motor power P_{1M} [kW]	Output torque M_{2M} [Nm]	Service factor f.s.	Nominal power P_{1R} [kW]	Nominal torque M_{2R} [Nm]	B5 motor flanges				B14 motor flanges		Output Shaft		
							-F	-G	-H	-I	-U	-V			Ratios code
							100 112	132	160	180	100 112	132			
234	5.98	22	827	1.2	25.5	1000						3015		01	
197	7.10	22	982	1.2	25.3	1175						3013		02	
162	8.63	22	1193	1.1	23.9	1350						3011		03	
124	11.27	18.5	1310	1.1	20.3	1500						2015		04	
105	13.38	18.5	1555	1.1	19.4	1700						2013		05	
92	15.24	18.5	1771	1.1	19.0	1900						1615		06	
86	16.26	18.5	1889	1.1	19.7	2100						2011	standard ø50	07	
77	18.09	18.5	2102	1.0	17.7	2100						1613			08
71	19.82	15	1865	1.1	15.9	2060						1315	ø55 On request	09	
64	21.98	15	2069	1.0	14.6	2100						1611			10
60	23.53	15	2214	0.9	13.6	2100						1313		11	
58	24.25	11	1677	1.2	12.2	1940						1115		12	
48.6	28.80	11	1991	1.1	11.1	2100						1113		13	
40.0	34.99	9	2063	1.0	9.2	2100						1111		14	
33.6	41.64	7.5	1976	1.0	7.2	1960						813		15	
27.7	50.60	5.5	1774	1.2	6.3	2100						811		16	

The dynamic efficiency is **0.96** for all ratios

Motor Flanges Available
Flange Motore Disponibili

B) Supplied with Reduction Bushing
Fornito con Bussola di Riduzione

B) Available on Request without reduction bushing
Disponibile a Richiesta senza Bussola di Riduzione

C) Motor Flange Holes Position
Posizione Fori Flangia Motore

EN Unit **H82C** is supplied without lubricant and equipped with a breather, level and drain plugs. User can add mineral oil keeping existing plugs. Should the user wish to fill it with synthetic oil, it is recommended to replace the existing plugs with a closed plug.
See table 1 for lubrication and recommended quantity. In table 2 please see possible radial loads and axial loads on the gearbox.

I Il riduttore tipo **H82C** è fornito privo di lubrificazione con tappi di sfiato, livello e scarico olio. L'utente può immettere olio minerale mantenendo i tappi esistenti. Se immetterà olio sintetico, dovrà sostituire i tappi esistenti con altri tipo chiuso.
Tab.1 per oli e quantità consigliati.
Tab.2 carichi radiali e assiali applicabili al riduttore.

D Das Getriebe der Baugröße **H82C** wird ohne Schmiermittel geliefert. Es ist jedoch mit Einfüllschraube, Überdruckventil und Ablassschraube ausgerüstet. Das benötigte mineralische Öl kann über die Einfüllschraube eingefüllt werden. Sollte synthetisches Öl bevorzugt werden, so ist sind das eingebaute Überdruckventil durch eine geschlossenen Schraube zu ersetzen.
In Tabelle 1 ist die Schmiermenge und das empfohlene Schmiermittel angegeben
In Tabelle 2 sind die zulässigen Radial - und Axialbelastungen des Getriebes aufgeführt.

F Le réducteur de type **H82C** est fourni sans lubrification et avec un bouchon de remplissage, de niveau et d'évacuation de l'huile. L'utilisateur peut y verser de l'huile minérale en conservant les bouchons existants. S'il y versera de l'huile synthétique, il devra substituer les bouchons existants avec d'autres bouchons de type fermé.
Voir tableau 1 concernant les huiles et les quantités conseillées.
Voir tableau 2 concernant les charges radiales et axiales applicables au réducteur

E El reductor tamaño **H82C** se suministra sin lubricante, provisto de tapones de respiración, nivel y descarga de aceite. El usuario puede utilizar aceite mineral, manteniendo los tapones existentes. Si prefiere utilizar aceite sintético deberá sustituir los tapones existentes por tapones ciegos. La prerreducción se suministra con tapones ciegos, lubricado de por vida con aceite sintético.
Ver tabla 1, para cantidades y aceites recomendados.
En la tabla 2, se encuentran las cargas radiales y axiales admitidas por el reductor.

B3	B6	B7	B8	V5	V6	V8
5.60 LT	6.80 LT	7.80 LT	5.60 LT	10.00 LT	5.50 LT	Ask
SHELL Omala S2 GX 460				ENI Blasias 460		

For all details on lubrication and plugs check our website **tab. 1**
Per maggiori dettagli su lubrificazione e tappi olio vedi il nostro sito web

RADIAL AND AXIAL LOADS

Output shaft
Albero di uscita

$F_{eq} = F_R \cdot \frac{227.5}{X + 177.5}$

n_2	FA	FR	n_2	FA	FR	n_2	FA	FR
300	920	4600	140	1120	5600	70	1400	7000
250	1000	5000	120	1140	5700	40	1800	9000
200	1060	5300	85	1300	6500	15	2400	12000

On request reinforced bearings to increase loads.
A richiesta cuscinetti rinforzati per aumentare i carichi.

Input shaft
Albero in entrata

n_1	FA	FR
1400	700	3500
900	840	4200
500	900	4500

tab. 2

PH82C...

Basic gearbox
Riduttore base

Gearbox weight
peso riduttore **86.0 kg**

M. flanges	Kit code	øF	A
100/112B5	K023.4.043	250	299
132B5	KC51.4.043C	300	320.5
160/180B5	KC86.4.0.43	350	352.5
100/112B14	K085.4.047	160	299
132B14	KC51.4.041C	200	320.5

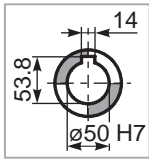

Standard
Hollow shaft

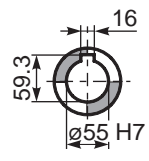

On request
A richiesta

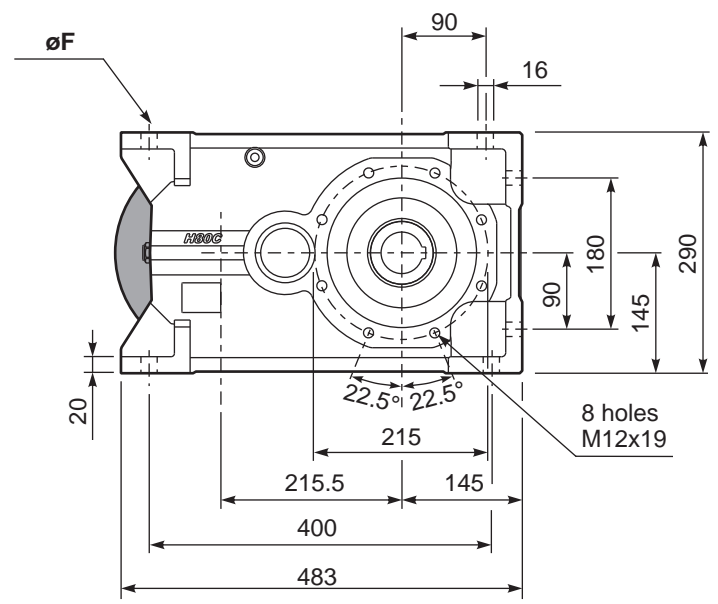
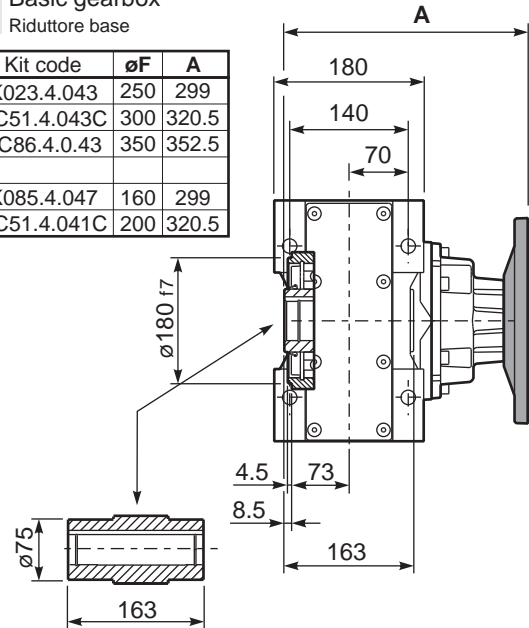

PH82C...-F

Output flange
Flangia uscita

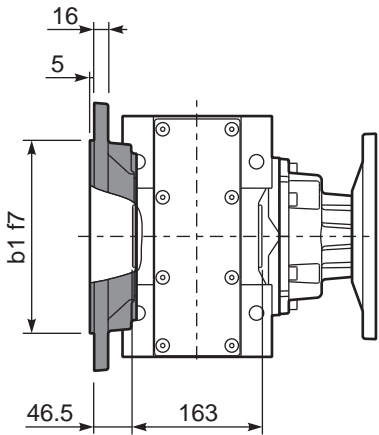

Available output flanges

Flange di uscita

a1 ø	b1	e1	s1	Kit code
300	230	265	14	KF80.9.011
350	250	300	18	KF80.9.012

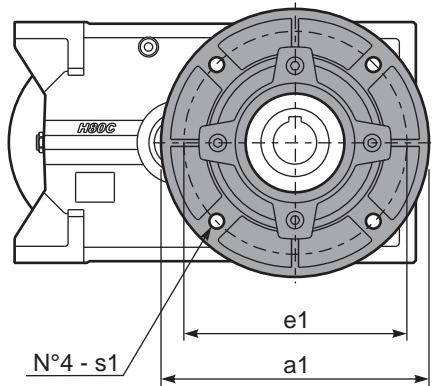

PH82C D...

Shrink disk
Calettatore

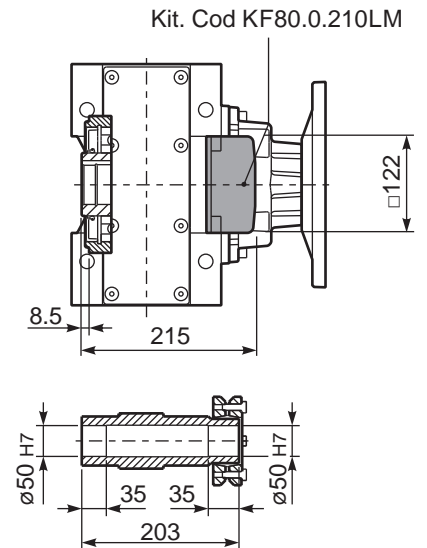

Kit. Cod KF80.0.210LM

RH82C...

Input Shaft
Albero in entrata

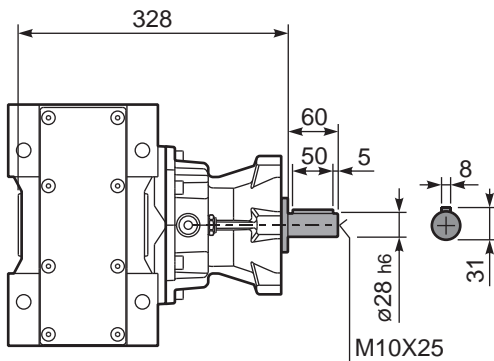

PH82C A...

Single output shaft
Albero uscita semplice

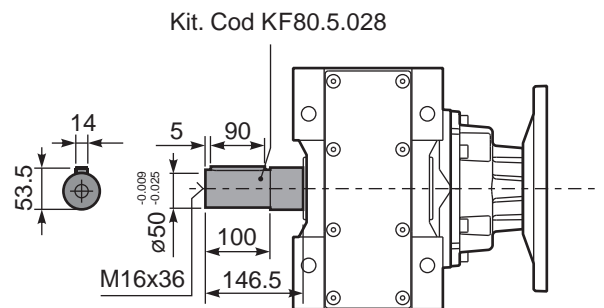

Kit. Cod KF80.5.028



QUICK SELECTION / Selezione veloce

input speed (n_1) = 1400 min⁻¹

Output Speed n_2 [min ⁻¹]	Ratio i	Motor power P_{1M} [kW]	Output torque M_{2M} [Nm]	Service factor f.s.	Nominal power P_{1R} [kW]	Nominal torque M_{2R} [Nm]	Available B5 motor flanges					Available B14 motor flanges				Output Shaft			
							-C	-D	-E	-F	-G	-R	-T	-U	-V			Ratios code	
							71	80	90	100 112	132	80	90	100 112	132				
28.8	48.55	7.5	2257	0.9	6.7	2100	B										201315	standard ø50	01
24.3	57.64	5.5	1980	1.1	5.7	2100	B										201313		02
21.3	65.64	5.5	2255	0.9	5.0	2100	B										161315		03
20.0	70.04	4	1760	1.2	4.7	2100	B										201311		04
18.0	77.93	4	1958	1.1	4.2	2100	B										161313		05
16.4	85.36	4	2145	1.0	3.8	2100	B										131315		06
14.8	94.70	4	2380	0.9	3.5	2100	B										161311		07
13.8	101.35	3	1917	1.1	3.2	2100	B										131313		08
11.4	123.15	3	2330	0.9	2.7	2100	B										131311		09
9.3	150.73	2.2	2100	1.0	2.2	2100	B										111311		10
7.8	179.39	1.5	1722	1.2	1.8	2100	B										81313		11
6.4	217.98	1.5	2093	1.0	1.5	2100	B										81311		12
5.7	247.03	1.1	1732	1.1	1.2	1950	B										61313		13
4.7	300.17	1.1	2105	1.0	1.1	2100	B										61311		14

The dynamic efficiency is **0.94** for all ratios

Motor Flanges Available
Flange Motore Disponibili

Supplied with Reduction Bushing
Fornito con Bussola di Riduzione

Available on Request without reduction bushing
Disponibile a Richiesta senza Bussola di Riduzione

Motor Flange Holes Position
Posizione Fori Flangia Motore

EN Unit **H83C** is supplied without lubricant and equipped with a breather, level and drain plugs. User can add mineral oil keeping existing plugs. Should the user wish to fill it with synthetic oil, it is recommended to replace the existing plugs with a closed plug. See table 1 for lubrication and recommended quantity. In table 2 please see possible radial loads and axial loads on the gearbox.

I Il riduttore tipo **H83C** è fornito privo di lubrificazione con tappi di sfiato, livello e scarico olio. L'utente può immettere olio minerale mantenendo i tappi esistenti. Se immetterà olio sintetico, dovrà sostituire i tappi esistenti con altri tipo chiuso. Tab.1 per oli e quantità consigliati. Tab.2 carichi radiali e assiali applicabili al riduttore.

D Das Getriebe der Baugröße **H83C** wird ohne Schmiermittel geliefert. Es ist jedoch mit Einfüllschraube, Überdruckventil und Ablassschraube ausgerüstet. Das benötigte mineralische Öl kann über die Einfüllschraube eingefüllt werden. Sollte synthetisches Öl bevorzugt werden, so ist sind das eingebaute Überdruckventil durch eine geschlossenen Schraube zu ersetzen. In Tabelle 1 ist die Schmiermenge und das empfohlene Schmiermittel angegeben. In Tabelle 2 sind die zulässigen Radial - und Axialbelastungen des Getriebes aufgeführt.

F Le réducteur de type **H83C** est fourni sans lubrification et avec un bouchon de remplissage, de niveau et d'évacuation de l'huile. L'utilisateur peut y verser de l'huile minérale en conservant les bouchons existants. S'il y versera de l'huile synthétique, il devra substituer les bouchons existants avec d'autres bouchons de type fermé. Voir tableau 1 concernant les huiles et les quantités conseillées. Voir tableau 2 concernant les charges radiales et axiales applicables au réducteur.

E El reductor tamaño **H83C** se suministra sin lubricante, provisto de tapones de respiración, nivel y descarga de aceite. El usuario puede utilizar aceite mineral, manteniendo los tapones existentes. Si prefiere utilizar aceite sintético deberá sustituir los tapones existentes por tapones ciegos. La prerreducción se suministra con tapones ciegos, lubricado de por vida con aceite sintético. Ver tabla 1, para cantidades y aceites recomendados. En la tabla 2, se encuentran las cargas radiales y axiales admitidas por el reductor.

B3	B6	B7	B8	V5	V6	V8
5.80 LT	7.10 LT	8.20 LT	5.80 LT	10.80 LT	6.00 LT	Ask
SHELL Omala S2 GX 460				ENI Blasias 460		

For all details on lubrication and plugs check our website

Per maggiori dettagli su lubrificazione e tappi olio vedi il nostro sito web

tab. 1

RADIAL AND AXIAL LOADS

Output shaft
Albero di uscita

$F_{eq} = F_R \cdot \frac{227.5}{X+177.5}$

n_2	FA	FR	n_2	FA	FR	n_2	FA	FR
300	920	4600	140	1120	5600	70	1400	7000
250	1000	5000	120	1140	5700	40	1800	9000
200	1060	5300	85	1300	6500	15	2400	12000

On request reinforced bearings to increase loads.
A richiesta cuscinetti rinforzati per aumentare i carichi.

Input shaft
Albero in entrata

n_1	FA	FR
1400	450	2250
900	500	2500
500	600	3000

tab. 2

PH83C... Basic gearbox
Riduttore base

Gearbox weight
peso riduttore **81.0 kg**

M. flanges	Kit code	øF	A
71B5	K023.4.041	160	292.5
80/90B5	K023.4.042	200	294.5
100/112B5	K023.4.043	250	303.5
132B5	KC51.4.043	300	324.5
80B14	K085.4.046	120	294.5
90B14	K085.4.045	140	294.5
100/112B14	K085.4.047	160	303.5
132B14	KC51.4.041	200	324.5

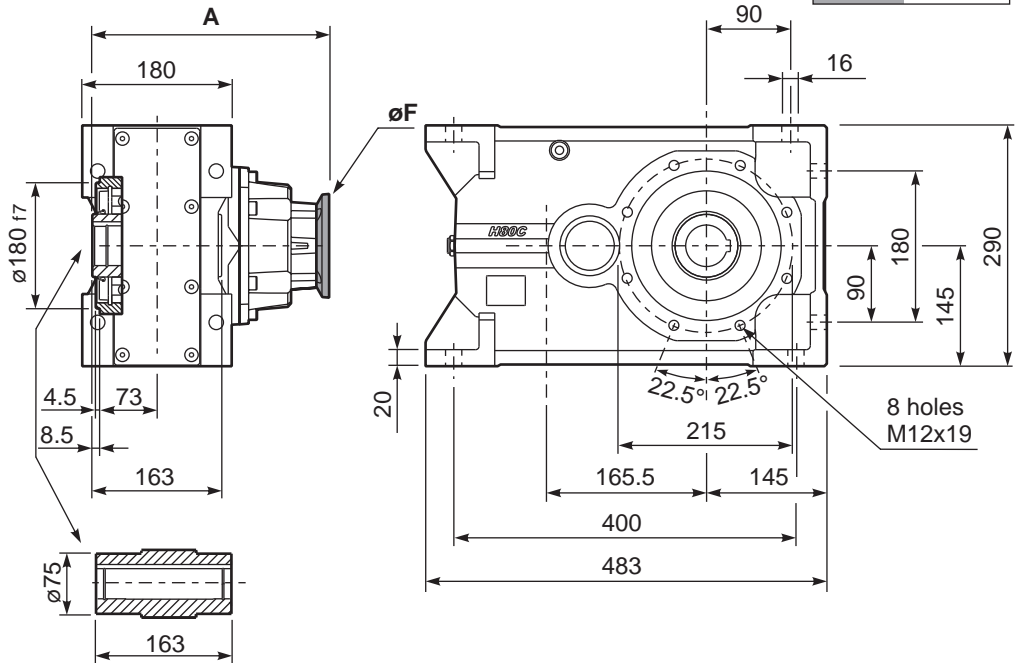

Standard
Hollow shaft

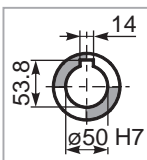

On request
A richiesta

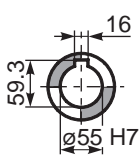

PH83C...-F Output flange
Flangia uscita

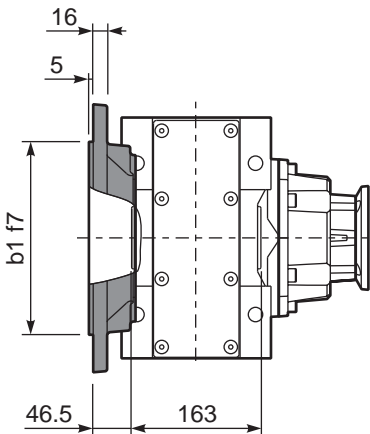

Available output flanges
Flange di uscita

a1 ø	b1	e1	s1	Kit code
300	230	265	14	KF80.9.011
350	250	300	18	KF80.9.012

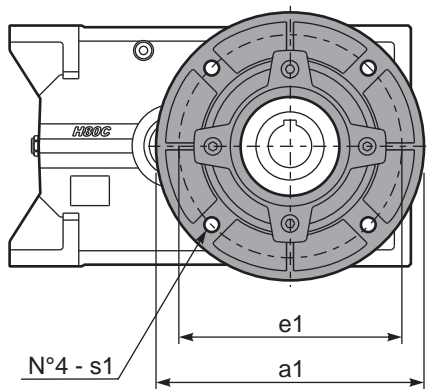

PH83C D... Shrink disk
Calettatore

Kit. Cod KF80.0.210LM

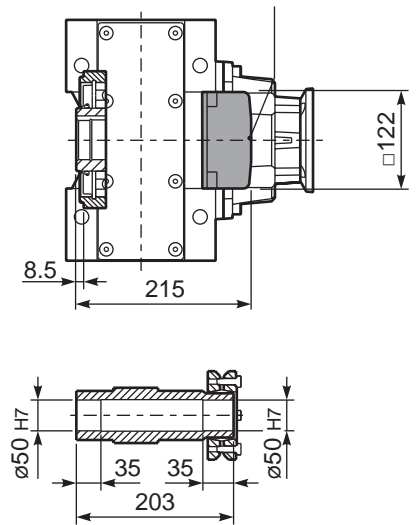

RH83C... Input Shaft
Albero in entrata

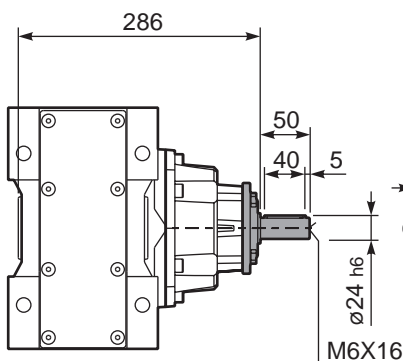

PH83C A... Single output shaft
Albero uscita semplice

Kit. Cod KF80.5.028

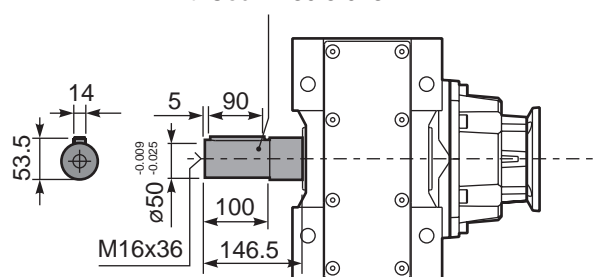

Aluminum IEC motors

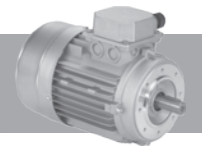

- 1) 230/400V - 50Hz three-phase asynchronous induction motor
- 2) Class F insulation
- 3) S1 duty
- 4) IP 55 protection
- 5) Not painted
- 6) Hard plastic sleeve to protect output shaft during the transportation

- 1) 230/400V - 50Hz motore trifase asincrono
- 2) Isolamento Classe F
- 3) S1 servizio continuo
- 4) Protezione IP 55
- 5) Non verniciato
- 6) Manicotto di protezione per l'albero motore

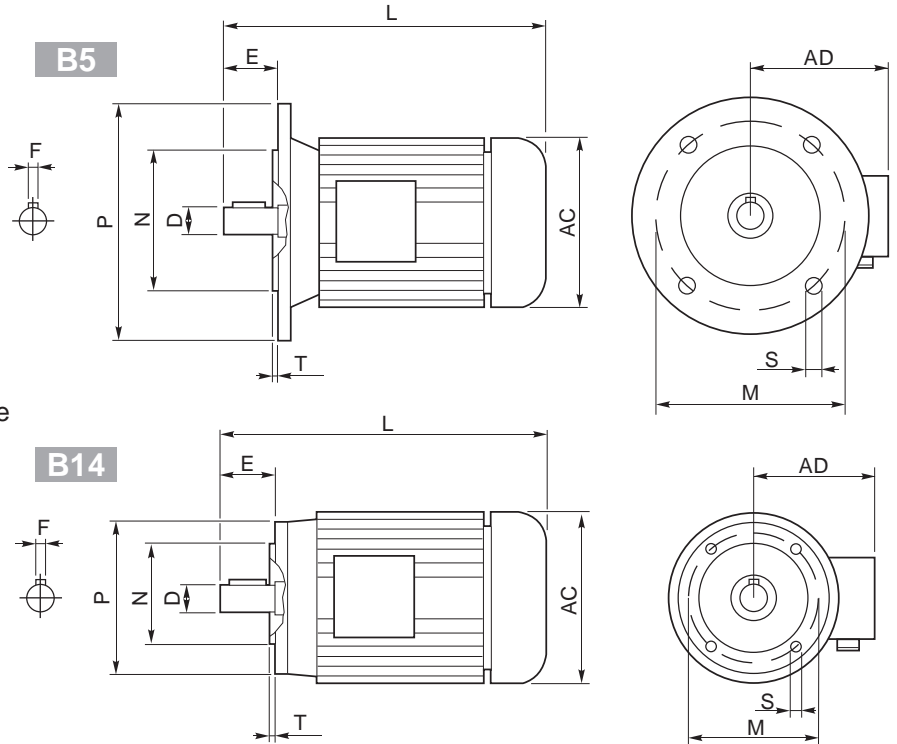

Outside dimensions and weight may be different according to manufacturers.
Le dimensioni esterne e il peso sono indicative, possono variare tra i vari costruttori.

	2 poli / poles			4 poli / poles			6 poli / poles			B5-B14						B5					B14					Kg
	kW	Nm	A _(400V)	kW	Nm	A _(400V)	kW	Nm	A _(400V)	D	F	E	L	AC	AD	N	M	P	S	T	N	M	P	S	T	
56 A	0.09	0.32	0.38	0.06	0.44	0.27	—	—	—	9	3	20	199	108	96	80	100	120	7	2.5	50	65	80	M5	2.5	2.7
56 B	0.12	0.42	0.46	0.09	0.67	0.37	—	—	—	9	3	20	199	108	96	80	100	120	7	2.5	50	65	80	M5	2.5	2.9
63 A	0.18	0.63	0.60	0.12	0.84	0.50	0.09	0.99	0.57	11	4	23	208	120	99	95	115	140	9.5	3	60	75	90	M5	2.5	3.8
63 B	0.25	0.87	0.76	0.18	1.30	0.69	0.12	1.32	0.74	11	4	23	208	120	99	95	115	140	9.5	3	60	75	90	M5	2.5	4.2
71 A	0.37	1.30	1.00	0.25	1.70	0.91	0.18	1.90	0.80	14	5	30	-	130	104	110	130	160	9.5	3.5	70	85	105	M6	2.5	5.9
71 B	0.55	1.90	1.54	0.37	2.52	1.14	0.25	2.72	1.10	14	5	30	255	141	107	110	130	160	9.5	3.5	70	85	105	M6	2.5	6.5
80 A	0.75	2.60	1.85	0.55	3.77	1.51	0.37	3.84	1.18	19	6	40	296	159	127	130	165	200	11.5	3.5	80	100	120	M6	3	8.5
80 B	1.1	3.90	2.64	0.75	5.11	2.57	0.55	5.84	1.80	19	6	40	296	159	127	130	165	200	11.5	3.5	80	100	120	M6	3	10
90 S	1.5	5.00	3.31	1.1	7.45	2.78	0.75	7.92	2.32	24	8	50	-	170	135	130	165	200	11.5	3.5	95	115	140	M8	3	12.5
90 L	2.2	7.50	4.46	1.5	10.2	3.61	1.1	11.6	3.45	24	8	50	330	170	135	130	165	200	11.5	3.5	95	115	140	M8	3	15
100 LA	3.0	10.0	6.28	2.2	14.8	5.07	1.5	15.4	3.88	28	8	60	-	190	148	180	215	250	13	4	110	130	160	M8	3.5	20
100 LB	—	—	—	3.0	20.1	6.66	—	—	—	28	8	60	-	190	148	180	215	250	13	4	110	130	160	M8	3.5	22
112 M	4.0	13.4	8.10	4.0	26.7	8.55	2.2	22.6	5.30	28	8	60	381	210	164	180	215	250	13	4	110	130	160	M8	3.5	35
132 S	5.5	18.3	11.2	5.5	36.5	11.4	3.0	30.2	7.20	38	10	80	455	244	180	230	265	300	14	4	130	165	200	M10	4	41
	7.5	24.9	15.3																							51
132 M	—	—	—	7.5	49.4	15.0	4.0	40.0	9.13	38	10	80	500	244	180	230	265	300	14	4	130	165	200	M10	4	51
	9	61.4	18.5	51																						
160 M	—	—	—	11	72	21.5	—	—	—	42	12	110	613	335	246	250	300	350	18	5	—	—	—	—	—	79.2
160 L	—	—	—	15	98	29	—	—	—	42	12	110	657	335	246	250	300	350	18	5	—	—	—	—	—	97.5
180 M	—	—	—	18.5	121	35.5	—	—	—	48	14	110	712	366	266	250	300	350	19	5	—	—	—	—	—	170
180 L	—	—	—	22	144	42	—	—	—	48	14	110	712	366	266	250	300	350	19	5	—	—	—	—	—	170
200 L	—	—	—	30	196	53	—	—	—	55	16	110	780	405	341	300	350	400	19	5	—	—	—	—	—	240
225 S	—	—	—	37	240	69	—	—	—	60	18	140	888	463	360	350	400	450	19	5	—	—	—	—	—	305
225 M	—	—	—	45	292	84	—	—	—	60	18	140	888	463	360	350	400	450	19	5	—	—	—	—	—	310

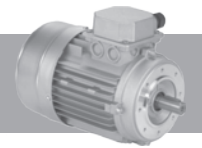

Protection

Standard IP55
Please specify on purchase orders if you need a higher IP protection class.

Grado di protezione

IP55 Standard
Specificare in sede di ordinazione per IP superiore.

Schutzart

IP55 Standard.
Höheren IP Grad bitte im Auftrag angeben.

Degré de protection

IP55 standard.
Au moment de la commande, spécifiez si vous souhaitez IP supérieur.

Grado de protección

IP55 standard.
Especificar en el pedido cuando necesiten protección IP superior.

Insulation

Standard CI.F
To be specified upon placing the order if different insulation is required.

Isolamento

CI.F Standard
Specificare in sede di ordinazione classe di isolamento diversa.

Isolierung

CI.F Standard.
Davon abweichende Isolierungsklasse im Auftrag angeben.

Isolement

CI.F Standard.
Au moment de la commande, spécifiez si vous souhaitez une classe d'isolement différente.

Aislamiento

CI.F standard.
Especificar al efectuar el pedido la clase diferente de aislamiento.

Insulation / Isolamento Isolierung /Aislamiento		E	B	F	H
Max. temp.	C°	120°	130°	155°	175°
	F*	248°	266°	311°	347°

Connections

Collegamenti

Verbindungselemente

Branchements

Conexiones

Threephase asynchronous single polarity
Asincrono trifase singola polarità
Asynchronmotor 3-ph eine Drehzahl
Moteur triphasé à une vitesse
Asincrono trifasico de una velocidad

Threephase asynchronous double polarity
Asincrono trifase doppia polarità
Asynchronmotor 3-ph doppelte Drehzahl
Moteur triphasé à deux vitesses
Asincrono trifasico de dos velocidades

Single phase asynchronous
Asincrono monofase
Einphasen-Asynchronmotor
Moteur monophasé
Asincrono monofasico

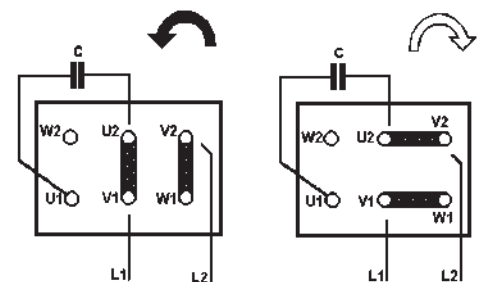
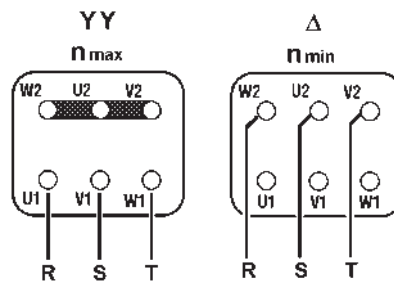
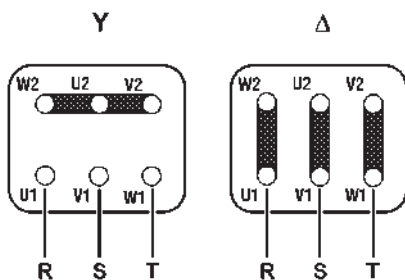

Quotations:

Unless differently agreed, the validity of all quotations is 2 months. The quotations are provided according to the RFQ (request for quotation) which shall contain the complete and detailed specification of the Product, the correctness of which is fully under responsibility of RFQ applicant.

Orders:

Only official orders issued on the Customer's letter-head are accepted. The Order Confirmation (OC) is issued within 2 working days from the order receipt unless the Products configuration issues arise. The OC shall be confirmed in writing within 2 working days from the OC date and in all its parts the product code and description, quantities and price, other specific information, if any. The OC is considered confirmed by tacit approval in case no written confirmation is provided by the Customer.

Production time:

An average production time for the standard Products is 3-4 weeks and 2-3 weeks for kits from the OC confirmation date and/or payment receipt in case of advanced payment term. For some configurations of the standard Products the production time can be different and shall be advised in the quotation and/or in any case in OC. In the period of Christmas holidays and August holidays the days of company closure are excluded from the abovementioned production term.

Delivery terms:

FCA Sovizzo, Italy (Incoterms 2016)

Packaging:

The products are packed in wooden boxes as a standard packaging. Europallets can be also used on request. The prices and details of the packaging are indicated in the apposite section of the Price List. Payment terms: the payment should be performed in terms indicated in the invoice and by wire transfer. Prices: the prices are indicated in the invoice and intended ex-works, unless differently specified, and do not include any kind of taxes, shipment or other type of costs.

Standard Products orders cancellation:

Modification or cancellation of the orders is accepted only if notified to Hydro-Mec S.p.A. in writing and not later than 3 days from the Order Confirmation and in any case before the production of the ordered Products is launched.

Special execution of customized products:

The Products that are not included in the catalogue or configurations of the products that can not be realized using catalogue, options and accessories brochure and/or online configurator (www.cleangeartech.com) are considered Customized Products.

(a) Hydro-Mec S.p.A. is entitled to examine feasibility of Special Execution of Customized Products and define the minimum quantity, production time and eventually other special sales and production conditions issuing thereafter a Special Execution Quotation that shall be confirmed by the Customer in writing.

(b) Once the Quotation is confirmed, Hydro-Mec S.p.A. shall realize a Special Execution (SE) data sheet with its unique code for each Customized product. The SE data sheet shall be confirmed in full and in writing by The Customer.

(c) The production time of SE is definitely settled by Hydro-Mec S.p.A. and notified to the Customer after the SE data sheet confirmation. As a rule, the production time for SE of Customized products is longer than standard.

(d) The orders of Special Execution of Customized products can not be cancelled unless special written agreement is made before the production of SE is launched.

WARRANTY Conditions:

(a) Warranty period is 12 months form the shipment date.

(b) Warranty period could be extended to 18 months prior written agreement of the parties and in any case excluding wearable parts.

(c) Warranty covers only manufacturing defects. Wearable parts (for example, oil seals or lubricants leakages caused by normal wear) and failures due to the wrong assembling by the Customer are not covered by warranty.

(d) This warranty is also void in any case in which the products have been misused, used in improper environment conditions, configurated beyond design limits indicated in the catalogue (especially service factor, loads and type of motors) or damaged, even accidentally or whenever installation instructions have not been strictly followed and in case of any natural disasters, in case of negligence of the Customer and the end user.

(e) The Customer is fully responsible to assure the compatibility of applications and correct mechanical couplings and electrical connections with the specifications of the Products according to Hydro-Mec S.p.A. catalogues and technical documentation

(f) The liability of Hydro-Mec S.p.A. is strictly limited to the above-stated obligations and it is therefore clearly agreed that Hydro-Mec S.p.A. take on no responsibility for any damage to persons and/or property deriving from accidents of any nature that may occur during use of the Products, whether the warranty is confirmed or otherwise, also in cases of the choice of the Product configuration being recommended by Hydro-Mec S.p.A.

WARRANTY Procedure:

(a) The Customer shall fill in the COMPLAINT FORM and forward it to Hydro-Mec S.p.A. along with other relevant information.

(b) Hydro-Mec S.p.A. examines the COMPLAINT FORM and confirms or declines the warranty.

(c) Hydro-Mec S.p.A. has the right to ask the Customer to send the malfunctioning product to Hydro-Mec S.p.A. for further examination. In case the warranty is not confirmed the Product will be shipped back to the Customer at the Customer expense. If the warranty is confirmed, Hydro-Mec S.p.A. shall compensate the shipment costs to the Customer within the limits of the best shipment quotation.

(d) In case the warranty is confirmed the Products shall be substituted at Hydro-Mec S.p.A. expense using ordinary shipment procedure. The express shipment can be used prior the agreement of the parties.

(e) In case the Product can not be substituted Hydro-Mec S.p.A. shall reimburse the value of the Product by issuing of Credit Note or in any other way agreed by the Parties.

WARNING (Please Read Carefully):

The following WARNING and CAUTION information is supplied to you for your protection and to provide you with many years of trouble free and safe operation of your product. Read ALL instructions prior to operating reducer. Injury to personnel or reducer failure may be caused by improper installation, maintenance or operation.

- (a) Written authorization is required to operate or use reducers in man lift or people moving devices.
- (b) Check to make sure that certain applications do not exceed the allowable load capacities published in the current catalog.
- (c) Buyer shall be solely responsible for determining the adequacy of the product for any and all uses to which Buyer shall apply the product. The application by Buyer shall not be subject to any implied warranty of fitness for a particular purpose.
- (d) For safety, Buyer or User should provide protective guards over all shaft extensions and any moving apparatus mounted thereon. The User is responsible for checking all applicable safety codes in his area and providing suitable guards. Failure to do so may result in bodily injury and/or damage to equipment.
- (e) Gearboxes operating in high position should have a protective shield for any possible parts falling down for casual accidents where people are moving under them.
- (f) Hot oil and reducers can cause severe burns. Use extreme care when removing lubrication plugs and vents.
- (g) Make certain that the power supply is disconnected before attempting to service or remove any components. Lock out the power supply and tag it to prevent unexpected application power.
- (h) Reducers are not to be considered fail safe or self-locking devices. If these features are required, a properly sized, independent holding device should be utilized. Reducers should not be used as a brake.
- (i) Any brakes that are used in conjunction with a reducer must be sized or positioned in such a way so as to not subject the reducer to loads beyond the catalog rating.
- (l) Lifting supports including eyebolts are to be used for vertically lifting the gearbox only and not other associated attachments or motors.
- (m) Use of an oil with an EP additive on units with backstops may prevent proper operation of the back-stop. Injury to personnel, damage to the reducer or other equipment may result.
- (n) Overhung loads subject shaft bearings and shafts to stress which may cause premature bearing failure and or shaft breakage from bending fatigue, if not sized properly.

Our company will not be responsible for any direct or indirect damages, caused by a wrong use of the products or for not observing the catalogue/web indication.

1) Definizioni

1.1 Ai fini delle presenti condizioni generali di vendita (di seguito denominate “Condizioni di Vendita”), i seguenti termini avranno il significato di seguito ad essi attribuito:

- “HM”: Hydro-Mec S.p.A.;
- “Cliente”: qualunque società, ente o entità giuridica che acquisti i Prodotti di HM da quest’ultima;
- “Prodotti”: i beni prodotti, assemblati e/o venduti da HM;
- “Ordine/i”: ciascuna proposta di acquisto dei Prodotti inoltrata dal Cliente ad HM esclusivamente tramite e-mail, fax o web;
- “Vendita/e”: ciascun contratto di vendita concluso tra HM e il Cliente a seguito del ricevimento da parte del Cliente dell’accettazione scritta dell’Ordine da parte di HM;

2) Scopi

2.1 Le presenti Condizioni di Vendita si applicano a tutte le Vendite di Prodotti. Nel caso di contrasto tra le condizioni e i termini di cui alle presenti Condizioni di Vendita e le condizioni e i termini pattuiti nella singola Vendita, quest’ultimi prevarranno. HM non sarà vincolata da condizioni generali di acquisto del Cliente (di seguito, “CGA”), neanche nell’ipotesi in cui si faccia loro riferimento o siano contenute negli ordini o in qualsiasi altra documentazione di provenienza del Cliente, senza il preventivo consenso scritto di HM. Le CGA non saranno vincolanti per HM neppure per effetto di tacito consenso.

2.2 HM si riserva il diritto di aggiungere, modificare o eliminare qualsiasi previsione delle presenti Condizioni di Vendita, restando inteso che tali aggiunte, modifiche o cancellazioni si applicheranno a tutte le Vendite concluse a partire dal trentesimo giorno successivo alla notifica al Cliente delle nuove Condizioni di Vendita.

3) Ordini e Vendite

3.1 Il Cliente dovrà inoltrare a HM Ordini specifici contenenti la descrizione dei Prodotti, la quantità richiesta, il prezzo ed i termini richiesti per la consegna.

3.2 La Vendita dovrà ritenersi conclusa: (i) nel momento in cui il Cliente riceva da parte di HM una conferma scritta (tale conferma potrà essere inviata via e-mail, fax o mezzi telematici) conforme ai termini e alle condizioni dell’Ordine (ii) o, nel caso in cui il Cliente riceva da parte di HM una conferma scritta contenente termini difformi da quelli contenuti nell’Ordine, decorsi tre giorni lavorativi dalla data di ricezione della conferma contenente termini difformi senza che nel suddetto periodo pervenga a HM contestazione scritta da parte del Cliente; (iii) o, in assenza di conferma scritta da parte di HM, nel momento in cui i Prodotti saranno consegnati al Cliente.

3.3 Gli Ordini regolarmente accettati da HM non potranno essere annullati dal Cliente senza il consenso scritto di HM.

4) Prezzo dei Prodotti

4.1 I prezzi dei Prodotti saranno quelli indicati nel listino prezzi di HM in vigore al momento dell'inoltro dell'Ordine da parte del Cliente o, qualora il Prodotto non sia inserito nel listino prezzi o il listino prezzi non sia disponibile, quelli indicati nell'Ordine e confermati per iscritto da HM al momento dell'accettazione dell'Ordine. Eccetto quanto diversamente concordato per iscritto tra le parti, i predetti prezzi saranno calcolati franco fabbrica, al netto dell'IVA e degli sconti. Tali prezzi non comprendono i costi di imballaggio, spedizione e trasporto dai locali di HM a quelli del Cliente. Tali costi dovranno essere sostenuti separatamente dal Cliente.

4.2 HM manterrà la proprietà dei Prodotti fino alla completa corresponsione del prezzo degli stessi. Il Cliente dovrà compiere tutti gli adempimenti richiesti dalle leggi locali al fine di rendere valida ed eseguibile nei confronti di tutti i terzi la presente clausola di riserva della proprietà anche operando l'iscrizione in ogni apposito registro, ove localmente richiesto.

5) Termini di consegna

5.1 Eccetto quanto eventualmente diversamente concordato per iscritto tra le parti, HM consegnerà i prodotti franco fabbrica presso i propri stabilimenti, così come questo termine è definito negli INCOTERMS 2010 pubblicati dalla Camera di Commercio internazionale nella loro versione più aggiornata, in vigore al momento della consegna. Se richiesto, HM si occuperà del trasporto dei Prodotti a rischio, costi e spese del Cliente.

5.2 La consegna dovrà avvenire entro il termine indicato nell'Ordine come accettato nella conferma d'ordine. I termini di consegna sono indicativi e non sono termini essenziali ai sensi dell'art. 1457 del Codice Civile e, in ogni caso, non includono i tempi di trasporto.

5.3 Salvo quanto previsto dal precedente art. 5.2, HM non sarà considerata responsabile dei ritardi o della mancata consegna ascrivibili a circostanze che siano fuori dal suo controllo, quali a titolo meramente esemplificativo e senza pretesa di esaustività:

- a) dati tecnici inadeguati o imprecisioni o ritardi del Cliente nella trasmissione a HM di informazioni o dati necessari alla spedizione dei Prodotti;
- b) difficoltà nell'ottenere rifornimenti delle materie prime;
- c) problemi legati alla produzione o alla pianificazione degli ordini;
- d) scioperi parziali o totali, mancanza di energia elettrica, calamità naturali, misure imposte dalle autorità pubbliche, difficoltà nel trasporto, cause di forza maggiore, disordini, attacchi terroristici e tutte le altre cause di forza maggiore;
- e) ritardi da parte dello spedizioniere.

5.4 Il verificarsi di alcuni degli eventi sopra elencati non darà diritto al Cliente di richiedere il risarcimento degli eventuali danni o indennizzi di alcun genere.

6) Trasporto

6.1 Eccetto quanto eventualmente diversamente concordato per iscritto tra le parti, il trasporto avverrà sempre a spese e rischio del Cliente. Nel caso in cui a HM, ai sensi dell'art. 5.1, venga richiesto di occuparsi del trasporto dei Prodotti, HM sceglierà il mezzo di trasporto che riterrà più appropriato in mancanza di specifiche istruzioni del Cliente.

7) Pagamenti

7.1 Salvo diverso accordo scritto tra le parti, HM emetterà le fatture al momento della consegna dei Prodotti.

7.2 Il mancato pagamento nel tempo concordato darà diritto a HM di chiedere al Cliente il pagamento degli interessi scaduti al tasso stabilito dal Decreto Legislativo n. 231/02.

7.3 Il mancato pagamento o il ritardo nei pagamenti superiore a 30 giorni daranno a HM il diritto di sospendere la consegna dei Prodotti e risolvere ogni singola Vendita sottoscritta. La sospensione della consegna dei Prodotti o la risoluzione delle Vendite non darà il diritto al Cliente di pretendere alcun risarcimento dei danni.

7.4 Ogni reclamo relativo ai Prodotti e/o alla consegna dei medesimi non potrà in alcun caso giustificare la sospensione o il ritardo nel pagamento.

8) Non-conformità

8.1 Qualsiasi difformità dei Prodotti consegnati al Cliente rispetto al tipo ed alla quantità indicata nell'Ordine dovrà essere denunciata per iscritto a HM entro cinque giorni dalla data di consegna. Qualora la denuncia non venga comunicata entro il predetto termine, i Prodotti consegnati verranno considerati come conformi a quelli ordinati dal Cliente.

9) Garanzia

9.1 Salvo diverso accordo scritto tra le parti, HM garantisce che i Prodotti sono esenti da vizi/difetti (con esclusione di quelle parti dei Prodotti che non sono prodotte da HM) per un periodo di 12 mesi decorrente dalla data di consegna dei medesimi al Cliente.

9.2 La garanzia non opererà con riferimento a quei Prodotti i cui difetti sono dovuti a

- danni causati durante il trasporto;
- un uso negligente o improprio degli stessi;
- inosservanza delle istruzioni di HM relative al funzionamento, manutenzione ed alla conservazione dei Prodotti;
- riparazioni o modifiche apportate dal Cliente o da soggetti terzi senza la previa autorizzazione scritta di HM.

9.3 A condizione che il reclamo del Cliente sia coperto dalla garanzia e notificato nei termini di cui al presente articolo, HM si impegnerà, a sua discrezione, a sostituire o riparare ciascun Prodotto o le parti di questo che presentino vizi o difetti.

9.4 Il Cliente dovrà denunciare per iscritto a HM, la presenza di vizi o difetti entro 8 giorni dalla consegna dei Prodotti se si tratta di vizi o difetti palesi, oppure, entro 8 giorni dalla scoperta in caso di vizi o difetti occulti o non rilevabili da una persona di media diligenza.

9.5 I Prodotti oggetto di denuncia dovranno essere immediatamente inviati presso la fabbrica di HM, o in qualsiasi altro luogo che quest'ultima indicherà di volta in volta, a costi e spese a carico del Cliente salvo diverso accordo tra le parti, al fine di consentire a HM l'espletamento dei necessari controlli. La garanzia non copre danni e/o difetti dei Prodotti derivanti da anomalie causate da, o connesse a, parti assemblate/aggiunte direttamente dal Cliente o dal consumatore finale. Qualora, nell'ambito della presente garanzia, un Prodotto o un componente difettoso venisse sostituito, la proprietà del Prodotto o del componente sostituito sarà ritrasferita dal Cliente a HM.

9.6 In ogni caso il Cliente non potrà far valere i diritti di garanzia verso HM se il prezzo dei Prodotti non sia stato corrisposto alle condizioni e nei termini pattuiti, anche nel caso in cui la mancata corresponsione del prezzo alle condizioni e nei termini pattuiti si riferisca a Prodotti diversi da quelli per i quali il Cliente intende far valere la garanzia.

9.7 HM non riconosce alcuna garanzia circa la conformità dei Prodotti alle norme e ai regolamenti di Paesi che non rientrano o non appartengono all'Unione Europea. Nessun'altra garanzia, espressa o implicita, quale, a titolo esemplificativo, la garanzia di buon funzionamento o di idoneità per uno scopo specifico, è concessa con riferimento ai Prodotti.

9.8 Senza pregiudizio a quanto indicato nel precedente art. 9.3 e salvo il caso di dolo o colpa grave, HM non sarà responsabile per qualsivoglia danno derivante e/connesso ai vizi dei Prodotti. In ogni caso, HM non sarà ritenuto responsabile per danni indiretti o consequenziali di qualsiasi natura quali, a titolo esemplificativo, le perdite derivanti dall'inattività del Cliente o il mancato guadagno.

10) Diritti di Proprietà Intellettuale

10.1 I Diritti di Proprietà Intellettuale sono di totale ed esclusiva proprietà di HM e la loro comunicazione o utilizzo nell'ambito delle presenti Condizioni di Vendita non crea, in relazione ad essi, alcun diritto o pretesa in capo al Cliente. Il Cliente si obbliga a non compiere alcun atto incompatibile con la titolarità dei Diritti di Proprietà Intellettuale.

11) Clausola risolutiva espressa

11.1 HM avrà facoltà di risolvere, ai sensi e per gli effetti dell'art. 1456 del Codice Civile Italiano, in qualsiasi momento mediante comunicazione scritta da inviare al Cliente, la singola Vendita nel caso di inadempimento delle obbligazioni previste dagli articoli: 4 (Prezzo dei Prodotti); 7 (Pagamenti); 10 (Diritti di Proprietà Intellettuale).

12) Mutamento nelle condizioni patrimoniali del Cliente

12.1 HM avrà diritto a sospendere l'adempimento delle obbligazioni derivanti dalla Vendita dei prodotti, in base all'art. 1461 del Codice Civile Italiano, nel caso in cui le condizioni patrimoniali del Cliente divenissero tali da porre in serio pericolo il conseguimento della controprestazione salvo che sia prestata idonea garanzia.

13) Domicilio legale, legge applicabile e giurisdizione

13.1 HM è legalmente domiciliata presso la sua sede principale.

13.2 Le Condizioni di Vendita e ogni singola Vendita saranno regolate e interpretate in conformità alla Legge Italiana.

13.3 Tutte le controversie derivanti da o connesse alle presenti Condizioni di Vendita e/o ad ogni Vendita saranno soggette alla esclusiva giurisdizione del Tribunale di Vicenza.

13.4 Salvo quanto pattuito nel precedente art. 13.3, HM si riserva il diritto, quando promotore di una azione legale in qualità di attore, di promuovere tale azione nel luogo di residenza del Cliente.

14) ATTENZIONE (Leggere attentamente):

Le seguenti raccomandazioni sono fondamentali per la vostra protezione e per garantirvi molti anni di sicuro funzionamento del vostro prodotto senza alcun problema.

Leggere attentamente tutte le istruzioni prima di azionare il riduttore. L'inappropriata installazione, manutenzione o funzionamento del riduttore può causare incidenti al personale addetto e danni al riduttore stesso.

14.1 E' richiesta autorizzazione scritta per azionare riduttori in ascensori o dispositivi per il movimento delle persone.

14.2 Controllare che alcune applicazioni non eccedano la massima capacità di carico ammessa pubblicata in questo catalogo.

14.3 L'acquirente è l'unico responsabile per la determinazione dell'adeguatezza del prodotto per qualcuna o tutte le utilizzazioni che l'acquirente stesso farà del riduttore. L'applicazione dell'acquirente non potrà essere soggetta ad alcuna implicita garanzia di montaggio per uno scopo particolare.

14.4 Per ragioni di sicurezza l'acquirente dovrà provvedere a porre protezioni adeguate su tutta la lunghezza dell'albero a tutti gli organi in movimento. L'utilizzatore è responsabile del controllo di tutti i codici di sicurezza e la predisposizione di protezioni adeguate. In assenza di tali precauzioni si possono verificare incidenti alle persone e danni agli apparati.

14.5 Su riduttori installati in posizioni elevate utilizzare protezioni adeguate per qualsiasi distacco accidentale di parti nel caso di passaggio di persone al di sotto.

14.6 Olio e riduttori bollenti possono causare gravi ustioni. Usare estrema cautela nella rimozione dei tappi e delle ventole.

14.7 Assicurarsi che la corrente di alimentazione sia scollegata prima di riparare o rimuovere alcun componente. Chiudere l'alimentazione e contrassegnare tale operazione per evitare accensioni accidentali.

14.8 I riduttori non devono essere considerati esenti da guasti o a bloccaggio automatico. Se sono indispensabili queste caratteristiche, deve essere utilizzato un dispositivo indipendente della dimensione adatta. I riduttori non devono essere utilizzati come freni.

14.9 Qualsiasi freno sia utilizzato insieme al riduttore deve essere della giusta grandezza e posizionato in modo da non causare carichi eccessivi non previsti dai dati forniti nel catalogo.

14.10 I dispositivi di sollevamento come le golfare devono essere usati solo per sollevare verticalmente il riduttore e non altri dispositivi associati o motori.

14.11 L'utilizzo di un olio con un additivo EP su gruppi provvisti di dispositivo di arresto possono inficiare l'uso corretto del freno e provocare danni alle persone, alle cose ed al riduttore stesso nonché ad altri apparecchi.

14.12 I Carichi sospesi assoggettano i cuscinetti della vite e la vite stessa a sollecitazioni che possono causare, se non adeguatamente dimensionati, l'usura prematura dei cuscinetti e/o la rottura della vite a causa della resistenza alla flessione.

La nostra ditta non si ritiene responsabile per eventuali danni diretti o indiretti derivanti da un uso improprio dei prodotti e dalla mancata osservanza delle indicazioni riportate a catalogo o web.

HYDRO · MEC

HIGH EFFICIENCY GEARBOXES

Via della Tecnica, 19 - 36050 Sovizzo (VI)
Tel. +39 0444551911 - Fax. +39 0444 536139
hydromec@hydromec.com



GT-GBM-RFX-HM024-ML

