

ANGLETECH GEARS

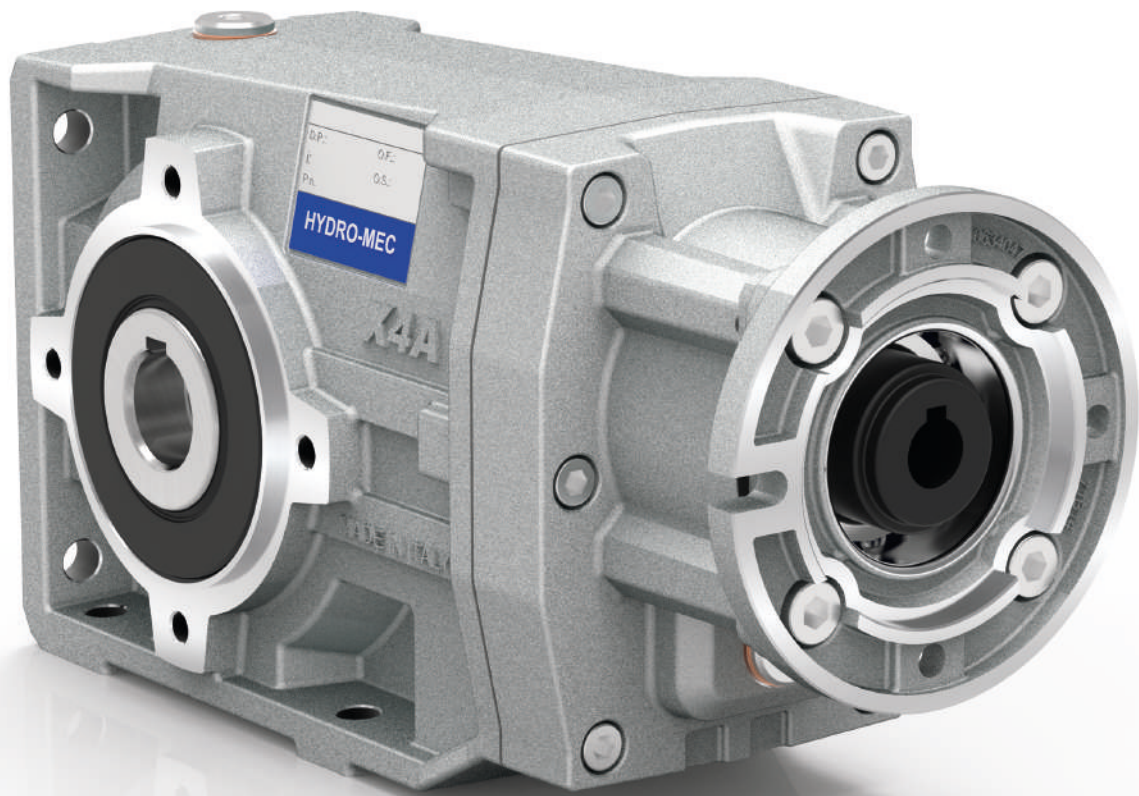

Edition 2024

HYDRO · MEC
HIGH EFFICIENCY GEARBOXES

Aluminum and cast iron helical bevel gearboxes

A modular and compact product
Very energy efficient drive

Removable inspection cover

Allows periodic inspection of gearing during routine maintenance

Gears

Hardened and ground gears

Alloy housing

Is vacuum impregnated (MIL-STD 276) for protection and sealing. No secondary finish required but readily accepts paint.

Oil seals

Two oil seals on request

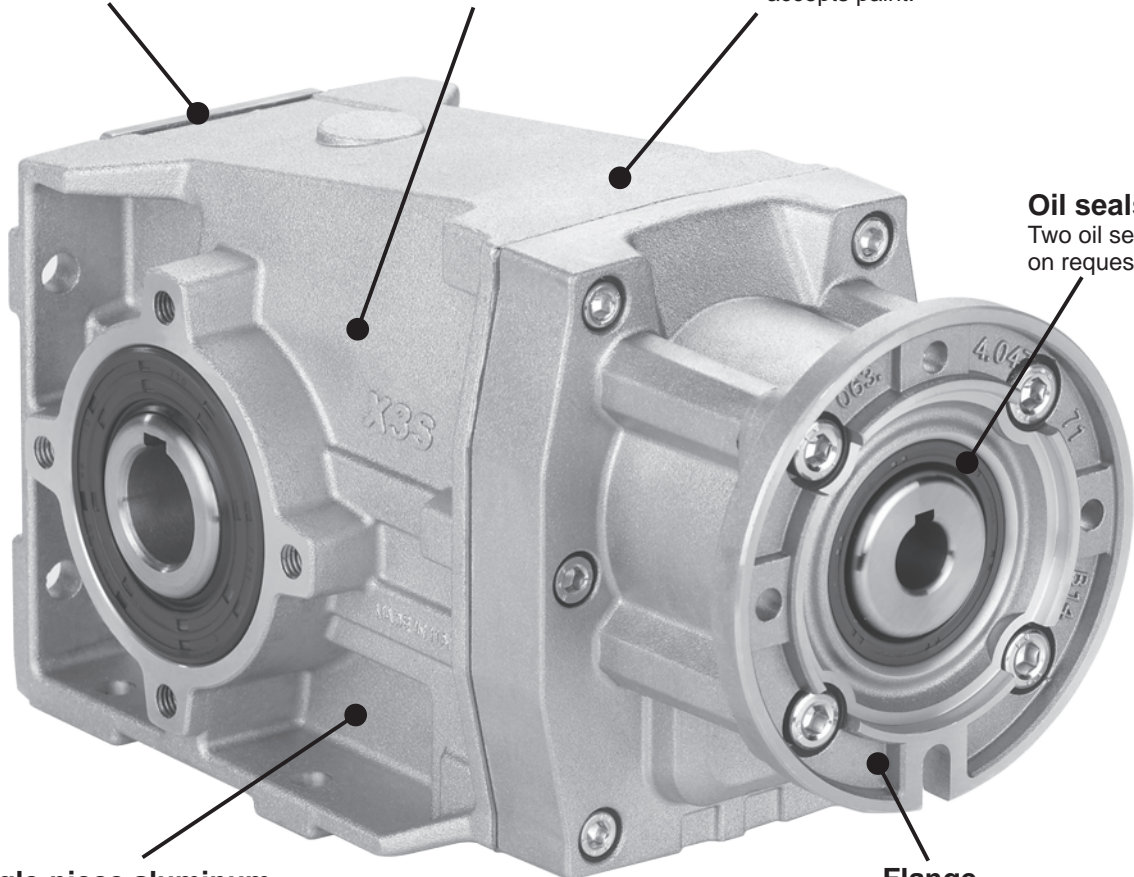

Single-piece aluminum

Combines light weight with high tensile strength. Precision machined for alignment of bearings and gearing

Flange

Fully modular to IEC and Compact integrated motor. NEMA C flange

Cast Iron housing

With high tensile strength. Precision machined for alignment of bearings and gearing

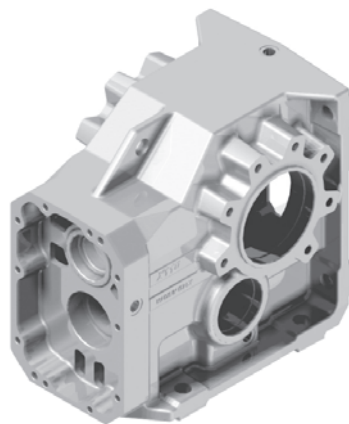
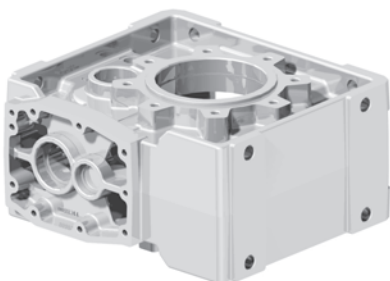

Painting

Cast iron gearboxes are painted RAL 7046



World wide sales network.

Specific type datasheet on page...

On page / A pagina / Auf Seite / À la page / En la página

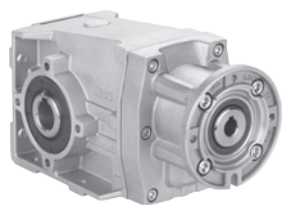

Types / Tipi
Typen / Types
Tipos

9-5	9-7	9-9	9-11	9-13	9-15	9-17	9-19	9-21
X22S 50Nm	X32S 90Nm	X33S 100Nm	X42A 150Nm	X43A 160Nm	X52A 250Nm	X53A 250Nm	X62A 410Nm	X63A 410Nm

On page / A pagina / Auf Seite / À la page / En la página

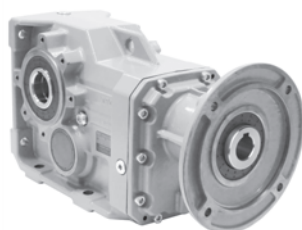

Types / Tipi
Typen / Types
Tipos

9-23	9-25	9-27	9-29	9-31	9-33	9-35	9-37	9-39	9-41
X73C 675Nm	X74C 675Nm	X83C 1000Nm	X84C 1000Nm	X93C 1600Nm	X94C 1650Nm	X103 3000Nm	X104 3000Nm	X113 4500Nm	X114 4600Nm

On page / A pagina / Auf Seite / À la page / En la página

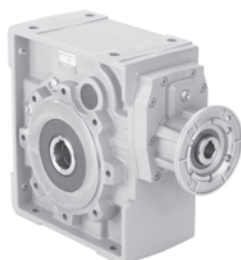

Types / Tipi
Typen / Types
Tipos

9-43	9-45	9-47	9-49
113C 675Nm	114C 675Nm	133C 1000Nm	134C 1000Nm

On page / A pagina / Auf Seite / À la page / En la página

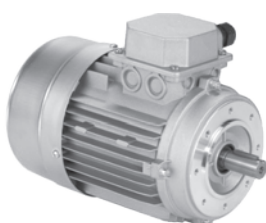





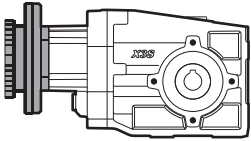
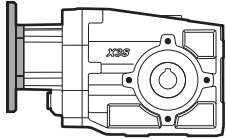
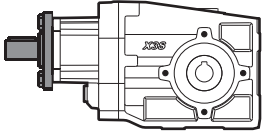
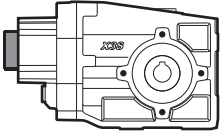
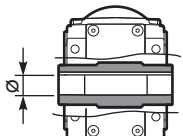
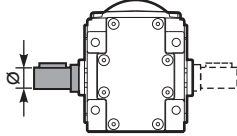
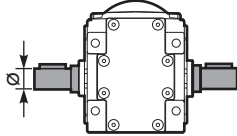
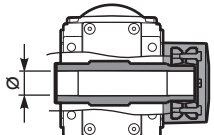
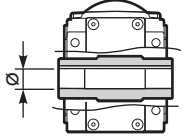
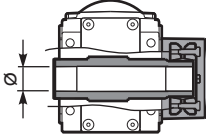

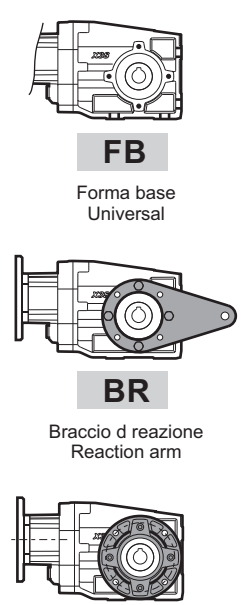
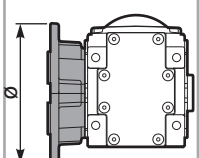

Types / Tipi
Typen / Types
Tipos

M-1									
56A 56B	63A 63B	71A 71B	80A 80B	90S 90L	100LA 100LB	112M	132S 132M	160M 160L	180M 180L

Type - Tipo - Typ Type - Tipo	Size - Grandezza - Grösse Taille - Tamaño	Hub - Mozzo corona Hohlwelle Arbre creux Nucleo corona	Rapporto - Ratio Untersetzung Reduction Relacion	Output shaft - Albero uscita Ausgangsflansch Arbre de sortie Brida en salida																																																																				
M	X22S	C	4.83	-A																																																																				
<p>Helical-bevel gear Riduttori ortogonali</p>  <p>With IEC motor M</p>  <p>With motor flange P</p>  <p>With male input shaft R</p>  <p>Modular base B</p> <p>Not available for: X93C, X103, X104, X113, X114.</p>	<p>2 Stages Riduzioni Stufen Trains Etapas</p> <p>3 Stages Riduzioni Stufen Trains Etapas</p> <p>Aluminum Alluminio Aluminium Aluminium Aluminio</p> <p>X22S X32S X42A X52A X62A</p> <p>3 Stages Riduzioni Stufen Trains Etapas</p> <p>4 Stages Riduzioni Stufen Trains Etapas</p> <p>Cast Iron Ghisa Grauguss Fonte Fundicion</p> <p>113C 133C X73C X83C X93C X103 X113</p> <p>114C 134C X74C X84C X94C X104 X114</p>	<p>Hollow output shaft C</p>  <p>Single output shaft A</p>  <p>Double output shaft only for 113/4C, 133/4C, X73/4C, X83/4C, X93/4C, X103/4 and X113/4 B</p>  <p>Shrink Disk (only on the DX side) D</p>  <p>Only on request for Q.ty A richiesta per quantità</p> <p>Stainless steel hub I</p>  <p>Stainless steel hub Mozzo in acciaio Inox Edelstahlhohlwelle Moyeu en acier Inox Nucleo corona de acero Inox</p> <p>Only on request for Q.ty A richiesta per quantità</p>	<p>See technical data table</p> <p>Vedi tabelle dati tecnici.</p> <p>Technisches Datenblatt beachten</p> <p>Voir Tableau données techniques</p> <p>Ver tabla datos técnicos</p>	<p>STANDARD Hollow output shaft</p> <table border="1"> <tr> <td>X22S</td> <td>-F ⇒ ø40</td> </tr> <tr> <td>-A ⇒ ø18</td> <td>-H ⇒ ø45</td> </tr> <tr> <td>-B ⇒ ø20</td> <td>113C 114C</td> </tr> <tr> <td>X32S X33S</td> <td>-F ⇒ ø40</td> </tr> <tr> <td>-B ⇒ ø20</td> <td>-G ⇒ ø42</td> </tr> <tr> <td>-C ⇒ ø25</td> <td>133C 134C</td> </tr> <tr> <td>X42A X43A</td> <td>-F ⇒ ø40</td> </tr> <tr> <td>-C ⇒ ø25</td> <td>-H ⇒ ø45</td> </tr> <tr> <td>-D ⇒ ø30</td> <td>X93C X94C</td> </tr> <tr> <td>X52A X53A</td> <td>-H ⇒ ø45</td> </tr> <tr> <td>-D ⇒ ø30</td> <td>-J ⇒ ø50</td> </tr> <tr> <td>-E ⇒ ø35</td> <td>X103 X104</td> </tr> <tr> <td>X62A X63A</td> <td>-K ⇒ ø60</td> </tr> <tr> <td>-E ⇒ ø35</td> <td>X113 X114</td> </tr> <tr> <td>-F ⇒ ø40</td> <td>-T ⇒ ø70</td> </tr> </table> <p>Single and double output shaft</p> <table border="1"> <tr> <td>-I</td> <td>X22S ⇒ ø20</td> </tr> <tr> <td>-L</td> <td>X32/3S ⇒ ø25</td> </tr> <tr> <td>-M</td> <td>X42/3A ⇒ ø30</td> </tr> <tr> <td>-N</td> <td>X52/3A ⇒ ø35</td> </tr> <tr> <td>-V</td> <td>X62/3A ⇒ ø35</td> </tr> <tr> <td>-P</td> <td>X73/4A* ⇒ ø40*</td> </tr> <tr> <td>-1</td> <td>133/4C ⇒ ø45*</td> </tr> <tr> <td>-3</td> <td>X93/4C ⇒ ø50*</td> </tr> <tr> <td>-5</td> <td>X103/4 ⇒ ø60*</td> </tr> <tr> <td>-5</td> <td>X113/4 ⇒ ø70*</td> </tr> </table> <p>* Also available double output shaft</p>  <p>Shrink Disk</p> <table border="1"> <tr> <td>-U</td> <td>X22S ⇒ ø20</td> </tr> <tr> <td>-Q</td> <td>X32/3S ⇒ ø30</td> </tr> <tr> <td>-R</td> <td>X42/3A ⇒ ø35</td> </tr> <tr> <td>-S</td> <td>X52/3A ⇒ ø35</td> </tr> <tr> <td>-6</td> <td>X62/3A ⇒ ø40</td> </tr> <tr> <td>-7</td> <td>X73/4A ⇒ ø45</td> </tr> <tr> <td>-8</td> <td>X83/4A ⇒ ø50</td> </tr> <tr> <td>-9</td> <td>X93/4C ⇒ ø65</td> </tr> <tr> <td>-9</td> <td>X103/4 ⇒ ø75</td> </tr> </table>	X22S	-F ⇒ ø40	-A ⇒ ø18	-H ⇒ ø45	-B ⇒ ø20	113C 114C	X32S X33S	-F ⇒ ø40	-B ⇒ ø20	-G ⇒ ø42	-C ⇒ ø25	133C 134C	X42A X43A	-F ⇒ ø40	-C ⇒ ø25	-H ⇒ ø45	-D ⇒ ø30	X93C X94C	X52A X53A	-H ⇒ ø45	-D ⇒ ø30	-J ⇒ ø50	-E ⇒ ø35	X103 X104	X62A X63A	-K ⇒ ø60	-E ⇒ ø35	X113 X114	-F ⇒ ø40	-T ⇒ ø70	-I	X22S ⇒ ø20	-L	X32/3S ⇒ ø25	-M	X42/3A ⇒ ø30	-N	X52/3A ⇒ ø35	-V	X62/3A ⇒ ø35	-P	X73/4A* ⇒ ø40*	-1	133/4C ⇒ ø45*	-3	X93/4C ⇒ ø50*	-5	X103/4 ⇒ ø60*	-5	X113/4 ⇒ ø70*	-U	X22S ⇒ ø20	-Q	X32/3S ⇒ ø30	-R	X42/3A ⇒ ø35	-S	X52/3A ⇒ ø35	-6	X62/3A ⇒ ø40	-7	X73/4A ⇒ ø45	-8	X83/4A ⇒ ø50	-9	X93/4C ⇒ ø65	-9	X103/4 ⇒ ø75
X22S	-F ⇒ ø40																																																																							
-A ⇒ ø18	-H ⇒ ø45																																																																							
-B ⇒ ø20	113C 114C																																																																							
X32S X33S	-F ⇒ ø40																																																																							
-B ⇒ ø20	-G ⇒ ø42																																																																							
-C ⇒ ø25	133C 134C																																																																							
X42A X43A	-F ⇒ ø40																																																																							
-C ⇒ ø25	-H ⇒ ø45																																																																							
-D ⇒ ø30	X93C X94C																																																																							
X52A X53A	-H ⇒ ø45																																																																							
-D ⇒ ø30	-J ⇒ ø50																																																																							
-E ⇒ ø35	X103 X104																																																																							
X62A X63A	-K ⇒ ø60																																																																							
-E ⇒ ø35	X113 X114																																																																							
-F ⇒ ø40	-T ⇒ ø70																																																																							
-I	X22S ⇒ ø20																																																																							
-L	X32/3S ⇒ ø25																																																																							
-M	X42/3A ⇒ ø30																																																																							
-N	X52/3A ⇒ ø35																																																																							
-V	X62/3A ⇒ ø35																																																																							
-P	X73/4A* ⇒ ø40*																																																																							
-1	133/4C ⇒ ø45*																																																																							
-3	X93/4C ⇒ ø50*																																																																							
-5	X103/4 ⇒ ø60*																																																																							
-5	X113/4 ⇒ ø70*																																																																							
-U	X22S ⇒ ø20																																																																							
-Q	X32/3S ⇒ ø30																																																																							
-R	X42/3A ⇒ ø35																																																																							
-S	X52/3A ⇒ ø35																																																																							
-6	X62/3A ⇒ ø40																																																																							
-7	X73/4A ⇒ ø45																																																																							
-8	X83/4A ⇒ ø50																																																																							
-9	X93/4C ⇒ ø65																																																																							
-9	X103/4 ⇒ ø75																																																																							

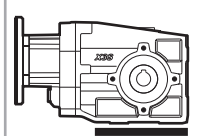
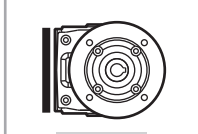
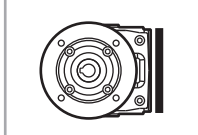
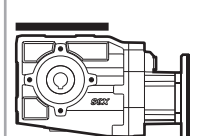
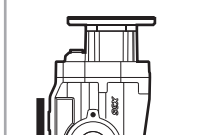
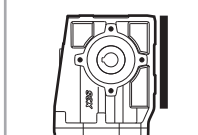
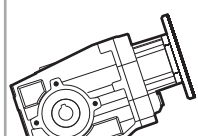
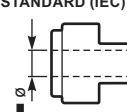
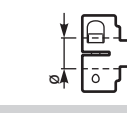
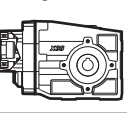

On request we can deliver our products according to the ATEX
 A richiesta possiamo fornire i nostri prodotti secondo le normative ATEX
 Auf Anfrage können wir unsere Produkte den Richtlinien ATEX entsprechend liefern
 Sur demande nos produits peuvent se conformer à la réglementation ATEX
 A pedido, se pueden enviar nuestros productos de acuerdo con las normas ATEX.

Type - Tipo - Typ Type - Tipo	Output flange Flangia di uscita Ausgangs Flansch Bride de sortie Brida en salida	Motor size - Grandezza motore Motor Größe Grandeur moteur - Tamaño motor	Mounting position Posizione montaggio Einbaulage Position de montage Position de montaje	Input bore Foro entrata Eingangshohlwelle Trou d'entree Eje hueco de entrada	Terminal box position Posizione morsettiere Klemmkastenlage Position boîte à bornes Posición caja de bornes
<p>BR</p>  <p>FB Forma base Universal</p> <p>BR Braccio di reazione Reaction arm</p> <p>-F Flangia uscita output flange</p>	<p>N</p>  <p>N Senza flangia Without flange</p> <p>X22S</p> <p>1 ⇨ $\varnothing 120$ X32S X33S</p> <p>1 ⇨ $\varnothing 120$ 2 ⇨ $\varnothing 160$ X42-3A X52-3A X62-3A</p> <p>2 ⇨ $\varnothing 160$ 3 ⇨ $\varnothing 200$ X73C X74C X83C X84C</p> <p>4 ⇨ $\varnothing 250$ 113C 114C X93C X94C</p> <p>C ⇨ $\varnothing 280$ L ⇨ $\varnothing 280$ 133C 134C</p> <p>C ⇨ $\varnothing 320$ X103 X104</p> <p>6 ⇨ $\varnothing 350$ X113 X114</p> <p>7 ⇨ $\varnothing 450$</p>	<p>-O</p> <p>Flange Flangia</p>  <p>B5</p> <p>-A=56 ($\varnothing 120$) -B=63 ($\varnothing 140$) -C=71 ($\varnothing 160$) -D=80 ($\varnothing 200$) -E=90 ($\varnothing 200$) -F=100 ($\varnothing 250$) -G=132 ($\varnothing 300$) -H=160 ($\varnothing 350$) -I=180 ($\varnothing 350$) -L=200 ($\varnothing 400$) CA=225 ($\varnothing 450$)</p> <p>B14</p> <p>-O=56 ($\varnothing 80$) -P=63 ($\varnothing 90$) -Q=71 ($\varnothing 105$) -R=80 ($\varnothing 120$) -T=90 ($\varnothing 140$) -U=100 ($\varnothing 160$) -V=132 ($\varnothing 200$)</p> <p>Brushless</p> <p>BB=50/70-M5 BC=60/75-M5 BD=70/90-M6 BE=80/100-M6 BF=95/115-M8 BG=110/145-M8 BH=130/165-M8</p> <p>Type R Tipo R</p>  <p>X22S X33S X43A</p> <p>-1 ⇨ $\varnothing 14$ X32S X42A X53A X63A X74C X84C 114C 134C</p> <p>-2 ⇨ $\varnothing 19$ X52A X62A 113C 133C X73C X83C X94C</p> <p>-3 ⇨ $\varnothing 24$ X93C X104 X114</p> <p>-4 ⇨ $\varnothing 28$ X103 X113</p> <p>-6 ⇨ $\varnothing 42$</p> <p>Without flange Senza flangia</p>  <p>-M ⇨ With coupling</p> <p>X22S X33S X43A</p> <p>-Z ⇨ $\varnothing 9$ (56B5) -0 ⇨ $\varnothing 11$ (63B5) -1 ⇨ $\varnothing 14$ (71B5)</p> <p>X32S X42A X53A X63A X74C X84C 114C 134C</p> <p>-1 ⇨ $\varnothing 14$ (71B5) -2 ⇨ $\varnothing 19$ (80B5) -3 ⇨ $\varnothing 24$ (90B5)</p> <p>X52A X62A 113C 133C X73C X83C X94C</p> <p>-2 ⇨ $\varnothing 19$ (80B5) -3 ⇨ $\varnothing 24$ (90B5) -4 ⇨ $\varnothing 28$ (100B5)</p>	<p>B3</p>  <p>B3 STANDARD</p>  <p>B6</p>  <p>B7</p>  <p>B8</p>  <p>V5</p>  <p>V6</p>  <p>V8</p>	<p>ST</p> <p>ST standard bore foro standard</p> <p>COUPLING STANDARD (IEC)</p>  <p>-A = 9mm -B = 11mm -C = 14mm -D = 19mm -E = 24mm -F = 28mm</p> <p>BRUSHLESS *</p>  <p>-2 = 11mm -3 = 14mm -4 = 19mm -5 = 22mm -6 = 24mm</p> <p>-0</p> <p>Ready for input coupling Predisposto per giunto</p>  <p>* With reduction bushing where applicable Con bussola di riduzione dove prevista</p>	<p>With Type M specify terminal box position Con tipo M specificare posizione morsettiere</p>  <p>A</p>  <p>B STANDARD</p>  <p>C</p>  <p>D</p>

POTENZA RICHIESTA / REQUIRED POWER / ERFORDERLICHE LEISTUNG / PUISSANCE NECESSAIRE / POTENCIA NECESARIA

Lifting / sollevamento / hubantriebe / levage / elevación

$$P \text{ [KW]} = \frac{M \text{ [Kg]} \cdot g \text{ [9.81]} \cdot v \text{ [m / s]}}{1000}$$

Rotation / rotazione / drehung / rotation / rotacion

$$P \text{ [KW]} = \frac{M \text{ [Nm]} \cdot n \text{ [rpm]}}{9550}$$

Linear movement / traslazione / linearbewegung / translation / translacion

$$P \text{ [KW]} = \frac{F \text{ [N]} \cdot v \text{ [m / s]}}{1000}$$

TORQUE / COPPIA / DREHMOMENT / COUPLE / PAR

$$M \text{ [Nm]} = \frac{9550 \cdot P \text{ [KW]}}{n \text{ [rpm]}}$$

$$M \text{ [lb in]} = \frac{63030 \cdot P \text{ [HP]}}{n \text{ [rpm]}}$$

RADIAL LOADS / CARICHI RADIALI / RADIALE - UND AXIALLASTEN / CHARGES RADIALES / CARGA RADIAL Y AXIAL

- Radial load generated by external transmissions keyed onto input and/or output shafts.
- Forza radiale generata da organi di trasmissione calettati sugli alberi di ingresso e/o uscita.
- Belastungen der Antriebs- bzw. Abtriebswellen durch von aussen eingebrachte Radiallasten.
- Charge radiale générée par la transmissions calés sur les entrées et / ou des arbres de sortie
- Cargas radiales, generada por transmisiones externas, aplicadas sobre los ejes de entrada y/o salida

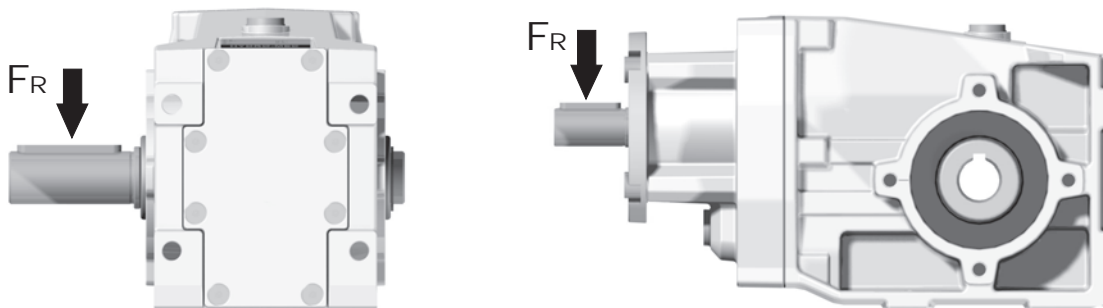

$$F_R \text{ [N]} = \frac{M \text{ [Nm]} \cdot 2000}{d \text{ [mm]}} \cdot f_k$$

$$F_R \text{ [N]} = \frac{M \text{ [lb in]} \cdot 8.9}{d \text{ [in]}} \cdot f_k$$

M	Momento torcente / Output torque / Abtriebsdrehmoment / Couple / Par torsion
d	Diametro primitivo / Diam. of driving element / Durchmesser der Abtriebseinheit / Diamètre primitif / Diámetro primitivo
f_k	Coefficiente di trasformazione / Factor / Faktor / Coefficient de transmission / Coeficiente de transmisión 1.15 Ingranaggi / Gearwheels / Zahnrad / Engrenage / Engranaje 1.25 Catena / Chain sprochets / Antriebskette / Chaîne / Cadena 1.75 Cinghia Trapezoidale / Narrow v-belt pulley / Keilriemen / Courroie trap. / Correa trapezoidal 2.50 Cinghia piatta / Flat-belt pulley / Flachzahnriem. / Courroie crantée / Correa plana

- If your application requires higher radial loads, contact our technical office. Higher load may be possible.
- Nel caso la vostra applicazione richieda carichi radiali superiori consultare il nostro ufficio tecnico, valori maggiori possono essere accettati.
- Wenn Ihre Anwendung höhere Radialbelastungen erfordert, so wenden Sie sich bitte an unser technischen Büro.
- Si votre application demande des charges radiales supérieures, s'adresser à notre bureau technique.
- En el caso en que una aplicación exija una carga radial superior a la especificada en el catálogo, consultar a nuestra oficinas técnica.

How to select a gearbox / Come selezionare un riduttore / Wie wählt man ein Getriebe
Comment sélectionner un réducteur / Cómo seleccionar un reductor

B Output speed
Velocità in uscita
Abtriebsdrehzahl
Vitesse de sortie
Velocidad de salida

Nominal power
Potenza nominale
Max. mögliche Leistung
Puissance nominale
Potencia nominal

A Nominal torque
Momento torcente nominale
Nenn Drehmoment
Couple nominal
Par de torsión nominal

Flange code
Codice flangia
Flanschttype
Code bride
Código bridas

Input speed
Velocità in entrata
Eintriebsdrehzahl
Vitesse en entrée
Velocidad de entrada

Gear size
Grandezza riduttore
Getriebegröße
Taille réducteur
Tamaño reductor

Motor power
Potenza motore
Motorleistung
Puissance moteur
Potencia motor

X22S

Angletech Gear 50Nm

Rating - Aluminum HELICAL-BEVEL GEARBOXES

QUICK SELECTION / Selezione veloce The dynamic efficiency is **0.96** for all ratios **input speed (n₁) = 1400 min⁻¹**

Output Speed n ₂ [min ⁻¹]	Ratio i	Motor power P _{1M} [kW]	Output torque M _{2M} [Nm]	Service factor f.s.	Nominal power P _{1R} [kW]	Nominal torque M _{2R} [Nm]	Available B5 motor flanges		Available B14 motor flanges			Output Shaft		
							-B	-C	-O	-P	-Q			Ratio code
289.7	4.83	0.37	11.7	2.6	0.95	30	63	71	C	C		289		01
189.2	7.40	0.37	17.9	1.7	0.62	30			C	C		287		02
146.2	9.58	0.37	23.2	1.7	0.64	40			C	C		199		03
127.5	10.98	0.37	26.6	1.7	0.63	45			C	C		179		04

C Ratio
Rapporto
Untersetzung
Rapport de réduction
Relación

Transmitted torque
Momento torcente trasmesso
Mögliche Drehmomente
Couple de sortie
Par transmitido

Service factor
Fattore di servizio
Betriebsfaktor
Facteur de service
Factor de servicio

Output shaft diam.
Diam. albero uscita
Durchmesser abtriebswelle
Diametre arbre lent
Diametro eje de salida

Notes
Note
Anmerkungen
Note
Notas

Type of load and starts per hour Tipo di carico e avviamenti per ora		Oper. hours per day Ore di funz. giorn.		
		3 h	10 h	24 h
Continuous or intermittent appl. with start / hour Applicazione cont. o interm. con n.ro operazioni/ora	Uniform / Uniforme	0.8	1	1.25
	Moderate / Moderato	1	1.25	1.5
	Heavy / Forte	1.25	1.5	1.75
Intermittent application with start / hour Applicazione intermittente con n.ro operazioni/ora	Uniform / Uniforme	1	1.25	1.5
	Moderate / Moderato	1.25	1.5	1.75
	Heavy / Forte	1.5	1.75	2.15

D Motor flange available
Flange disponibili
Erhältliche Motorflansche
Bridas disponibles
Bridas disponibles

B) Mounting with reduction ring
Montaggio con boccia di riduzione
Reduzierhülsen
Montage avec douille de réduction
Montaje con casquillo de reducción

C) Motor flangeholes position/terminal box position
Posizione fori flangia/basetta motore
Bohrungsposition am Motorflansch/-socket
Position trous bride/barrette à bornes moteur
Posición agujeros brida / base motor

B) Available without reduction bushes
Disponibile anche senza boccia
Auch ohne Reduzierbuchse verfügbar
Disponible aussi sans douille de réduction
Disponible también sin casquillo

A	Select required torque (according to service factor)	Seleziona la coppia desiderata (comprensiva del fattore di servizio)	Max. Drehmoment in Bezug zum Betriebsfaktor	Sélectionner le couple souhaité (comprenant le facteur de service)	Seleccionar el par deseado (incluyendo el factor de servicio)
B	Select output speed	Seleziona la velocità in uscita	Ausgewählte Abtriebsdrehzahl	Sélectionner la vitesse de sortie	Seleccionar la velocidad de salida
C	On the same line of selected geared motor, you can find the gear ratio	Sulla riga corrispondente alla motorizzazione prescelta si può rilevare il rapporto di riduzione	Auf der gleichen Linie wie die ausgewählte Motorleistung steht auch die Getriebeuntersetzung	Sur la ligne correspondante à la motorisation pré-choisie on peut relever le rapport de réduction	En la línea correspondiente al motor preseleccionado es posible encontrar la relación de reducción
D	Select motor flange available (if requested)	Scegli la flangia disponibile (se richiesta)	Erhältliche Motorflansche (auf Anfrage)	Choisir la bride disponible (si elle est demandée)	Seleccionar la brida disponible (sobre pedido)

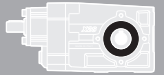

QUICK SELECTION / Selezione veloce

The dynamic efficiency is **0.96** for all ratios **input speed (n₁) = 1400 min⁻¹**

Output Speed n ₂ [min ⁻¹]	Ratio i	Motor power P _{1M} [kW]	Output torque M _{2M} [Nm]	Service factor f.s.	Nominal power P _{1R} [kW]	Nominal torque M _{2R} [Nm]	Available B5 motor flanges		Available B14 motor flanges			Output Shaft 	Ratios code		
							-B	-C	-O	-P	-Q				
							63	71	56	63	71				
290	4.83	0.37	12	2.6	0.95	30			C	C		289	standard ø20	01	
189	7.40	0.37	18	1.7	0.62	30			C	C		287		02	
146	9.58	0.37	23	1.7	0.64	40			C	C		199		03	
128	10.98	0.37	27	1.7	0.63	45			C	C		179		04	
107	13.07	0.37	32	1.4	0.53	45			C	C		159		05	
95	14.66	0.37	35	1.3	0.47	45			C	C		197		06	
89	15.79	0.37	38	1.2	0.44	45			C	C		139		07	
83	16.81	0.37	41	1.1	0.41	45			C	C		177		08	
70	20.00	0.37	48	1.0	0.37	48			C	C		157		09	
64	21.93	0.37	53	0.9	0.35	50			C	C		109		On request	10
58	24.18	0.25	39	1.3	0.32	50			C	C		137		11	
48.2	29.04	0.25	47	1.1	0.26	50			C	C		99		12	
41.7	33.57	0.18	42	1.2	0.23	50			C	C		107		13	
36.2	38.67	0.18	48	1.0	0.20	50			C	C		79		14	
31.5	44.44	0.18	55	0.9	0.17	50			C	C		97		15	
23.7	59.18	0.12	48	1.0	0.13	50			C	C		77		16	
19.9	70.24	0.09	45	1.1	0.11	50			C	C		67		17	

 Motor Flanges Available Flange Motore Disponibili
 B) Supplied with Reduction Bushing Fornito con Bussola di Riduzione
 B) Available on Request without reduction bushing Disponibile a Richiesta senza Bussola di Riduzione
 C) Motor Flange Holes Position Posizione Fori Flangia Motore

EN Unit **X22S** is supplied with synthetic oil for lifetime lubrication, no maintenance is necessary. See table 1 for lubrication and recommended quantity. In table 2 please see possible radial loads and axial loads on the gearbox.

I Il riduttore **X22S** viene fornito completo di olio sintetico per la lubrificazione permanente e non necessita di alcuna manutenzione. Vedi tab.1 per oli e quantità consigliati. In tab.2 sono presenti i carichi radiali e assiali applicabili al riduttore.

D Das Getriebe **X22S** ist mit synthetischem Öl gefüllt und ist lebensdauer geschmiert. In Tabelle 1 ist die Schmiermenge und das empfohlene Schmiermittel angegeben. In Tabelle 2 sind die zulässigen Radial - und Axialbelastungen des Getriebes aufgeführt.

F Le réducteur **X22S** est fourni complet avec de l'huile synthétique pour la lubrification permanente et ne nécessite aucun entretien. Voir tableau 1 concernant les huiles et les quantités conseillées. Les charges radiales et axiales applicables au réducteur sont précisées dans le tableau 2.

E El reductor tamaño **X22S** se suministra, lubricado de por vida con aceite sintético y no requieren mantenimiento alguna. Ver tabla 1, para cantidades y aceites recomendados. En la tabla 2, se encuentran las cargas radiales y axiales admitidas por el reductor.

Standard supplied	For these mounting position specify in the order or add oil					
	Per queste posizioni specificare in fase d'ordine o aggiungere olio					
B3	B6	B7	B8	V5	V6	V8
0.25 LT	0.25 LT	0.25 LT	0.25 LT	0.43 LT	0.31 LT	Ask
SHELL Omala S4 WE 320				ENI Telium VSF 320		

For all details on lubrication and plugs check our website **tab. 1**
Per maggiori dettagli su lubrificazione e tappi olio vedi il nostro sito web

RADIAL AND AXIAL LOADS

Output shaft
Albero di uscita

$F_{eq} = F_R \cdot \frac{101}{X+82}$

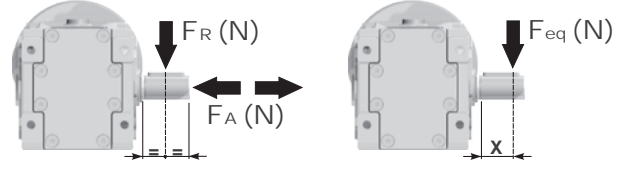

n ₂ [min ⁻¹]	FA	FR	n ₂ [min ⁻¹]	FA	FR	n ₂ [min ⁻¹]	FA	FR
400	360	1800	100	440	2200	25	440	2200
250	380	1900	75	440	2200	15	440	2200
150	420	2100	50	440	2200			

F_R On request taper roller bearings to increase radial loads.
A richiesta cuscinetti a rulli conici per aumentare i carichi radiali.

Input shaft
albero in entrata

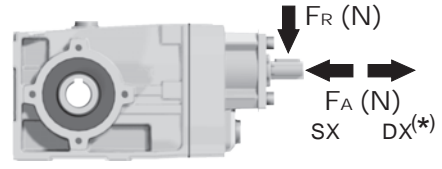

n ₁ [min ⁻¹]	FA	FR
1400	140	700
900	160	800
500	190	950

***Strong axial loads in the DX direction are not allowed.**
Non sono consentiti forti carichi assiali con direzione DX

tab. 2

PX22SC... Basic Gearbox
Riduttore base

Gearbox weight 3.70 kg
peso riduttore

M. flanges	Kit code	øF	A
63B5	K050.4.041	138	154.5
71B5	K050.4.042	160	152
56B14	KC40.4.049	80	152
63B14	K050.4.047	90	154.5
71B14	K050.4.045	105	152

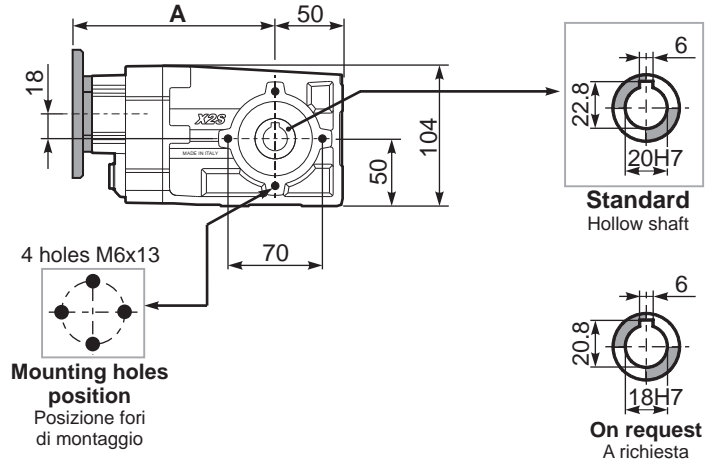
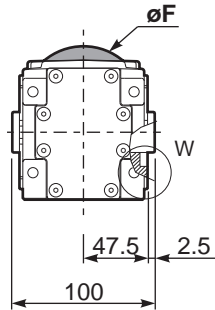
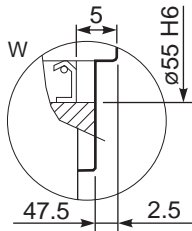

Mounting holes position
Posizione fori di montaggio

PX22S...FB.. Feet
Piedini

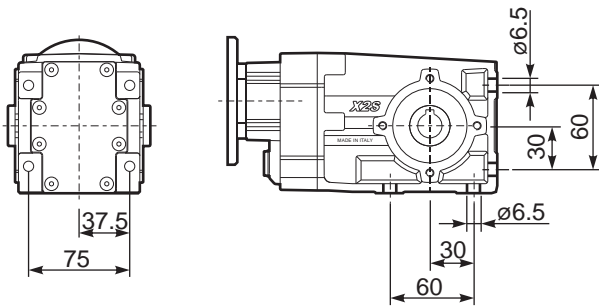

PX22S...-F1.. Output flange
Flangia uscita

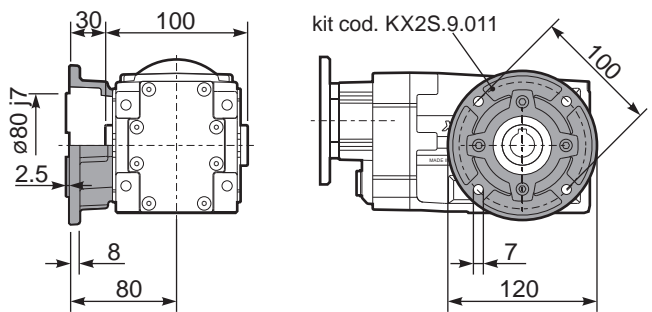

PX22SA.. Single output shaft
Albero semplice in uscita

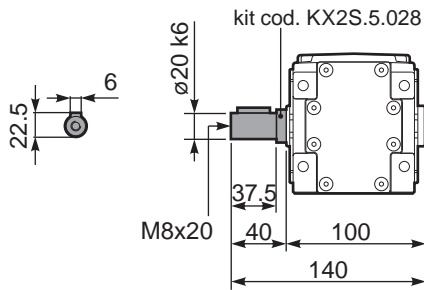

PX22S...BR.. Reaction Arm
Braccio di reazione

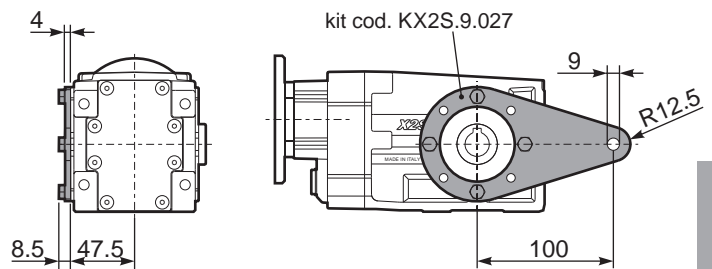

RX22S.. Input shaft
Albero in entrata

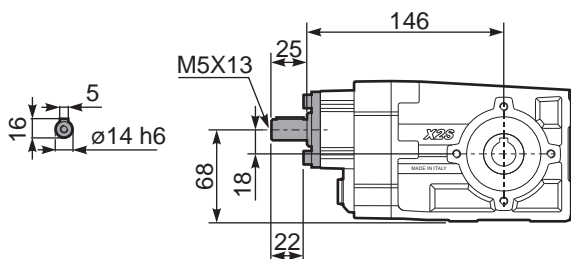

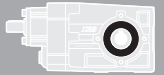

QUICK SELECTION / Selezione veloce The dynamic efficiency is **0.96** for all ratios **input speed (n₁) = 1400 min⁻¹**

Output Speed n ₂ [min ⁻¹]	Ratio i	Motor power P _{1M} [kW]	Output torque M _{2M} [Nm]	Service factor f.s.	Nominal power P _{1R} [kW]	Nominal torque M _{2R} [Nm]	Available B5 motor flanges				Available B14 motor flanges			Output Shaft 	Ratios code	
							-B	-C	-D	-E	-Q	-R	-T			
							63	71	80	90	71	80	90			
191	7.33	1.5	72	1.0	1.5	70	B				C	C		289	standard ø20	01
125	11.22	1.1	80	1.1	1.2	85	B				C	C		287		02
106	13.26	1.1	95	0.9	0.98	85	B				C	C		199		03
91	15.37	1.1	110	0.8	0.89	90	B				C	C		179		04
78	18.04	0.75	89	1.0	0.76	90	B				C	C		159		05
69	20.30	0.75	100	0.9	0.68	90	B				C	C		197		06
65	21.54	0.75	106	0.9	0.64	90	B				C	C		139		07
59	23.53	0.55	85	1.1	0.58	90	B				C	C		177		08
51	27.62	0.55	100	0.9	0.50	90	B				C	C		157		09
47.6	29.40	0.55	106	0.8	0.47	90	B				C	C		109		On request
42.5	32.97	0.37	80	1.1	0.42	90	B				C	C		137	11	
36.5	38.37	0.37	93	1.0	0.36	90	B				C	C		99	12	
31.1	45.00	0.25	73	1.2	0.31	90	B				C	C		107	13	
27.6	50.67	0.25	83	1.1	0.27	90	B				C	C		79	14	
23.8	58.73	0.18	73	1.2	0.23	90	B				C	C		97	15	
18.1	77.55	0.18	97	0.9	0.18	90	B				C	C		77	16	

Motor Flanges Available Flange Motore Disponibili
 B) Supplied with Reduction Bushing Fornito con Bussola di Riduzione
 B) Available on Request without reduction bushing Disponibile a Richiesta senza Bussola di Riduzione
 C) Motor Flange Holes Position Posizione Fori Flangia Motore

EN Unit **X32S** is supplied with synthetic oil for lifetime lubrication, no maintenance is necessary. See table 1 for lubrication and recommended quantity. In table 2 please see possible radial loads and axial loads on the gearbox.

I Il riduttore **X32S** viene fornito completo di olio sintetico per la lubrificazione permanente e non necessita di alcuna manutenzione. Vedi tab.1 per oli e quantità consigliati. In tab.2 sono presenti i carichi radiali e assiali applicabili al riduttore.

D Das Getriebe **X32S** ist mit synthetischem Öl gefüllt und ist lebensdauer geschmiert. In Tabelle 1 ist die Schmiermenge und das empfohlene Schmiermittel angegeben. In Tabelle 2 sind die zulässigen Radial - und Axialbelastungen des Getriebes aufgeführt.

F Le réducteur **X32S** est fourni complet avec de l'huile synthétique pour la lubrification permanente et ne nécessite aucun entretien. Voir tableau 1 concernant les huiles et les quantités conseillées. Les charges radiales et axiales applicables au réducteur sont précisées dans le tableau 2.

E El reductor tamaño **X32S** se suministra, lubricado de por vida con aceite sintético y no requieren mantenimiento alguna. Ver tabla 1, para cantidades y aceites recomendados. En la tabla 2, se encuentran las cargas radiales y axiales admitidas por el reductor.

Standard supplied	For these mounting position specify in the order or add oil Per queste posizioni specificare in fase d'ordine o aggiungere olio					
B3	B6	B7	B8	V5	V6	V8
0.40 LT	0.60 LT	0.40 LT	0.60 LT	0.85 LT	0.60 LT	Ask
SHELL Omala S4 WE 320				ENI Telium VSF 320		

For all details on lubrication and plugs check our website **tab. 1**
Per maggiori dettagli su lubrificazione e tappi olio vedi il nostro sito web

• RADIAL AND AXIAL LOADS

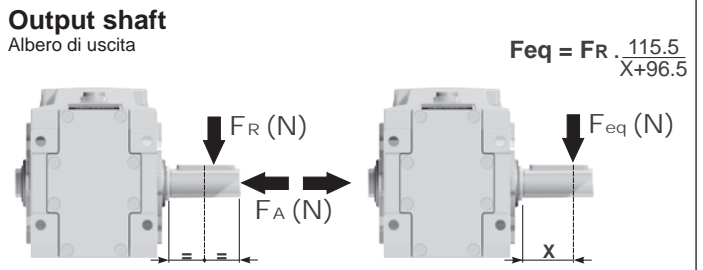

n ₂ [min ⁻¹]	FA	FR	n ₂ [min ⁻¹]	FA	FR	n ₂ [min ⁻¹]	FA	FR
250	400	2000	75	560	2800	15	560	2800
150	450	2250	50	560	2800			
100	500	2500	25	560	2800			

F_R On request taper roller bearings to increase radial loads.
A richiesta cuscinetti a rulli conici per aumentare i carichi radiali.

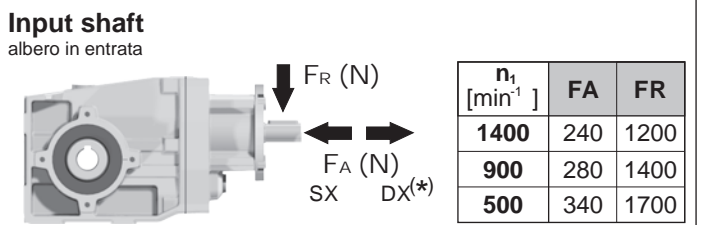

*Strong axial loads in the DX direction are not allowed.
Non sono consentiti forti carichi assiali con direzione DX

tab. 2

PX32SC... Basic Gearbox
Riduttore base

Gearbox weight **6.30 kg**
peso riduttore

M. flanges	Kit code	øF	A
63B5	K063.4.041	140	184
71B5	K063.4.042	160	182
80/90B5	K063.4.043	200	184
71B14	K063.4.047	105	182
80B14	K063.4.046	120	184
90B14	K063.4.041	140	184

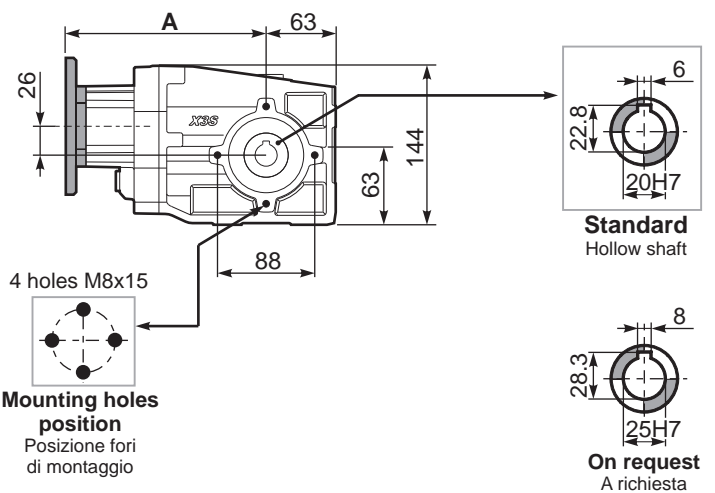
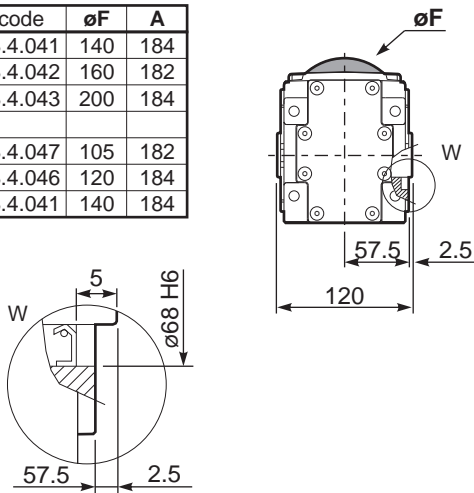

PX32S...FB.. Feet
Piedini

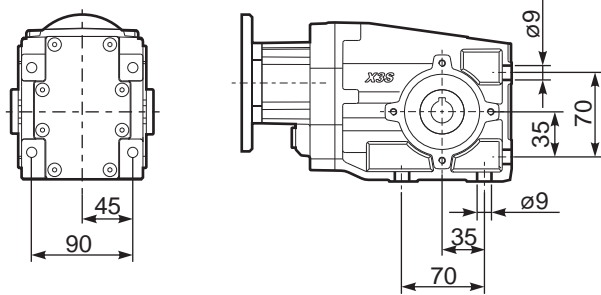

PX32S...-F1.. Output flange
Flangia uscita

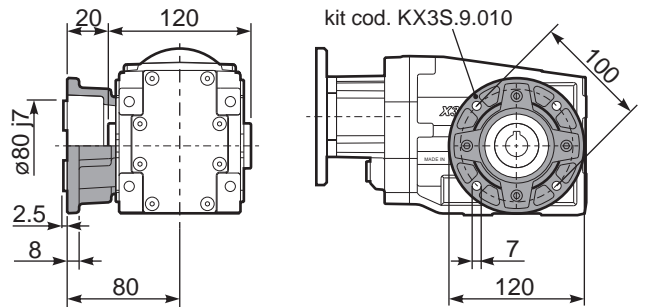

PX32S...-F2.. Output flange
Flangia uscita

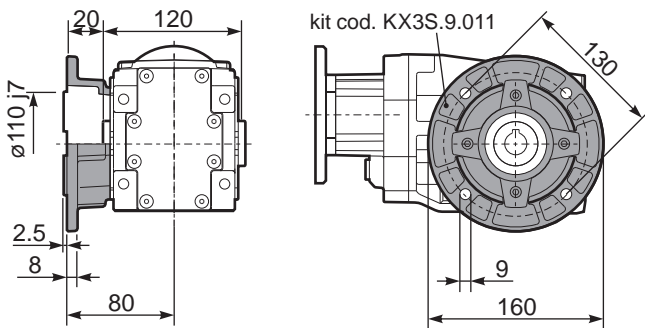

PX32S...BR.. Reaction Arm
Braccio di reazione

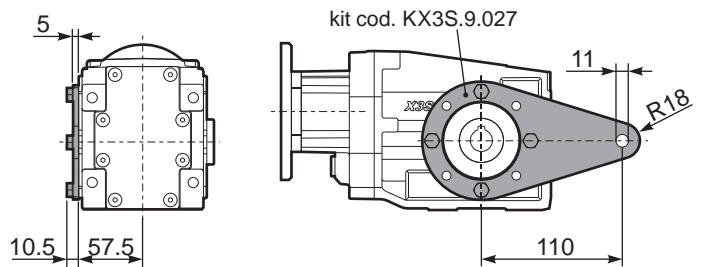

RX32S... Input shaft
Albero in entrata

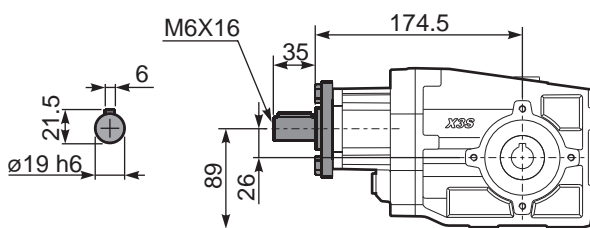

PX32SA.. Single output shaft
Albero semplice in uscita

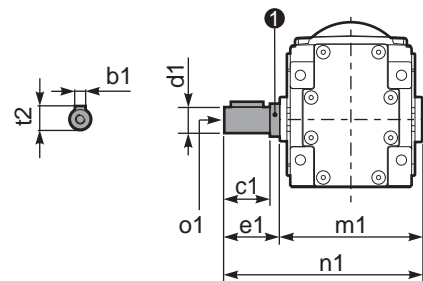

d1	b1	c1	e1	m1	n1	t2	o1	① kit code
ø20 k6	6	37.5	40	120	160	22.5	M8x20	KX2S.5.028
ø25 ^{-0.005} _{-0.020}	8	60	63.2	126.8	190	28	M8x20	K063.5.028

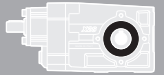

QUICK SELECTION / Selezione veloce The dynamic efficiency is **0.94** for all ratios **input speed (n₁) = 1400 min⁻¹**

Output Speed n ₂ [min ⁻¹]	Ratio i	Motor power P _{1M} [kW]	Output torque M _{2M} [Nm]	Service factor f.s.	Nominal power P _{1R} [kW]	Nominal torque M _{2R} [Nm]	Available B5 motor flanges		Available B14 motor flanges			Output Shaft 	Ratios code
							-B	-C	-O	-P	-Q		
							63	71	56	63	71		
38.7	36.17	0.37	86	1.2	0.43	100			C	C		17179	02
31.7	44.21	0.37	105	1.0	0.35	100			C	C		19139	03
27.6	50.68	0.25	81	1.2	0.31	100			C	C		17139	04
25.3	55.36	0.25	89	1.1	0.28	100			C	C		17177	05
23.2	60.31	0.25	96	1.0	0.26	100			C	C		15139	06
21.2	65.88	0.25	105	0.9	0.24	100			C	C		15177	07
19.4	72.25	0.18	88	1.1	0.22	100			C	C		10179	standard 08
17.6	79.64	0.18	97	1.0	0.20	100			C	C		13177	09
15.2	92.31	0.18	113	0.9	0.17	100			C	C		15137	10
14.6	95.65	0.18	117	0.9	0.16	100			C	C		9179	11
13.8	101.23	0.12	80	1.2	0.15	100			C	C		10139	12
11.0	127.37	0.12	101	1.0	0.12	100			C	C		7179	On request 13
9.3	151.16	0.09	95	1.0	0.10	100			C	C		6179	14
7.8	178.46	0.09	113	0.9	0.09	100			C	C		7139	15
6.6	211.79	0.06	88	1.1	0.07	100			C	C		6139	16
6.1	231.37	0.06	96	1.0	0.07	100			C	C		6177	17
5.1	273.16	0.06	113	0.9	0.06	100			C	C		7137	18
4.3	324.18	0.06	134	0.7	0.05	100			C	C		6137	19

Motor Flanges Available Flange Motore Disponibili
B) Supplied with Reduction Bushing Fornito con Bussola di Riduzione
B) Available on Request without reduction bushing Disponibile a Richiesta senza Bussola di Riduzione
C) Motor Flange Holes Position Posizione Fori Flangia Motore

EN Unit **X33S** is supplied with synthetic oil for lifetime lubrication, no maintenance is necessary. See table 1 for lubrication and recommended quantity. In table 2 please see possible radial loads and axial loads on the gearbox.

I Il riduttore **X33S** viene fornito completo di olio sintetico per la lubrificazione permanente e non necessita di alcuna manutenzione. Vedi tab.1 per oli e quantità consigliati. In tab.2 sono presenti i carichi radiali e assiali applicabili al riduttore.

D Das Getriebe **X33S** ist mit synthetischem Öl gefüllt und ist lebensdauergeschmiert. In Tabelle 1 ist die Schmiermenge und das empfohlene Schmiermittel angegeben. In Tabelle 2 sind die zulässigen Radial - und Axialbelastungen des Getriebes aufgeführt.

F Le réducteur **X33S** est fourni complet avec de l'huile synthétique pour la lubrification permanente et ne nécessite aucun entretien. Voir tableau 1 concernant les huiles et les quantités conseillées. Les charges radiales et axiales applicables au réducteur sont précisées dans le tableau 2.

E El reductor tamaño **X33S** se suministra, lubricado de por vida con aceite sintético y no requieren mantenimiento alguna. Ver tabla 1, para cantidades y aceites recomendados. En la tabla 2, se encuentran las cargas radiales y axiales admitidas por el reductor.

Standard supplied	For these mounting position specify in the order or add oil					
	Per queste posizioni specificare in fase d'ordine o aggiungere olio					
B3	B6	B7	B8	V5	V6	V8
0.70 LT	0.65 LT	0.40 LT	0.65 LT	0.95 LT	0.65 LT	Ask
SHELL Omala S4 WE 320				ENI Telium VSF 320		

For all details on lubrication and plugs check our website **tab. 1**
Per maggiori dettagli su lubrificazione e tappi olio vedi il nostro sito web

• RADIAL AND AXIAL LOADS

Output shaft

Albero di uscita

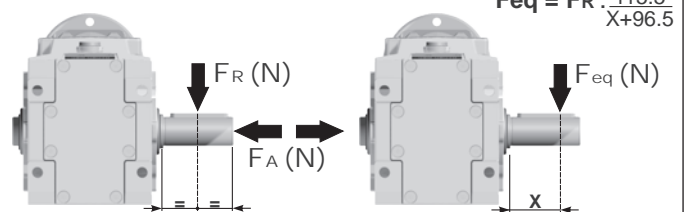

n ₂ [min ⁻¹]	FA	FR	n ₂ [min ⁻¹]	FA	FR	n ₂ [min ⁻¹]	FA	FR
250	400	2000	75	560	2800	15	560	2800
150	450	2250	50	560	2800			
100	500	2500	25	560	2800			

F_R On request taper roller bearings to increase radial loads.
A richiesta cuscinetti a rulli conici per aumentare i carichi radiali.

Input shaft

albero in entrata

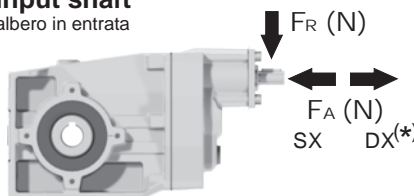

n ₁ [min ⁻¹]	FA	FR
1400	140	700
900	160	800
500	190	950

***Strong axial loads in the DX direction are not allowed.**
Non sono consentiti forti carichi assiali con direzione DX

tab. 2

PX33SC... Basic Gearbox
Riduttore base

Gearbox weight **6.55 kg**
peso riduttore

M. flanges	Kit code	øF	A
63B5	K050.4.041	138	189.5
71B5	K050.4.042	160	187
56B14	KC40.4.049	80	187
63B14	K050.4.047	90	189.5
71B14	K050.4.045	105	187

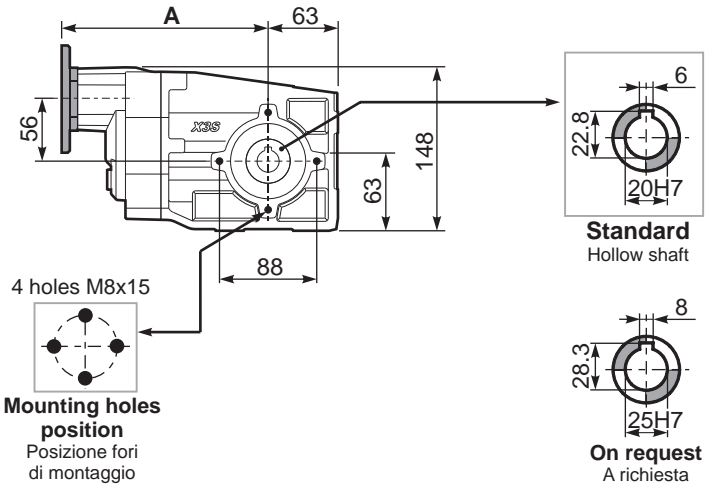
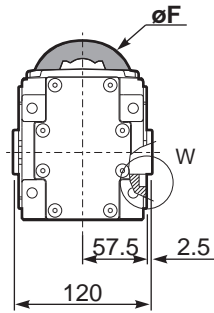
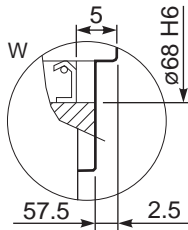

4 holes M8x15
Mounting holes position
Posizione fori di montaggio

PX33S...FB.. Feet
Piedini

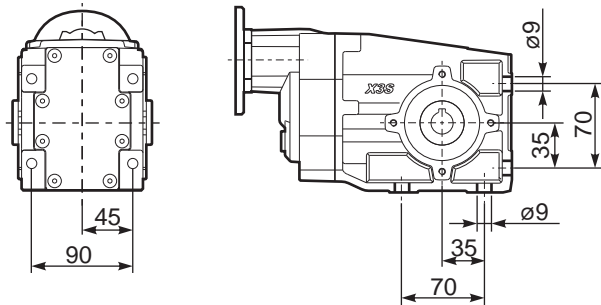

PX33S...-F1.. Output flange
Flangia uscita

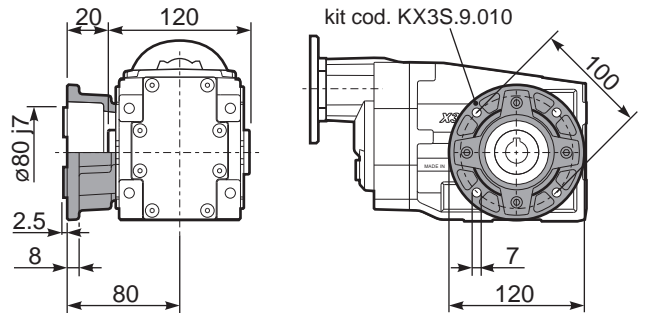

PX33S...-F2.. Output flange
Flangia uscita

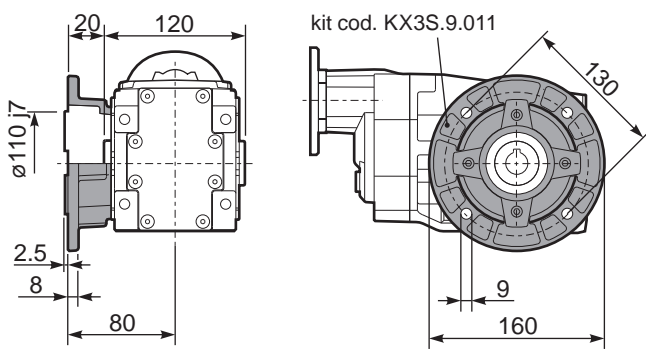

PX33S...BR.. Reaction Arm
Braccio di reazione

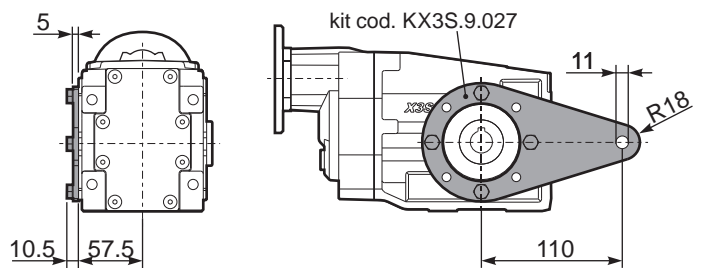

RX33S... Input shaft
Albero in entrata

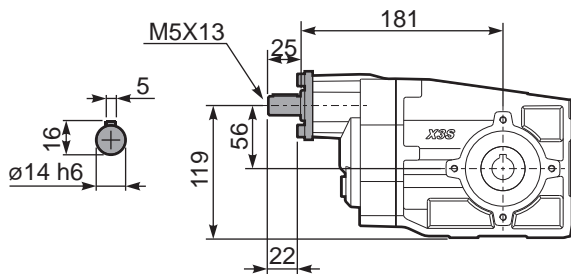

PX33SA.. Single output shaft
Albero semplice in uscita

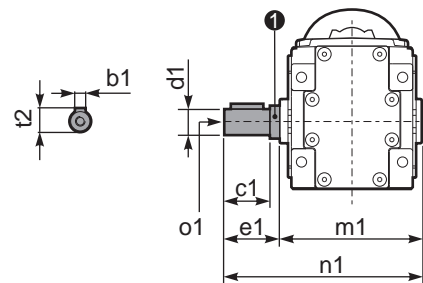

d1	b1	c1	e1	m1	n1	t2	ø1	① kit code
ø20 k6	6	37.5	40	120	160	22.5	M8x20	KX2S.5.028
ø25 ^{-0.005} _{-0.020}	8	60	63.2	126.8	190	28	M8x20	K063.5.028

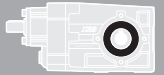

QUICK SELECTION / Selezione veloce The dynamic efficiency is **0.96** for all ratios **input speed (n₁) = 1400 min⁻¹**

Output Speed n ₂ [min ⁻¹]	Ratio i	Motor power P _{1M} [kW]	Output torque M _{2M} [Nm]	Service factor f.s.	Nominal power P _{1R} [kW]	Nominal torque M _{2R} [Nm]	Available B5 motor flanges					Available B14 motor flanges				Output Shaft 	Ratios code
							-B	-C	-D	-E	-F	-Q	-R	-T	-U		
							63	71	80	90	100	112	71	80	90		
192	7.29	2.2	104	0.9	2.0	95	B					C	C			2811	01
125	11.20	2.2	159	0.9	2.0	150	B					C	C			288	02
106	13.18	1.5	129	1.2	1.7	150	B					C	C			1911	03
92	15.27	1.1	109	1.4	1.5	150	B					C	C			1711	04
78	17.93	1.1	128	1.2	1.3	150	B					C	C			1511	05
69	20.25	1.1	145	1.0	1.1	150	B					C	C			198	06
65	21.40	1.1	153	1.0	1.1	150	B					C	C			1311	07
60	23.47	0.75	115	1.3	0.98	150	B					C	C			178	08
51	27.55	0.75	135	1.1	0.83	150	B					C	C			158	09
47.9	29.21	0.75	143	1.0	0.78	150	B					C	C			1011	10
42.6	32.88	0.75	161	0.9	0.70	150	B					C	C			138	11
36.7	38.12	0.55	138	1.1	0.60	150	B					C	C			911	12
31.2	44.89	0.55	163	0.9	0.51	150	B					C	C			108	13
27.8	50.34	0.37	122	1.1	0.40	131	B					C	C			711	14
23.9	58.58	0.37	142	1.1	0.39	150	B					C	C			98	15
18.1	77.36	0.25	126	1.2	0.30	150	B					C	C			78	16

 Motor Flanges Available Flange Motore Disponibili
 B) Supplied with Reduction Bushing Fornito con Bussola di Riduzione
 B) Available on Request without reduction bushing Disponibile a Richiesta senza Bussola di Riduzione
 C) Motor Flange Holes Position Posizione Fori Flangia Motore

EN Unit **X42A** is supplied with synthetic oil for lifetime lubrication, no maintenance is necessary. See table 1 for lubrication and recommended quantity. In table 2 please see possible radial loads and axial loads on the gearbox.

I Il riduttore **X42A** viene fornito completo di olio sintetico per la lubrificazione permanente e non necessita di alcuna manutenzione. Vedi tab.1 per oli e quantità consigliati. In tab.2 sono presenti i carichi radiali e assiali applicabili al riduttore.

D Das Getriebe **X42A** ist mit synthetischem Öl gefüllt und ist lebensdauergeschmiert. In Tabelle 1 ist die Schmiermenge und das empfohlene Schmiermittel angegeben. In Tabelle 2 sind die zulässigen Radial - und Axialbelastungen des Getriebes aufgeführt.

F Le réducteur **X42A** est fourni complet avec de l'huile synthétique pour la lubrification permanente et ne nécessite aucun entretien. Voir tableau 1 concernant les huiles et les quantités conseillées. Les charges radiales et axiales applicables au réducteur sont précisées dans le tableau 2.

E El reductor tamaño **X42A** se suministra, lubricado de por vida con aceite sintético y no requieren mantenimiento alguna. Ver tabla 1, para cantidades y aceites recomendados. En la tabla 2, se encuentran las cargas radiales y axiales admitidas por el reductor.

Standard supplied	For these mounting position specify in the order or add oil Per queste posizioni specificare in fase d'ordine o aggiungere olio					
0.60 LT	0.75 LT	0.50 LT	0.70 LT	1.10 LT	0.60 LT	Ask
SHELL Omala S4 WE 320				ENI Telium VSF 320		

For all details on lubrication and plugs check our website **tab. 1**
Per maggiori dettagli su lubrificazione e tappi olio vedi il nostro sito web

RADIAL AND AXIAL LOADS

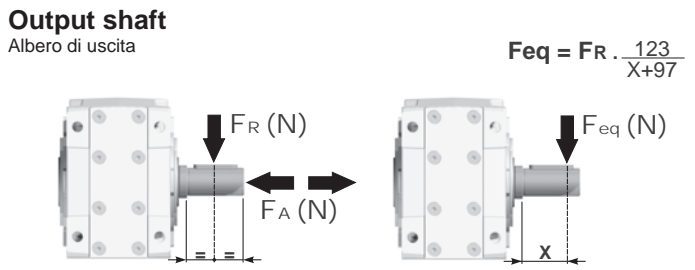

n ₂ [min ⁻¹]	FA	FR	n ₂ [min ⁻¹]	FA	FR	n ₂ [min ⁻¹]	FA	FR
250	500	2500	75	800	4000	15	960	4800
150	600	3000	50	960	4800			
100	700	3500	25	960	4800			

F_R On request taper roller bearings to increase radial loads.
A richiesta cuscinetti a rulli conici per aumentare i carichi radiali.

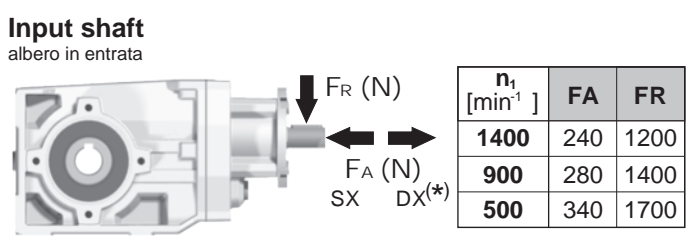

***Strong axial loads in the DX direction are not allowed.**
Non sono consentiti forti carichi assiali con direzione DX

tab. 2

PX42AC... Basic Gearbox
Riduttore base

Gearbox weight **7.82 kg**
peso riduttore

M. flanges	Kit code	∅F	A
63B5	K063.4.041	140	199.5
71B5	K063.4.042	160	197.5
80/90B5	K063.4.043	200	199.5
100/112B5	KC40.4.043	250	214.3
71B14	K063.4.047	105	197.5
80B14	K063.4.046	120	199.5
90B14	K063.4.041	140	199.5
100/112B14	KC40.4.041	160	214.5

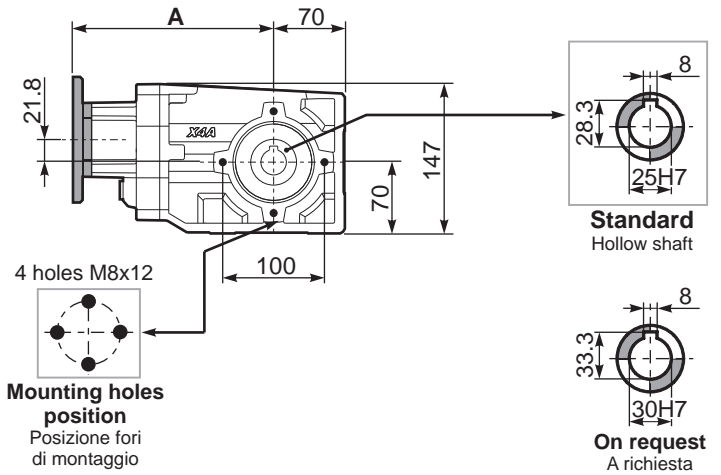
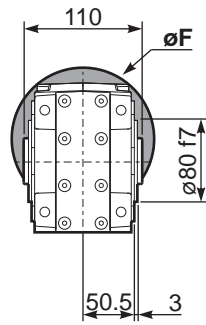

PX42A...FB.. Feet
Piedini

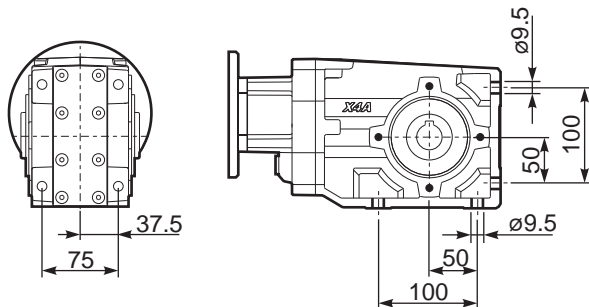

PX42A...-F2.. Output flange
Flangia uscita

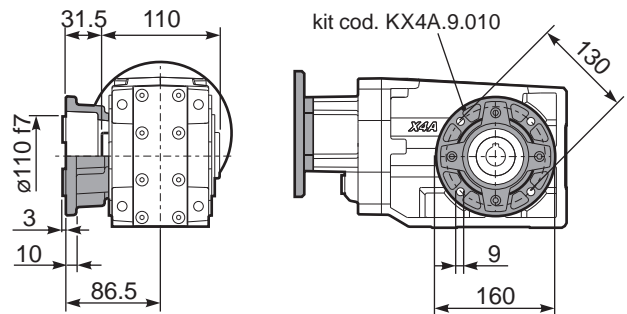

PX42A...-F3.. Output flange
Flangia uscita

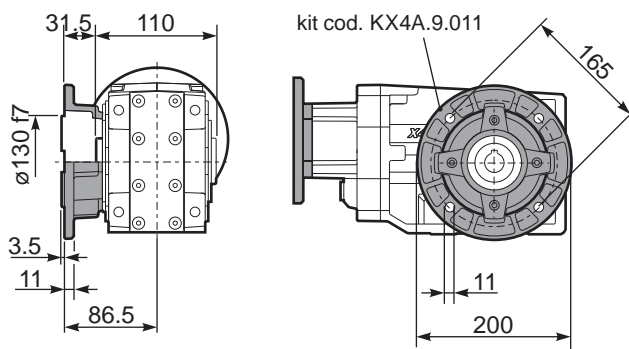

PX42A...BR.. Reaction Arm
Braccio di reazione

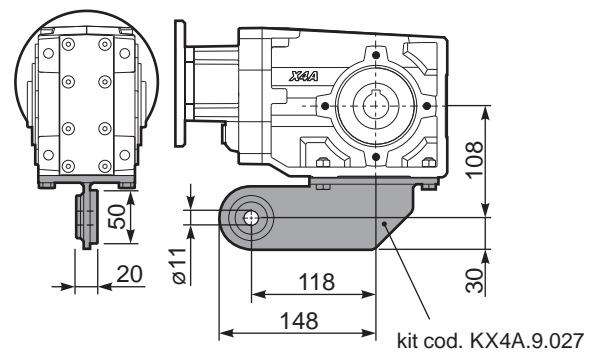

RX42A... Input shaft
Albero in entrata

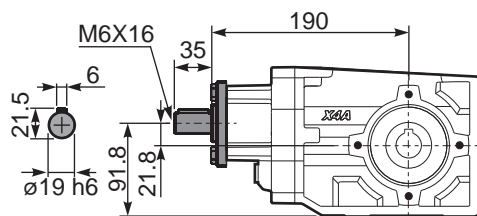

PX42A... Single output shaft
Albero semplice in uscita

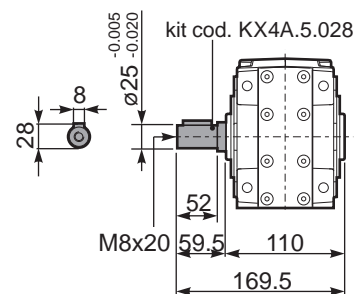

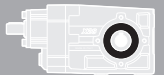

QUICK SELECTION / Selezione veloce The dynamic efficiency is **0.94** for all ratios **input speed (n₁) = 1400 min⁻¹**

Output Speed n ₂ [min ⁻¹]	Ratio i	Motor power P _{1M} [kW]	Output torque M _{2M} [Nm]	Service factor f.s.	Nominal power P _{1R} [kW]	Nominal torque M _{2R} [Nm]	Available B5 motor flanges		Available B14 motor flanges			Output Shaft 	Ratios code
							-B	-C	-O	-P	-Q		
							63	71	56	63	71		
27.8	50.35	0.37	119	1.3	0.46	150			C	C		171311	01
25.4	55.22	0.37	131	1.1	0.42	150			C	C		17178	02
23.4	59.92	0.37	142	1.1	0.39	150			C	C		151311	03
21.3	65.72	0.37	156	1.0	0.36	150			C	C		15178	04
19.5	71.78	0.25	115	1.3	0.33	150			C	C		101711	05
17.6	79.44	0.25	127	1.2	0.29	150			C	C		13178	06
15.2	92.08	0.25	147	1.0	0.25	150			C	C		15138	07
14.7	95.03	0.25	152	1.0	0.25	150			C	C		91711	08
11.1	126.55	0.18	155	1.0	0.20	160			C	C		71711	09
10.5	133.15	0.18	163	1.0	0.19	160			C	C		91311	10
9.3	150.18	0.12	119	1.3	0.17	160			C	C		61711	11
7.9	177.30	0.12	140	1.1	0.14	160			C	C		71311	12
6.7	210.42	0.09	133	1.2	0.12	160			C	C		61311	13
6.1	230.79	0.09	146	1.1	0.11	160			C	C		6178	14
5.1	272.47	0.06	113	1.4	0.09	160			C	C		7138	15
4.3	323.37	0.06	134	1.2	0.08	160			C	C		6138	16

Motor Flanges Available Flange Motore Disponibili
 Supplied with Reduction Bushing Fornito con Bussola di Riduzione
 Available on Request without reduction bushing Disponibile a Richiesta senza Bussola di Riduzione
 Motor Flange Holes Position Posizione Fori Flangia Motore

EN Unit **X43A** is supplied with synthetic oil for lifetime lubrication, no maintenance is necessary. See table 1 for lubrication and recommended quantity. In table 2 please see possible radial loads and axial loads on the gearbox.

I Il riduttore **X43A** viene fornito completo di olio sintetico per la lubrificazione permanente e non necessita di alcuna manutenzione. Vedi tab.1 per oli e quantità consigliati. In tab.2 sono presenti i carichi radiali e assiali applicabili al riduttore.

D Das Getriebe **X43A** ist mit synthetischem Öl gefüllt und ist lebensdauergeschmiert. In Tabelle 1 ist die Schmiermenge und das empfohlene Schmiermittel angegeben. In Tabelle 2 sind die zulässigen Radial - und Axialbelastungen des Getriebes aufgeführt.

F Le réducteur **X43A** est fourni complet avec de l'huile synthétique pour la lubrification permanente et ne nécessite aucun entretien. Voir tableau 1 concernant les huiles et les quantités conseillées. Les charges radiales et axiales applicables au réducteur sont précisées dans le tableau 2.

E El reductor tamaño **X43A** se suministra, lubricado de por vida con aceite sintético y no requieren mantenimiento alguna. Ver tabla 1, para cantidades y aceites recomendados. En la tabla 2, se encuentran las cargas radiales y axiales admitidas por el reductor.

Standard supplied	For these mounting position specify in the order or add oil					
	Per queste posizioni specificare in fase d'ordine o aggiungere olio					
0.80 LT	0.80 LT	0.60 LT	0.80 LT	1.20 LT	0.70 LT	Ask
SHELL Omala S4 WE 320			ENI Telium VSF 320			

For all details on lubrication and plugs check our website **tab. 1**
Per maggiori dettagli su lubrificazione e tappi olio vedi il nostro sito web

RADIAL AND AXIAL LOADS

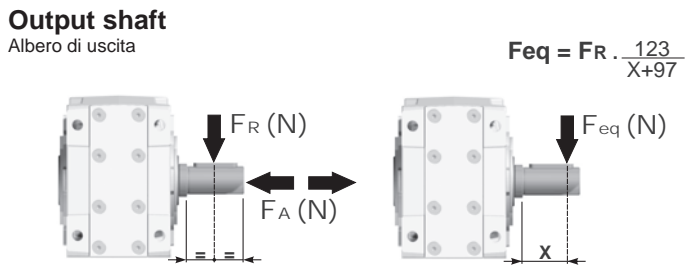

n ₂ [min ⁻¹]	FA	FR	n ₂ [min ⁻¹]	FA	FR	n ₂ [min ⁻¹]	FA	FR
250	500	2500	75	800	4000	15	960	4800
150	600	3000	50	960	4800			
100	700	3500	25	960	4800			

F_R On request taper roller bearings to increase radial loads.
A richiesta cuscinetti a rulli conici per aumentare i carichi radiali.

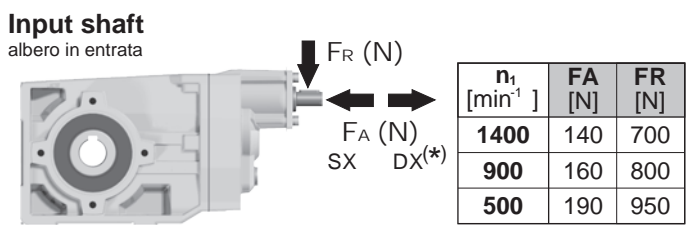

***Strong axial loads in the DX direction are not allowed.**
Non sono consentiti forti carichi assiali con direzione DX

PX43AC... Basic Gearbox
Riduttore base

Gearbox weight **7.93 kg**
peso riduttore

M. flanges	Kit code	øF	A
63B5	K050.4.041	138	205
71B5	K050.4.042	160	202.5
56B14	KC40.4.049	80	202.5
63B14	K050.4.047	90	205
71B14	K050.4.045	105	202.5

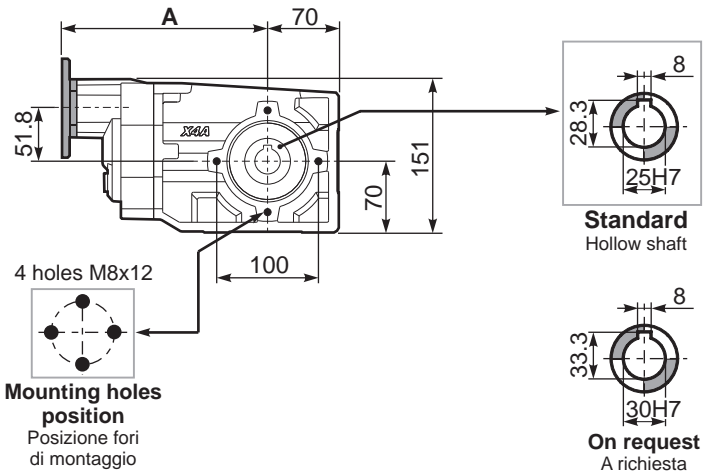
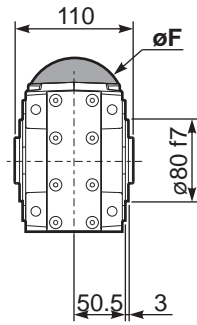

PX43A...FB.. Feet
Piedini

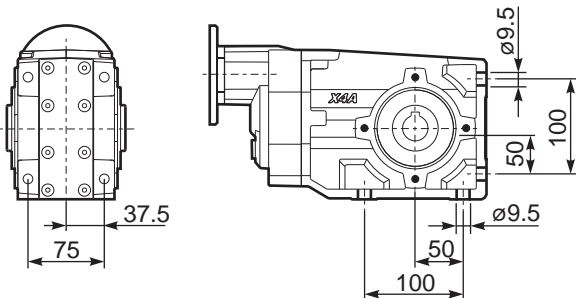

PX43A...-F2.. Output flange
Flangia uscita

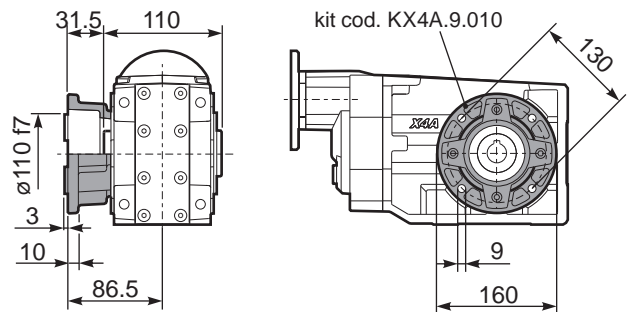

PX43A...-F3.. Output flange
Flangia uscita

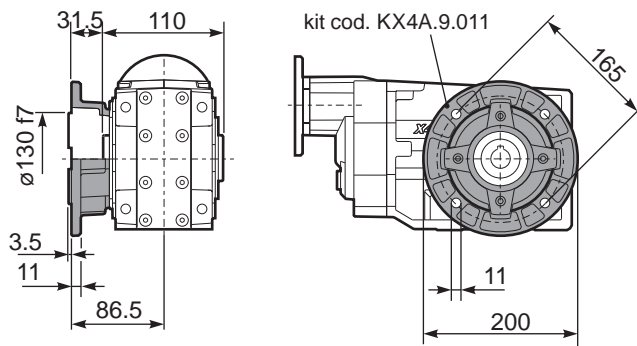

PX43A...BR.. Reaction Arm
Braccio di reazione

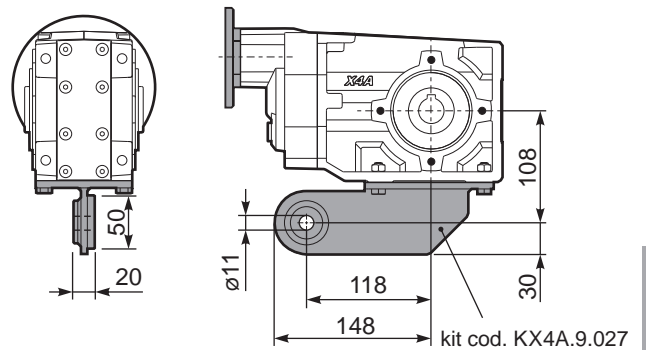

RX43A... Input shaft
Albero in entrata

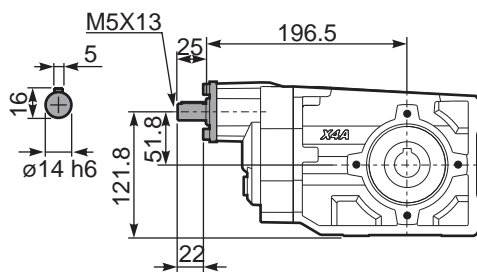

PX43A... Single output shaft
Albero semplice in uscita

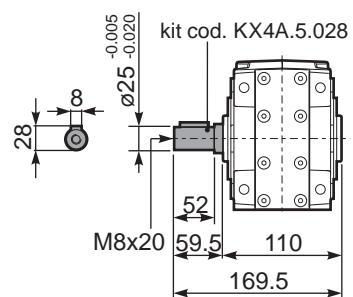

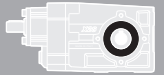

QUICK SELECTION / Selezione veloce The dynamic efficiency is **0.96** for all ratios **input speed (n₁) = 1400 min⁻¹**

Output Speed n ₂ [min ⁻¹]	Ratio i	Motor power P _{1M} [kW]	Output torque M _{2M} [Nm]	Service factor f.s.	Nominal power P _{1R} [kW]	Nominal torque M _{2R} [Nm]	Available B5 motor flanges				Available B14 motor flanges			Output Shaft 	Ratios code
							-C	-D	-E	-F	-R	-T	-U		
							71	80	90	100 112	80	90	100 112		
232	6.03	3	116	1.2	3.4	135	B							3011	01
151	9.26	3	179	0.9	2.6	155	B							308	02
123	11.36	3	219	1.0	3.1	230	B							2011	03
91	15.36	2.2	218	1.1	2.5	250	B							1611	04
80	17.46	2.2	248	1.0	2.2	250	B							208	05
70	19.97	2.2	284	0.9	1.9	250	B							1311	06
59	23.60	1.5	231	1.1	1.6	250	B							168	07
57	24.45	1.5	239	1.0	1.6	250	B							1111	08
45.6	30.69	1.1	220	1.1	1.2	250	B							138	09
39.6	35.35	1.1	253	1.0	1.1	250	B							811	10
37.3	37.57	1.1	269	0.9	1.0	250	B							118	11
28.8	48.68	0.75	239	1.0	0.78	250	B							611	12
25.8	54.33	0.75	267	0.9	0.70	250	B							88	13
18.7	74.81	0.37	181	1.2	0.43	210	B							68	14

A) Motor Flanges Available
Flange Motore Disponibili

B) Supplied with Reduction Bushing
Fornito con Bussola di Riduzione

B) Available on Request without reduction bushing
Disponibile a Richiesta senza Bussola di Riduzione

C) Motor Flange Holes Position
Posizione Fori Flangia Motore

EN Unit **X52A** is supplied with synthetic oil for lifetime lubrication, no maintenance is necessary. See table 1 for lubrication and recommended quantity. In table 2 please see possible radial loads and axial loads on the gearbox.

I Il riduttore **X52A** viene fornito completo di olio sintetico per la lubrificazione permanente e non necessita di alcuna manutenzione. Vedi tab.1 per oli e quantità consigliati. In tab.2 sono presenti i carichi radiali e assiali applicabili al riduttore.

D Das Getriebe **X52A** ist mit synthetischem Öl gefüllt und ist lebensdauergeschmiert. In Tabelle 1 ist die Schmiermenge und das empfohlene Schmiermittel angegeben. In Tabelle 2 sind die zulässigen Radial - und Axialbelastungen des Getriebes aufgeführt.

F Le réducteur **X52A** est fourni complet avec de l'huile synthétique pour la lubrification permanente et ne nécessite aucun entretien. Voir tableau 1 concernant les huiles et les quantités conseillées. Les charges radiales et axiales applicables au réducteur sont précisées dans le tableau 2.

E El reductor tamaño **X52A** se suministra, lubricado de por vida con aceite sintético y no requieren mantenimiento alguna. Ver tabla 1, para cantidades y aceites recomendados. En la tabla 2, se encuentran las cargas radiales y axiales admitidas por el reductor.

Standard supplied	For these mounting position specify in the order or add oil Per queste posizioni specificare in fase d'ordine o aggiungere olio							
B3	B6	B7	B8	V5	V6	V8	V8	V8
0.90 LT	1.50LT	0.75 LT	1.40 LT	1.95 LT	1.15 LT	1.15 LT	1.15 LT	Ask
SHELL Omala S4 WE 320				ENI Telium VSF 320				

For all details on lubrication and plugs check our website **tab. 1**
Per maggiori dettagli su lubrificazione e tappi olio vedi il nostro sito web

RADIAL AND AXIAL LOADS

Output shaft
Albero di uscita

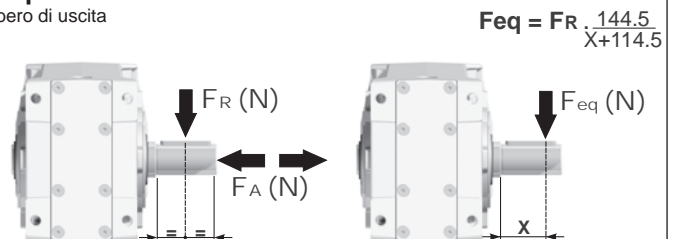

n ₂ [min ⁻¹]	FA	FR	n ₂ [min ⁻¹]	FA	FR	n ₂ [min ⁻¹]	FA	FR
250	600	3000	75	820	4100	15	1660	8300
150	700	3500	50	960	4800			
100	800	4000	25	1350	6750			

F_R On request taper roller bearings to increase radial loads.
A richiesta cuscinetti a rulli conici per aumentare i carichi radiali.

Input shaft
albero in entrata

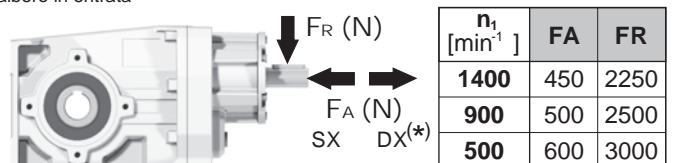

n ₁ [min ⁻¹]	FA	FR
1400	450	2250
900	500	2500
500	600	3000

*Strong axial loads in the DX direction are not allowed.
Non sono consentiti forti carichi assiali con direzione DX

tab. 2

PX52AC... Basic Gearbox
Riduttore base

Gearbox weight **12.80 kg**
peso riduttore

M. flanges	Kit code	øF	A
71B5	K023.4.041	160	234
80/90B5	K023.4.042	200	236
100/112B5	K023.4.043	250	245
80B14	K085.4.046	120	236
90B14	K085.4.045	140	236
100/112B14	K085.4.047	160	245

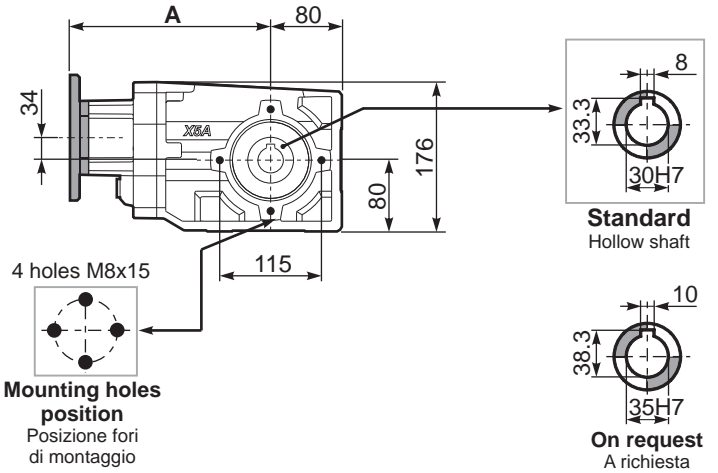
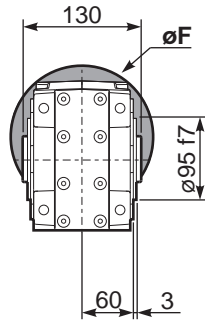

Mounting holes position
Posizione fori di montaggio

On request
A richiesta

PX52A...FB.. Feet
Piedini

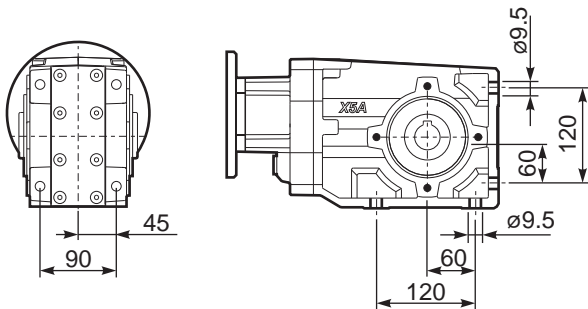

PX52A...-F2.. Output flange
Flangia uscita

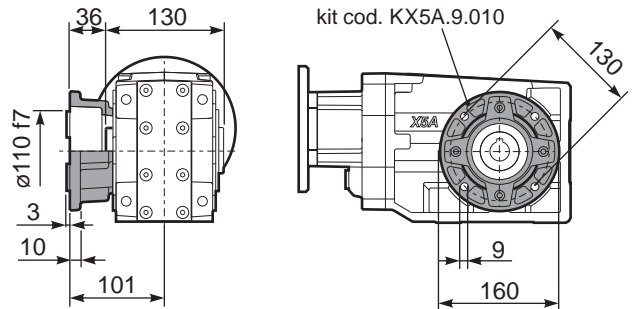

PX52A...-F3.. Output flange
Flangia uscita

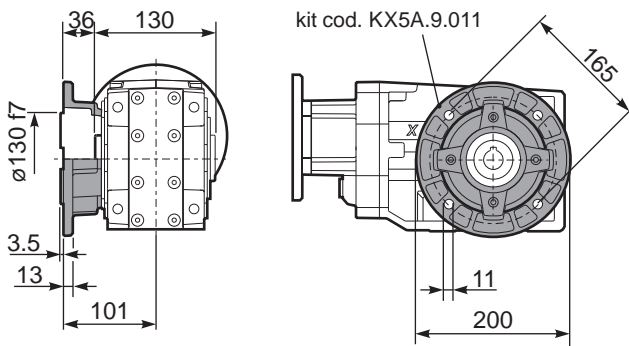

PX52A...-F4.. Output flange
Flangia uscita

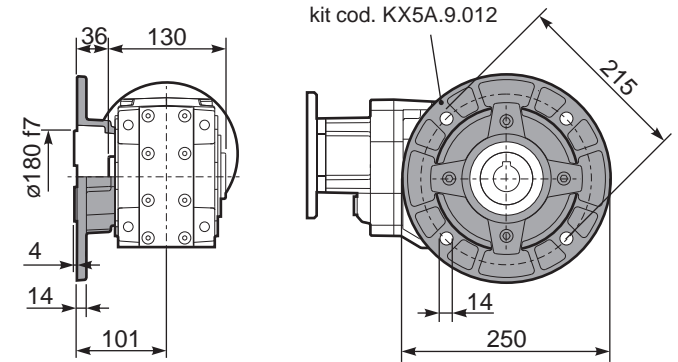

RX52A... Input shaft
Albero in entrata

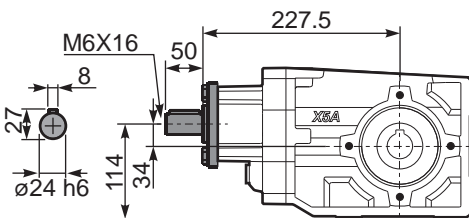

PX52A...BR.. Reaction Arm
Braccio di reazione

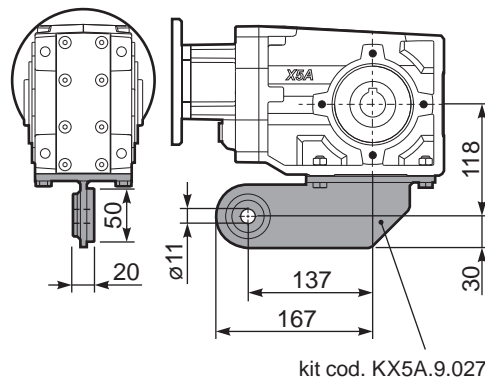

PX52AA... Single output shaft
Albero semplice in uscita

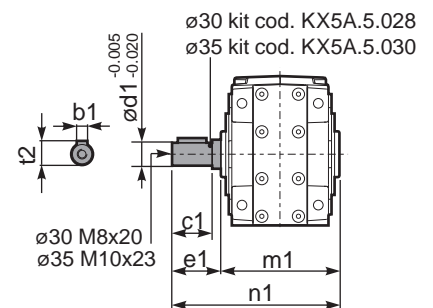

	b1	c1	d1	e1	m1	n1	t2
ø30	8	60	30	68	134	202	33
ø35	10	60	35	73.5	141	214.5	38

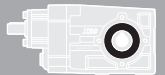

QUICK SELECTION / Selezione veloce The dynamic efficiency is **0.94** for all ratios **input speed (n₁) = 1400 min⁻¹**

Output Speed n ₂ [min ⁻¹]	Ratio i	Motor power P _{1M} [kW]	Output torque M _{2M} [Nm]	Service factor f.s.	Nominal power P _{1R} [kW]	Nominal torque M _{2R} [Nm]	Available B5 motor flanges				Available B14 motor flanges			Output Shaft 	Ratios code
							-B	-C	-D	-E	-Q	-R	-T		
							63	71	80	90	71	80	90		
24.7	56.76	0.55	201	1.2	0.69	250	B				C	C		191311	01
21.3	65.79	0.55	233	1.1	0.59	250	B				C	C		171311	02
18.1	77.23	0.55	274	0.9	0.50	250	B				C	C		151311	03
16.0	87.23	0.37	207	1.2	0.45	250	B				C	C		19138	04
15.2	92.18	0.37	219	1.1	0.42	250	B				C	C		131311	05
13.9	100.47	0.37	238	1.0	0.39	250	B				C	C		19811	06
12.0	116.45	0.37	276	0.9	0.33	250	B				C	C		17811	07
11.1	125.82	0.25	201	1.2	0.31	250	B				C	C	standard ø30	101311	08
9.9	141.66	0.25	227	1.1	0.28	250	B				C	C		13138	09
8.6	163.16	0.25	261	1.0	0.24	250	B				C	C		13811	10
7.8	178.96	0.18	219	1.1	0.22	250	B				C	C	ø35	1788	11
7.2	193.36	0.18	237	1.1	0.20	250	B				C	C	On request	10138	12
6.5	216.84	0.18	265	0.9	0.18	250	B				C	C		71311	13
5.5	252.36	0.12	200	1.3	0.15	250	B				C	C		9138	14
4.8	290.67	0.12	230	1.1	0.13	250	B				C	C		9811	15
4.2	333.23	0.12	263	0.9	0.12	250	B				C	C		7138	16
3.6	383.82	0.12	303	0.8	0.10	250	B				C	C		7811	17
3.1	446.70	0.12*	353	0.7	0.09	250	B				C	C		988	18
2.4	589.85	0.12*	466	0.5	0.07	250	B				C	C		788	19

Motor Flanges Available Flange Motore Disponibili
 B Supplied with Reduction Bushing Fornito con Bussola di Riduzione
 B Available on Request without reduction bushing Disponibile a Richiesta senza Bussola di Riduzione
 C Motor Flange Holes Position Posizione Fori Flangia Motore

* Power higher than the maximum one which can be supported by the gearbox. Select according to the torque M_{2R}
 Potenza superiore a quella massima sopportabile dal riduttore. Selezionare in base al momento torcente M_{2R}

EN Unit **X53A** is supplied with synthetic oil for lifetime lubrication, no maintenance is necessary. See table 1 for lubrication and recommended quantity. In table 2 please see possible radial loads and axial loads on the gearbox.

I Il riduttore **X53A** viene fornito completo di olio sintetico per la lubrificazione permanente e non necessita di alcuna manutenzione. Vedi tab.1 per oli e quantità consigliati. In tab.2 sono presenti i carichi radiali e assiali applicabili al riduttore.

D Das Getriebe **X53A** ist mit synthetischem Öl gefüllt und ist lebensdauergeschmiert. In Tabelle 1 ist die Schmiermenge und das empfohlene Schmiermittel angegeben. In Tabelle 2 sind die zulässigen Radial - und Axialbelastungen des Getriebes aufgeführt.

F Le réducteur **X53A** est fourni complet avec de l'huile synthétique pour la lubrification permanente et ne nécessite aucun entretien. Voir tableau 1 concernant les huiles et les quantités conseillées. Les charges radiales et axiales applicables au réducteur sont précisées dans le tableau 2.

E El reductor tamaño **X53A** se suministra, lubricado de por vida con aceite sintético y no requieren mantenimiento alguna. Ver tabla 1, para cantidades y aceites recomendados. En la tabla 2, se encuentran las cargas radiales y axiales admitidas por el reductor.

Standard supplied	For these mounting position specify in the order or add oil Per queste posizioni specificare in fase d'ordine o aggiungere olio					
B3	B6	B7	B8	V5	V6	V8
1.30 LT	1.55 LT	0.85 LT	1.45 LT	2.10 LT	1.25 LT	Ask
SHELL Omala S4 WE 320				ENI Telium VSF 320		

For all details on lubrication and plugs check our website **tab. 1**
 Per maggiori dettagli su lubrificazione e tappi olio vedi il nostro sito web

RADIAL AND AXIAL LOADS

Output shaft
 Albero di uscita

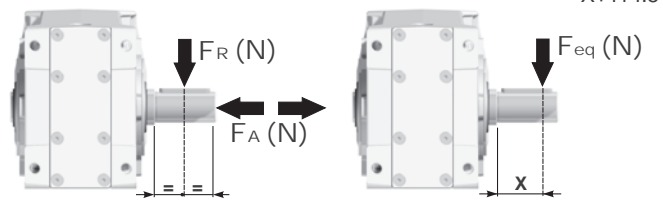

n ₂ [min ⁻¹]	FA	FR	n ₂ [min ⁻¹]	FA	FR	n ₂ [min ⁻¹]	FA	FR
250	600	3000	75	820	4100	15	1660	8300
150	700	3500	50	960	4800			
100	800	4000	25	1350	6750			

F_R On request taper roller bearings to increase radial loads.
 A richiesta cuscinetti a rulli conici per aumentare i carichi radiali.

Input shaft
 albero in entrata

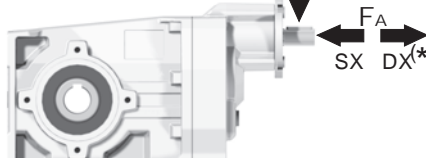

n ₁ [min ⁻¹]	FA [N]	FR [N]
1400	400	2000
900	440	2200
500	440	2200

*Strong axial loads in the DX direction are not allowed.
 Non sono consentiti forti carichi assiali con direzione DX

tab. 2

PX53AC... Basic Gearbox
Riduttore base

Gearbox weight
peso riduttore **12.65 kg**

M. flanges	Kit code	øF	A
63B5	K063.4.041	140	246
71B5	K063.4.042	160	244
80/90B5	K063.4.043	200	246
71B14	K063.4.047	105	244
80B14	K063.4.046	120	246
90B14	K063.4.041	140	246

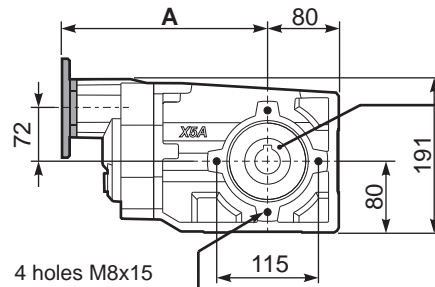
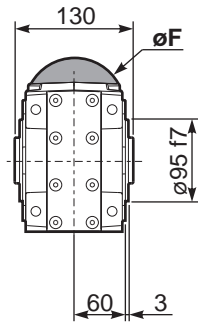

4 holes M8x15



Mounting holes position
Posizione fori di montaggio

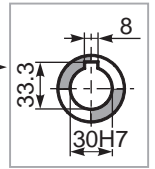

Standard
Hollow shaft

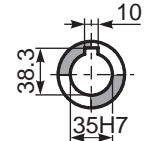

On request
A richiesta

PX53A...FB.. Feet
Piedini

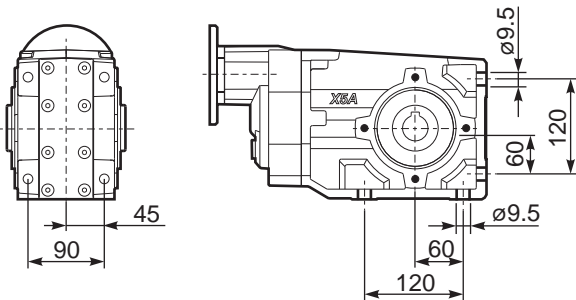

PX53A...-F2.. Output flange
Flangia uscita

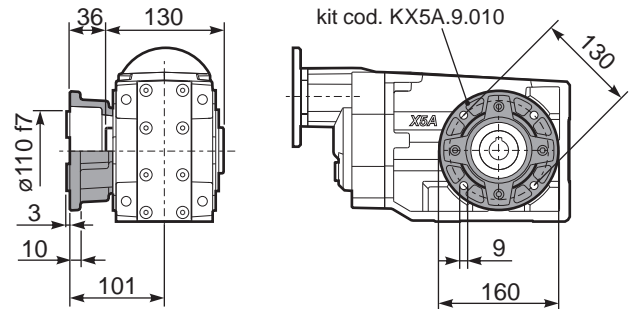

PX53A...-F3.. Output flange
Flangia uscita

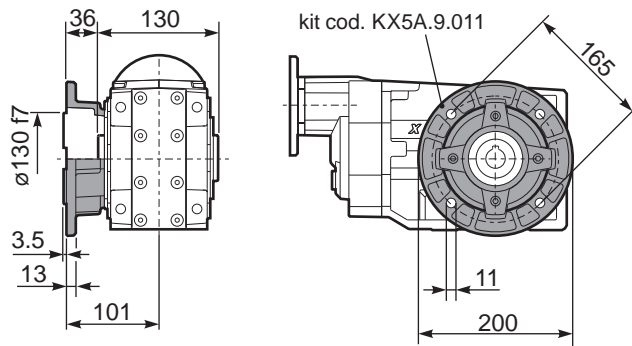

PX53A...-F4.. Output flange
Flangia uscita

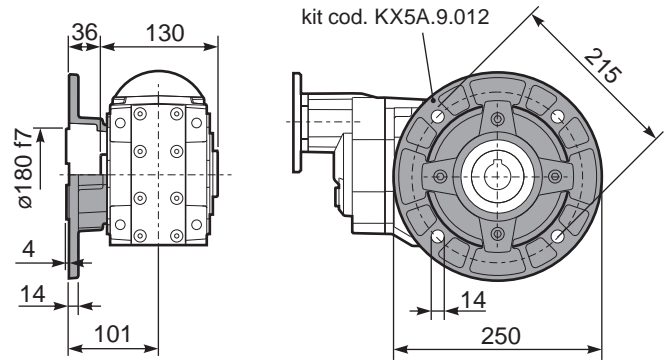

RX53A... Input shaft
Albero in entrata

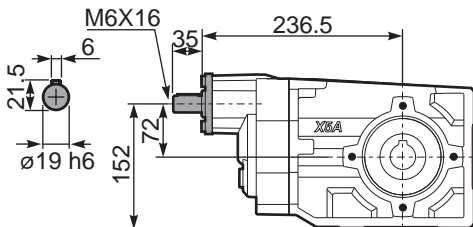

PX53A...BR.. Reaction Arm
Braccio di reazione

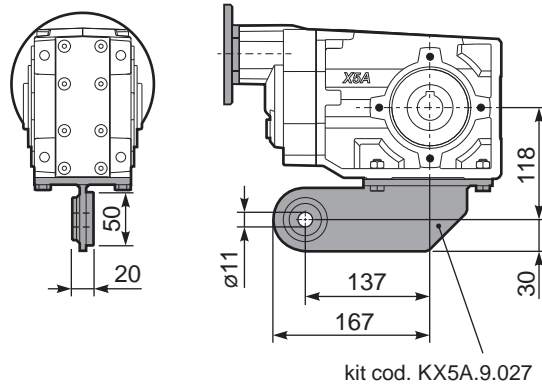

PX53AA... Single output shaft
Albero semplice in uscita

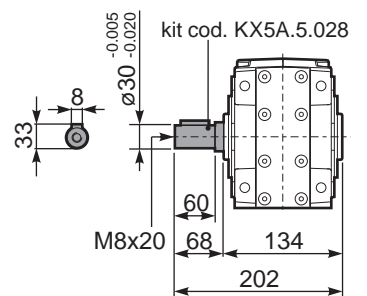

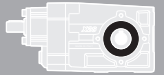

QUICK SELECTION / Selezione veloce The dynamic efficiency is **0.96** for all ratios **input speed (n₁) = 1400 min⁻¹**

Output Speed n ₂ [min ⁻¹]	Ratio i	Motor power P _{1M} [kW]	Output torque M _{2M} [Nm]	Service factor f.s.	Nominal power P _{1R} [kW]	Nominal torque M _{2R} [Nm]	Available B5 motor flanges					Available B14 motor flanges				Output Shaft 	Ratios code	
							-C	-D	-E	-F	-G	-R	-T	-U	-V			
							71	80	90	100 112	132	80	90	100 112	132			
232	6.03	5.5	211	1.1	6.1	240	B										3011	01
151	9.26	4	238	1.1	4.5	270	B										308	02
123	11.36	4	291	1.2	4.7	350	B										2011	03
91	15.36	4	394	1.0	3.8	385	B										1611	04
80	17.46	4	448	0.9	3.5	400	B										208	05
70	19.97	3	386	1.1	3.1	410	B										1311	06
59	23.60	3	456	0.9	2.7	410	B										168	07
57	24.45	3	472	0.9	2.6	410	B										1111	08
45.6	30.69	2.2	436	0.9	2.0	410	B										138	09
39.6	35.35	1.5	346	1.2	1.8	410	B										811	10
37.3	37.57	1.5	368	1.1	1.7	410	B										118	11
28.8	48.68	1.1	348	1.0	1.1	365	B										611	12
25.8	54.33	1.1	389	1.1	1.2	410	B										88	13
18.7	74.81	0.75	367	1.0	0.73	360	B										68	14

A) Motor Flanges Available
Flange Motore Disponibili

B) Supplied with Reduction Bushing
Fornito con Bussola di Riduzione

B) Available on Request without reduction bushing
Disponibile a Richiesta senza Bussola di Riduzione

C) Motor Flange Holes Position
Posizione Fori Flangia Motore

EN Unit **X62A** is supplied with synthetic oil for lifetime lubrication, no maintenance is necessary. See table 1 for lubrication and recommended quantity. In table 2 please see possible radial loads and axial loads on the gearbox.

I Il riduttore **X62A** viene fornito completo di olio sintetico per la lubrificazione permanente e non necessita di alcuna manutenzione. Vedi tab.1 per oli e quantità consigliati. In tab.2 sono presenti i carichi radiali e assiali applicabili al riduttore.

D Das Getriebe **X62A** ist mit synthetischem Öl gefüllt und ist lebensdauergeschmiert. In Tabelle 1 ist die Schmiermenge und das empfohlene Schmiermittel angegeben. In Tabelle 2 sind die zulässigen Radial - und Axialbelastungen des Getriebes aufgeführt.

F Le réducteur **X62A** est fourni complet avec de l'huile synthétique pour la lubrification permanente et ne nécessite aucun entretien. Voir tableau 1 concernant les huiles et les quantités conseillées. Les charges radiales et axiales applicables au réducteur sont précisées dans le tableau 2.

E El reductor tamaño **X62A** se suministra, lubricado de por vida con aceite sintético y no requieren mantenimiento alguna. Ver tabla 1, para cantidades y aceites recomendados. En la tabla 2, se encuentran las cargas radiales y axiales admitidas por el reductor.

Standard supplied	For these mounting position specify in the order or add oil Per queste posizioni specificare in fase d'ordine o aggiungere olio						
B3	B6	B7	B8	V5	V6	V8	
1.25 LT	1.70 LT	0.95 LT	1.60 LT	2.45 LT	1.50 LT	Ask	
SHELL Omala S4 WE 320				ENI Telium VSF 320			

For all details on lubrication and plugs check our website **tab. 1**
Per maggiori dettagli su lubrificazione e tappi olio vedi il nostro sito web

RADIAL AND AXIAL LOADS

Output shaft
Albero di uscita

$$F_{eq} = F_R \cdot \frac{168}{X+138}$$

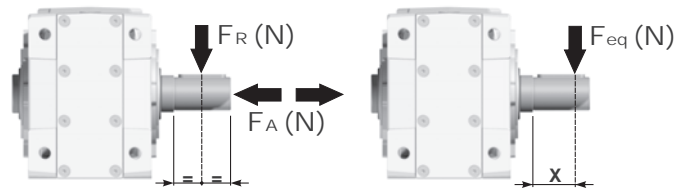

n ₂ [min ⁻¹]	FA	FR	n ₂ [min ⁻¹]	FA	FR	n ₂ [min ⁻¹]	FA	FR
250	600	3000	75	890	4450	15	1660	8300
150	700	3500	50	1140	5700			
100	780	3900	25	1330	6650			

F_R On request taper roller bearings to increase radial loads.
A richiesta cuscinetti a rulli conici per aumentare i carichi radiali.

Input shaft
albero in entrata

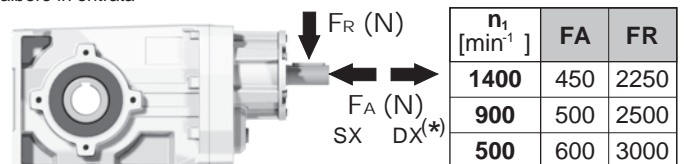

***Strong axial loads in the DX direction are not allowed.**
Non sono consentiti forti carichi assiali con direzione DX

tab. 2

PX62AC... Basic Gearbox
Riduttore base

Gearbox weight
peso riduttore **15.80 kg**

M. flanges	Kit code	øF	A
71B5	K023.4.041	160	253
80/90B5	K023.4.042	200	255
100/112B5	K023.4.043	250	264
132B5	KC51.4.043	300	285
80B14	K085.4.046	120	255
90B14	K085.4.045	140	255
100/112B14	K085.4.047	160	264
132B14	KC51.4.041	200	285

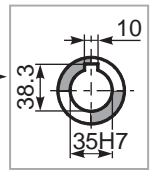
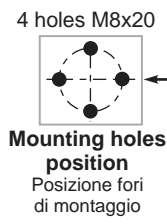
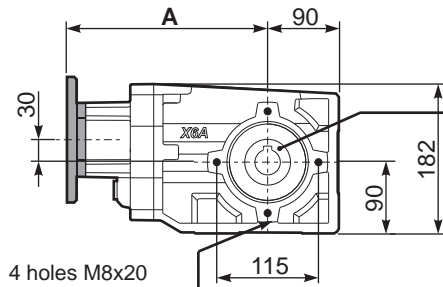
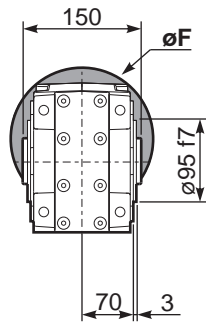

Standard
Hollow shaft

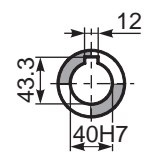

On request
A richiesta

PX62A...FB.. Feet
Piedini

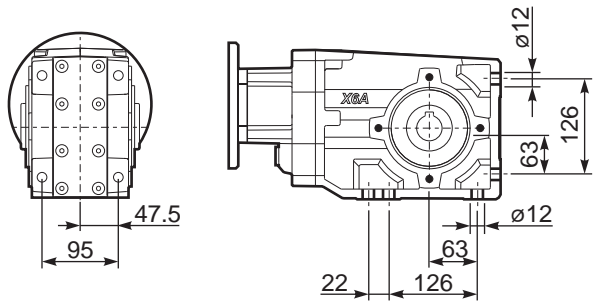

PX62A...-F2.. Output flange
Flangia uscita

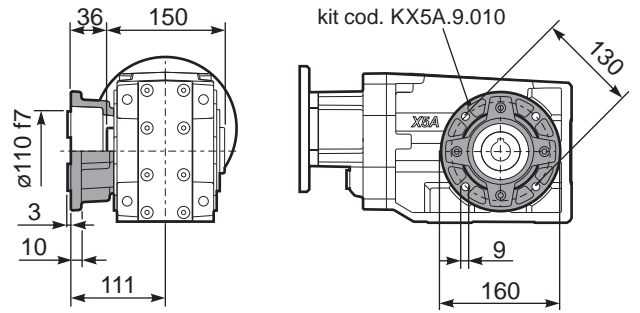

PX62A...-F3.. Output flange
Flangia uscita

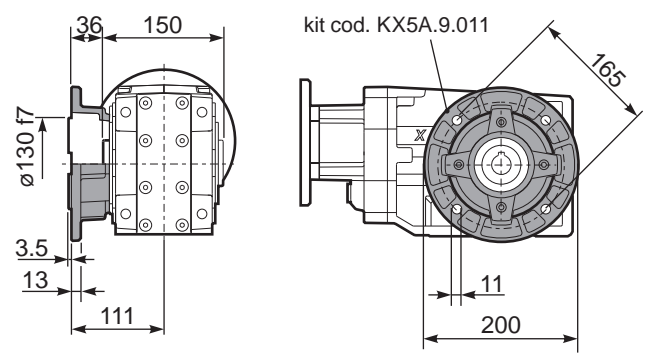

PX62A...-F4.. Output flange
Flangia uscita

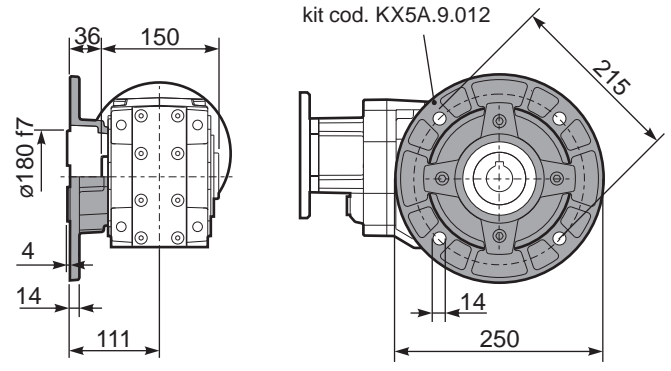

RX62A... Input shaft
Albero in entrata

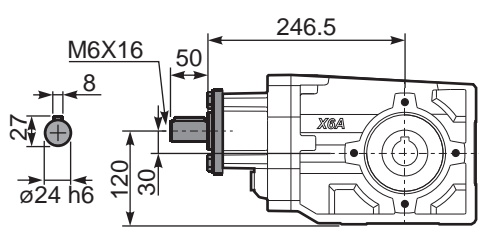

PX62A...BR.. Reaction Arm
Braccio di reazione

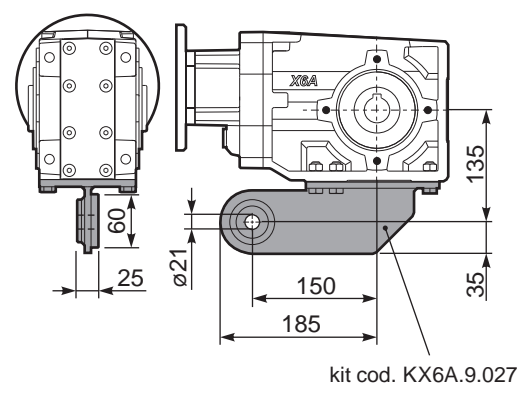

PX62AA... Single output shaft
Albero semplice in uscita

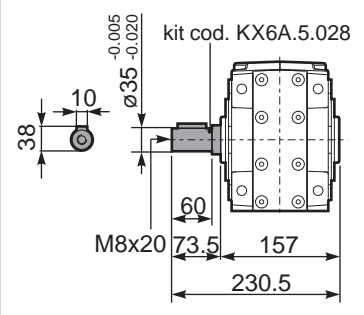

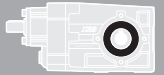

QUICK SELECTION / Selezione veloce The dynamic efficiency is **0.94** for all ratios **input speed (n₁) = 1400 min⁻¹**

Output Speed n ₂ [min ⁻¹]	Ratio i	Motor power P _{1M} [kW]	Output torque M _{2M} [Nm]	Service factor f.s.	Nominal power P _{1R} [kW]	Nominal torque M _{2R} [Nm]	Available B5 motor flanges				Available B14 motor flanges			Output Shaft 	Ratios code
							-B	-C	-D	-E	-Q	-R	-T		
							63	71	80	90	71	80	90		
24.7	56.76	1.1	398	1.0	1.1	410	B				C	C		191311	01
21.3	65.79	0.75	316	1.3	0.97	410	B				C	C		171311	02
18.1	77.23	0.75	371	1.1	0.83	410	B				C	C		151311	03
16.0	87.23	0.75	420	1.0	0.73	410	B				C	C		19138	04
15.2	92.18	0.75	443	0.9	0.69	410	B				C	C		131311	05
13.9	100.47	0.55	357	1.2	0.64	410	B				C	C		19811	06
12.0	116.45	0.55	413	1.0	0.55	410	B				C	C		17811	07
11.1	125.82	0.55	446	0.9	0.51	410	B				C	C		101311	08
9.9	141.66	0.37	336	1.2	0.45	410	B				C	C		13138	09
8.6	163.16	0.37	387	1.1	0.39	410	B				C	C		13811	10
7.8	178.96	0.37	424	1.0	0.36	410	B				C	C		1788	11
7.2	193.36	0.37	459	0.9	0.33	410	B				C	C		10138	12
6.5	216.84	0.25	347	1.2	0.29	410	B				C	C		71311	13
5.5	252.36	0.25	404	1.0	0.25	410	B				C	C		9138	14
4.8	290.67	0.25	465	0.9	0.22	410	B				C	C		9811	15
4.2	333.23	0.18	408	1.0	0.19	410	B				C	C		7138	16
3.6	383.82	0.18	470	0.9	0.17	410	B				C	C		7811	17
3.1	446.70	0.12	353	1.2	0.14	410	B				C	C		988	18
2.4	589.85	0.12	466	0.9	0.11	410	B				C	C		788	19

Motor Flanges Available Flange Motore Disponibili
 B Supplied with Reduction Bushing Fornito con Bussola di Riduzione
 B Available on Request without reduction bushing Disponibile a Richiesta senza Bussola di Riduzione
 C Motor Flange Holes Position Posizione Fori Flangia Motore

EN Unit **X63A** is supplied with synthetic oil for lifetime lubrication, no maintenance is necessary. See table 1 for lubrication and recommended quantity. In table 2 please see possible radial loads and axial loads on the gearbox.

I Il riduttore **X63A** viene fornito completo di olio sintetico per la lubrificazione permanente e non necessita di alcuna manutenzione. Vedi tab.1 per oli e quantità consigliati. In tab.2 sono presenti i carichi radiali e assiali applicabili al riduttore.

D Das Getriebe **X63A** ist mit synthetischem Öl gefüllt und ist lebensdauergeschmiert. In Tabelle 1 ist die Schmiermenge und das empfohlene Schmiermittel angegeben. In Tabelle 2 sind die zulässigen Radial - und Axialbelastungen des Getriebes aufgeführt.

F Le réducteur **X63A** est fourni complet avec de l'huile synthétique pour la lubrification permanente et ne nécessite aucun entretien. Voir tableau 1 concernant les huiles et les quantités conseillées. Les charges radiales et axiales applicables au réducteur sont précisées dans le tableau 2.

E El reductor tamaño **X63A** se suministra, lubricado de por vida con aceite sintético y no requieren mantenimiento alguna. Ver tabla 1, para cantidades y aceites recomendados. En la tabla 2, se encuentran las cargas radiales y axiales admitidas por el reductor.

Standard supplied	For these mounting position specify in the order or add oil Per queste posizioni specificare in fase d'ordine o aggiungere olio						
1.80 LT	1.80 LT	1.05 LT	1.70 LT	2.60 LT	1.65 LT	Ask	
SHELL Omala S4 WE 320				ENI Telium VSF 320			

For all details on lubrication and plugs check our website **tab. 1**
Per maggiori dettagli su lubrificazione e tappi olio vedi il nostro sito web

RADIAL AND AXIAL LOADS

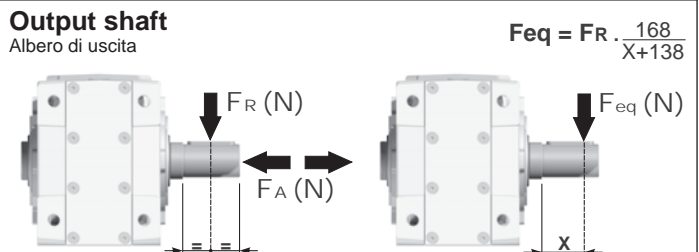

n ₂ [min ⁻¹]	FA	FR	n ₂ [min ⁻¹]	FA	FR	n ₂ [min ⁻¹]	FA	FR
250	600	3000	75	890	4450	15	1660	8300
150	700	3500	50	1140	5700			
100	780	3900	25	1330	6650			

F_R On request taper roller bearings to increase radial loads.
A richiesta cuscinetti a rulli conici per aumentare i carichi radiali.

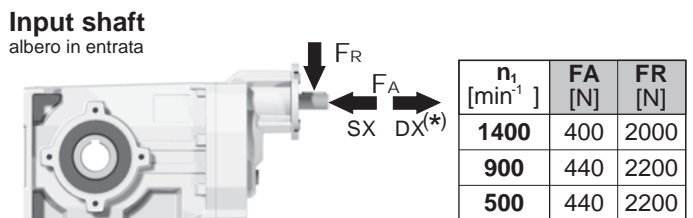

***Strong axial loads in the DX direction are not allowed.**
Non sono consentiti forti carichi assiali con direzione DX

tab. 2

PX63AC... Basic Gearbox
Riduttore base

Gearbox weight **15.98 kg**
peso riduttore

M. flanges	Kit code	øF	A
63B5	K063.4.041	140	265
71B5	K063.4.042	160	263
80/90B5	K063.4.043	200	265
71B14	K063.4.047	105	263
80B14	K063.4.046	120	265
90B14	K063.4.041	140	265

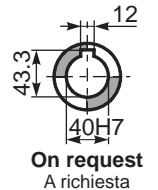
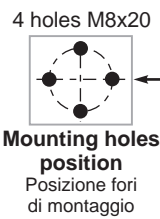
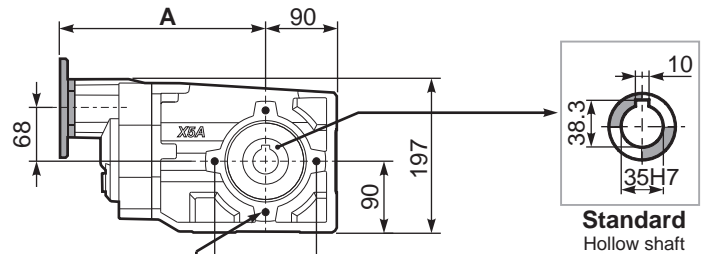
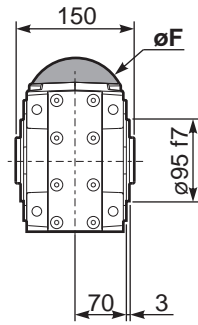

PX63A...FB.. Feet
Piedini

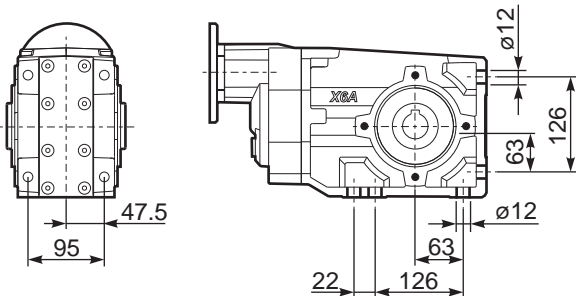

PX63A...-F2.. Output flange
Flangia uscita

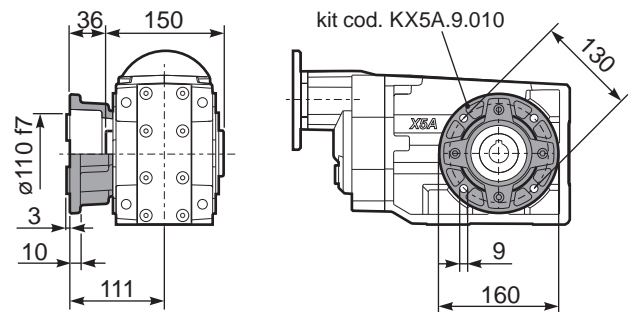

PX63A...-F3.. Output flange
Flangia uscita

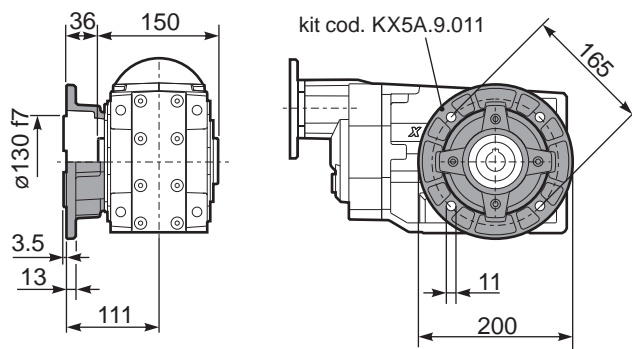

PX63A...-F4.. Output flange
Flangia uscita

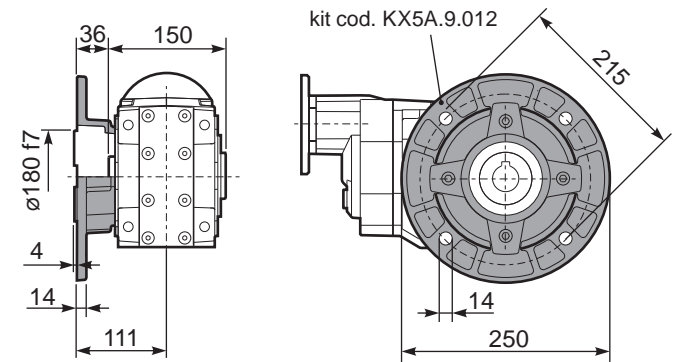

RX63A... Input shaft
Albero in entrata

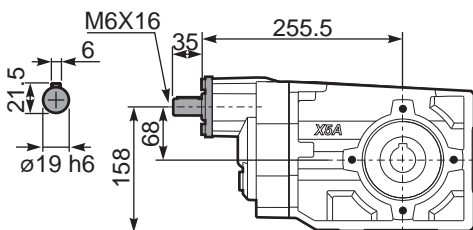

PX63A...BR.. Reaction Arm
Braccio di reazione

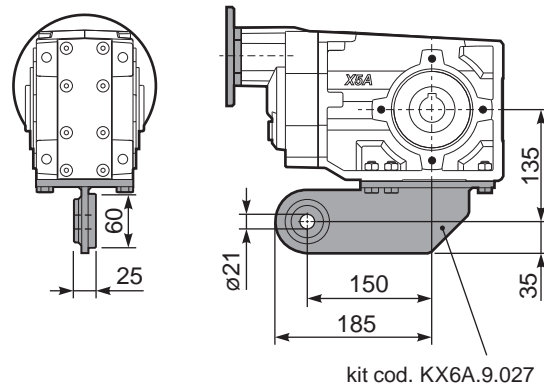

PX63AA... Single output shaft
Albero semplice in uscita

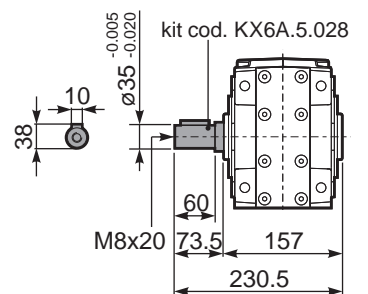



QUICK SELECTION / Selezione veloce

input speed (n₁) = 1400 min⁻¹

Output Speed n ₂ [min ⁻¹]	Ratio i	Motor power P _{1M} [kW]	Output torque M _{2M} [Nm]	Service factor f.s.	Nominal power P _{1R} [kW]	Nominal torque M _{2R} [Nm]	Available B5 motor flanges					Available B14 motor flanges				Output Shaft 	Ratios code	
							-C	-D	-E	-F	-G	-R	-T	-U	-V			
							71	80	90	100 112	132	80	90	100 112	132			
176	7.94	7.5	369	1.0	7.5	380	B										302418	01
153	9.13	7.5	425	0.9	6.7	390	B										302416	02
131	10.66	5.5	366	1.1	6.0	410	B										302414	03
94	14.97	5.5	514	1.1	6.0	580	B										202418	04
81	17.21	5.5	591	1.0	5.4	600	B										202416	05
69	20.24	5.5	695	1.0	5.2	675	B										162418	06
60	23.27	4	585	1.2	4.5	675	B										162416	07
53	26.31	4	661	1.0	4.0	675	B										132418	08
46.3	30.25	4	760	0.9	3.5	675	B										132416	09
39.6	35.32	3	668	1.0	3.0	675	B										132414	10
37.8	37.03	3	701	1.0	2.8	675	B										112416	11
32.4	43.23	2.2	602	1.1	2.4	675	B										112414	12
30.1	46.58	2.2	649	1.0	2.3	675	B										82418	13
26.1	53.55	2.2	746	0.9	2.0	675	B										82416	14
22.4	62.52	1.5	600	1.1	1.7	675	B										82414	15
19.0	73.75	1.1	517	1.1	1.2	580	B										62416	16
16.3	86.09	1.1	604	1.1	1.2	675	B										62414	17

The dynamic efficiency is **0.94** for all ratios

A Motor Flanges Available
Flange Motore Disponibili

B Supplied with Reduction Bushing
Fornito con Bussola di Riduzione

B Available on Request without reduction bushing
Disponibile a Richiesta senza Bussola di Riduzione

C Motor Flange Holes Position
Posizione Fori Flangia Motore

EN Unit **X73C** is supplied with synthetic oil for lifetime lubrication, no maintenance is necessary. See table 1 for lubrication and recommended quantity. In table 2 please see possible radial loads and axial loads on the gearbox.

I Il riduttore **X73C** viene fornito completo di olio sintetico per la lubrificazione permanente e non necessita di alcuna manutenzione. Vedi tab.1 per oli e quantità consigliati. In tab.2 sono presenti i carichi radiali e assiali applicabili al riduttore.

D Das Getriebe **X73C** ist mit synthetischem Öl gefüllt und ist lebensdauergeschmiert. In Tabelle 1 ist die Schmiermenge und das empfohlene Schmiermittel angegeben. In Tabelle 2 sind die zulässigen Radial - und Axialbelastungen des Getriebes aufgeführt.

F Le réducteur **X73C** est fourni complet avec de l'huile synthétique pour la lubrification permanente et ne nécessite aucun entretien. Voir tableau 1 concernant les huiles et les quantités conseillées. Les charges radiales et axiales applicables au réducteur sont précisées dans le tableau 2.

E El reductor tamaño **X73C** se suministra, lubricado de por vida con aceite sintético y no requieren mantenimiento alguna. Ver tabla 1, para cantidades y aceites recomendados. En la tabla 2, se encuentran las cargas radiales y axiales admitidas por el reductor.

Standard supplied	For these mounting position specify in the order or add oil Per queste posizioni specificare in fase d'ordine o aggiungere olio					
B3	B6	B7	B8	V5	V6	V8
2.45 LT	2.55 LT	1.80 LT	1.95 LT	4.05 LT	2.55 LT	Ask
SHELL Omala S4 WE 320				ENI Telium VSF 320		

For all details on lubrication and plugs check our website **tab. 1**
Per maggiori dettagli su lubrificazione e tappi olio vedi il nostro sito web

RADIAL AND AXIAL LOADS

Output shaft
Albero di uscita

$$F_{eq} = F_R \cdot \frac{178.5}{X+143.5}$$

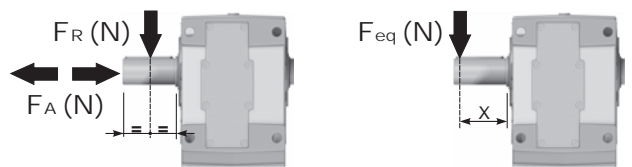

n ₂	FA	FR	n ₂	FA	FR	n ₂	FA	FR
300	1360	6800	140	1480	7400	70	1720	8600
250	1400	7000	120	1520	7600	40	1840	9200
200	1440	7200	85	1560	7800	15	1920	9600

On request reinforced bearings to increase loads.

A richiesta cuscinetti rinforzati per aumentare i carichi.

Input shaft

Albero in entrata

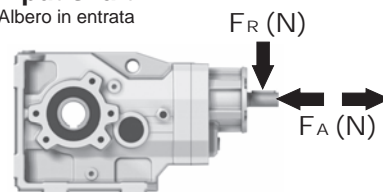

n ₁	FA	FR
1400	400	2000
900	440	2200
500	440	2200

tab. 2

PX73CC... Basic Gearbox
Riduttore base

Gearbox weight
peso riduttore **41.0 kg**

M. flanges	Kit code	øF	A
71B5	K023.4.041	160	298.9
80/90B5	K023.4.042	200	300.9
100/112B5	K023.4.043	250	309.9
132B5	KC51.4.043	300	330.9
80B14	K085.4.046	120	300.9
90B14	K085.4.045	140	300.9
100/112B14	K085.4.047	160	309.9
132B14	KC51.4.041	200	330.9

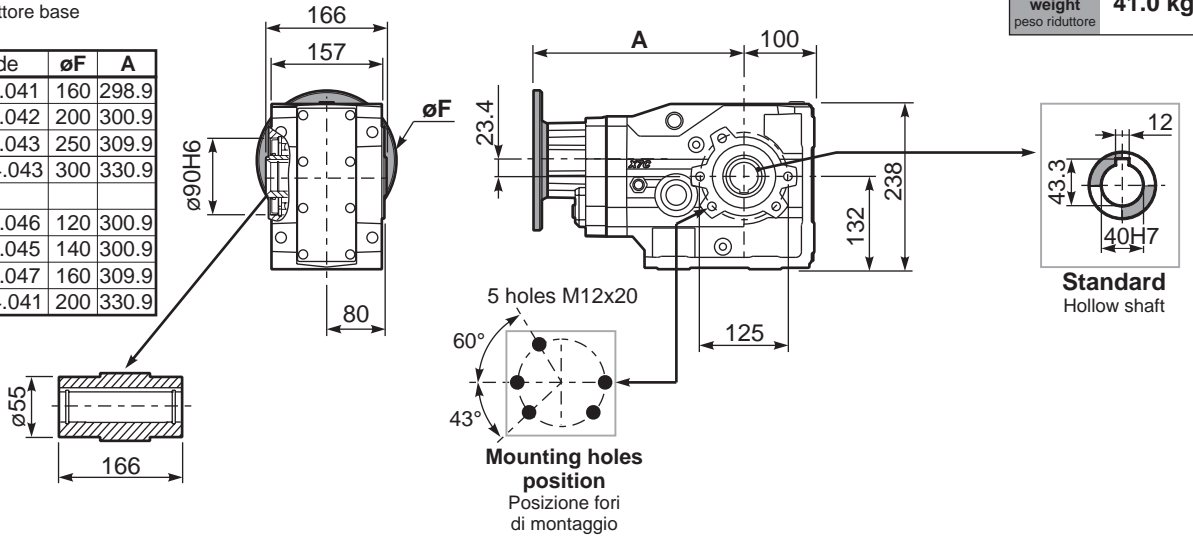

PX73C...FB.. Feet
Piedini

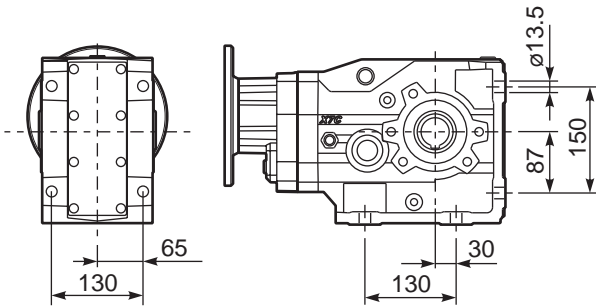

PX73C...-F4.. Output flange
Flangia uscita

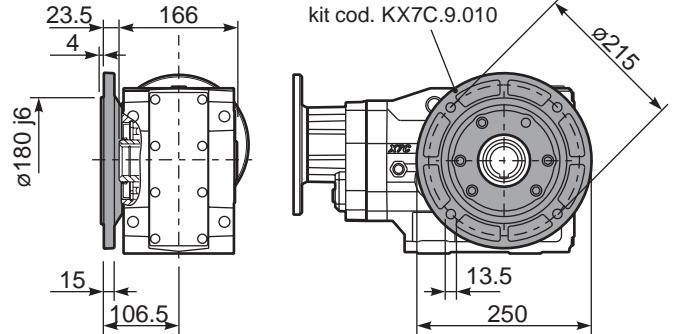

PX73C...BR.. Reaction Arm
Braccio di reazione

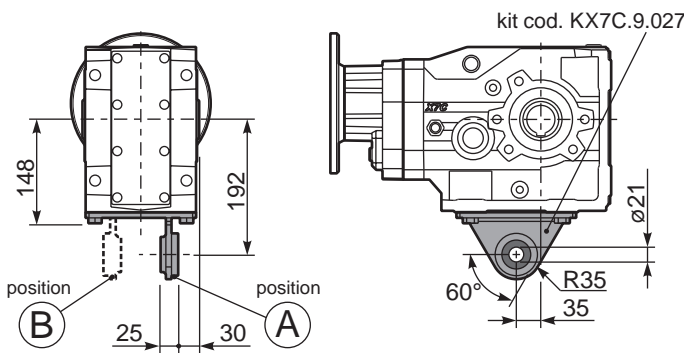

RX73C... Input shaft
Albero in entrata

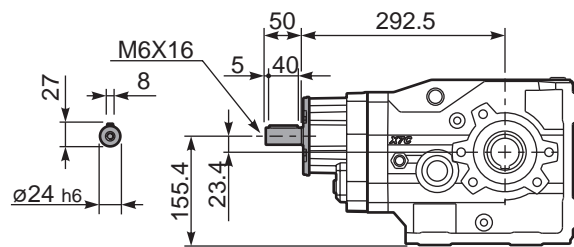

PX73CA... Single shaft
Albero lento semplice

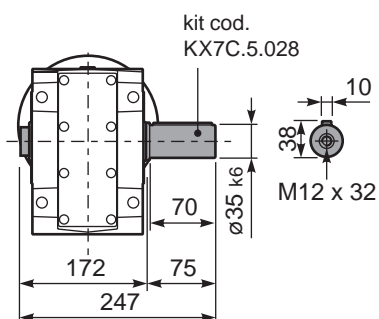

PX73CB... Double shaft
Albero lento bisp.

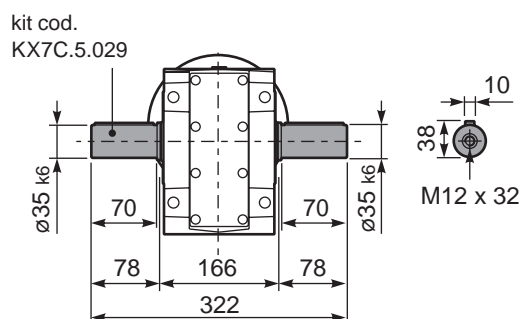

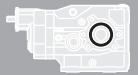

QUICK SELECTION / Selezione veloce

input speed (n₁) = 1400 min⁻¹

Output Speed n ₂ [min ⁻¹]	Ratio i	Motor power P _{1M} [kW]	Output torque M _{2M} [Nm]	Service factor f.s.	Nominal power P _{1R} [kW]	Nominal torque M _{2R} [Nm]	Available B5 motor flanges				Available B14 motor flanges			Output Shaft \varnothing	Ratios code
							-B	-C	-D	-E	-Q	-R	-T		
							63	71	80	90	71	80	90		
18.7	74.79	1.5	704	1.0	1.4	675	B				C	C		19132418	01
16.3	85.99	1.1	591	1.1	1.3	675	B				C	C		19132416	02
14.0	99.66	1.1	685	1.0	1.1	675	B				C	C		17132416	03
12.0	116.35	0.75	548	1.2	0.92	675	B				C	C		17132414	04
11.5	121.45	0.75	572	1.2	0.89	675	B				C	C		13132418	05
10.0	139.64	0.75	658	1.0	0.77	675	B				C	C		13132416	06
9.2	152.21	0.75	717	0.9	0.71	675	B				C	C		19082416	07
8.6	163.02	0.55	567	1.2	0.66	675	B				C	C		13132414	08
7.9	177.69	0.55	618	1.1	0.61	675	B				C	C		19082414	09
6.8	205.95	0.55	716	0.9	0.52	675	B				C	C		17082414	10
6.3	222.52	0.55	774	0.9	0.48	675	B				C	C		10132414	11
5.6	248.76	0.37	578	1.2	0.43	675	B				C	C		9132416	12
4.8	290.41	0.37	675	1.0	0.37	675	B				C	C		9132414	13
4.1	337.39	0.37	784	0.9	0.32	675	B				C	C		10082416	14
3.6	393.88	0.25	618	1.1	0.27	675	B				C	C		10082414	15
3.2	440.33	0.25	690	1.0	0.24	675	B				C	C		9082416	16
2.7	514.06	0.18	616	1.1	0.21	675	B				C	C		9082414	17
2.4	581.44	0.18	697	1.0	0.18	675	B				C	C		7082416	18
2.1	678.79	0.12	526	1.3	0.16	675	B				C	C		7082414	19

The dynamic efficiency is **0.92** for all ratios

A Motor Flanges Available
Flange Motore Disponibili

B Supplied with Reduction Bushing
Fornito con Bussola di Riduzione

B Available on Request without reduction bushing
Disponibile a Richiesta senza Bussola di Riduzione

C Motor Flange Holes Position
Posizione Fori Flangia Motore

EN Unit **X74C** is supplied with synthetic oil for lifetime lubrication, no maintenance is necessary. See table 1 for lubrication and recommended quantity. In table 2 please see possible radial loads and axial loads on the gearbox.

I Il riduttore **X74C** viene fornito completo di olio sintetico per la lubrificazione permanente e non necessita di alcuna manutenzione. Vedi tab.1 per oli e quantità consigliati. In tab.2 sono presenti i carichi radiali e assiali applicabili al riduttore.

D Das Getriebe **X74C** ist mit synthetischem Öl gefüllt und ist lebensdauergeschmiert. In Tabelle 1 ist die Schmiermenge und das empfohlene Schmiermittel angegeben. In Tabelle 2 sind die zulässigen Radial - und Axialbelastungen des Getriebes aufgeführt.

F Le réducteur **X74C** est fourni complet avec de l'huile synthétique pour la lubrification permanente et ne nécessite aucun entretien. Voir tableau 1 concernant les huiles et les quantités conseillées. Les charges radiales et axiales applicables au réducteur sont précisées dans le tableau 2.

E El reductor tamaño **X74C** se suministra, lubricado de por vida con aceite sintético y no requieren mantenimiento alguna. Ver tabla 1, para cantidades y aceites recomendados. En la tabla 2, se encuentran las cargas radiales y axiales admitidas por el reductor.

Standard supplied	For these mounting position specify in the order or add oil Per queste posizioni specificare in fase d'ordine o aggiungere olio					
3.55 LT	2.65 LT	1.90 LT	2.05 LT	4.25 LT	2.65 LT	Ask
SHELL Omala S4 WE 320				ENI Telium VSF 320		

For all details on lubrication and plugs check our website **tab. 1**
Per maggiori dettagli su lubrificazione e tappi olio vedi il nostro sito web

RADIAL AND AXIAL LOADS

Output shaft
Albero di uscita

$$F_{eq} = FR \cdot \frac{178.5}{X+143.5}$$

n ₂	FA	FR	n ₂	FA	FR	n ₂	FA	FR
300	1360	6800	140	1480	7400	70	1720	8600
250	1400	7000	120	1520	7600	40	1840	9200
200	1440	7200	85	1560	7800	15	1920	9600

On request reinforced bearings to increase loads.
A richiesta cuscinetti rinforzati per aumentare i carichi.

Input shaft
Albero in entrata

n ₁	FA	FR
1400	240	1200
900	280	1400
500	310	1700

tab. 2

PX74CC... Basic Gearbox
Riduttore base

Gearbox weight **39.0 kg**
peso riduttore

M. flanges	Kit code	øF	A
63B5	K063.4.041	140	310.9
71B5	K063.4.042	160	308.9
80/90B5	K063.4.043	200	310.9
71B14	K063.4.047	105	308.9
80B14	K063.4.046	120	310.9
90B14	K063.4.041	140	310.9

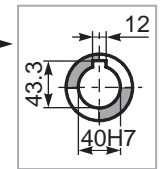
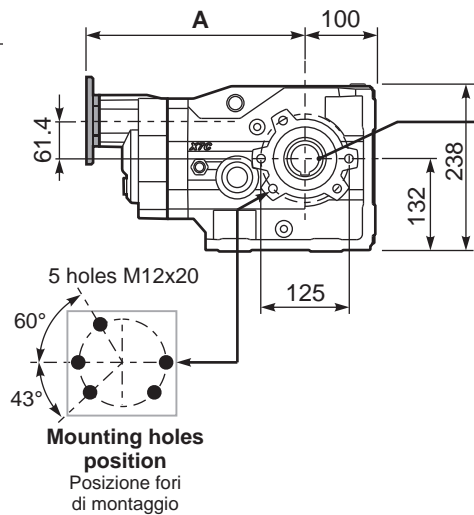
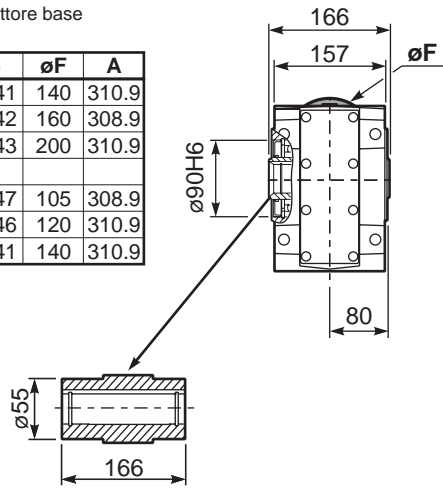

Standard Hollow shaft

PX74C...FB.. Feet
Piedini

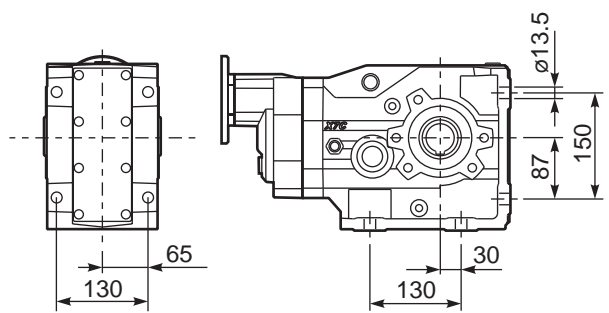

PX74C...-F4.. Output flange
Flangia uscita

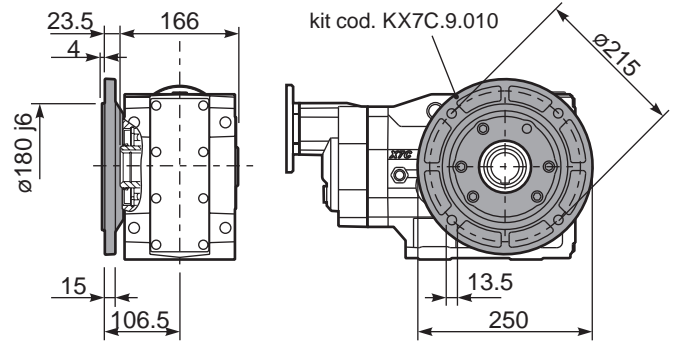

PX74C...BR.. Reaction Arm
Braccio di reazione

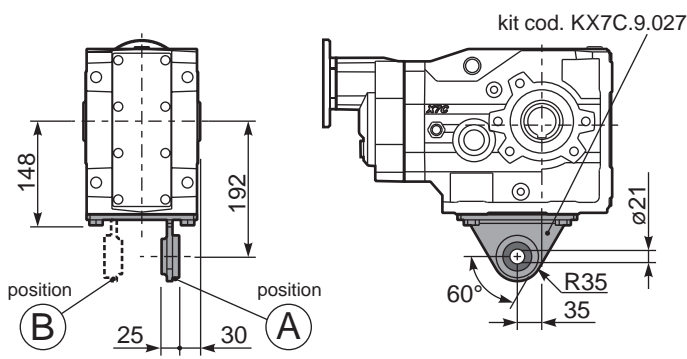

RX74C... Input shaft
Albero in entrata

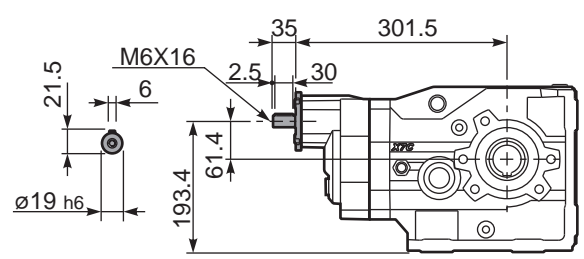

PX74CA... Single shaft
Albero lento semplice

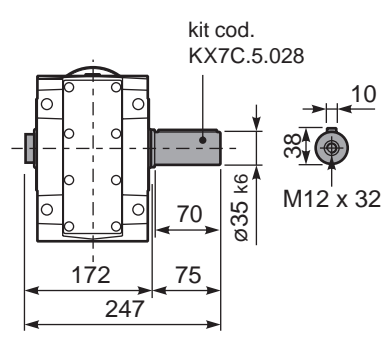

PX74CB... Double shaft
Albero lento bisp.

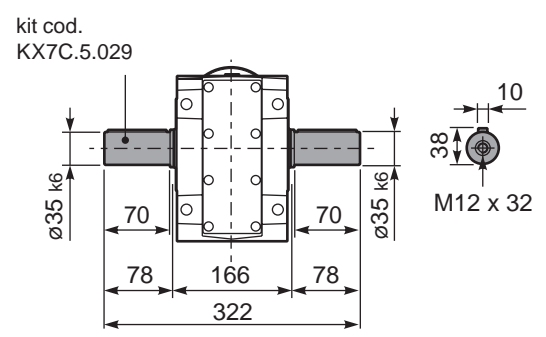

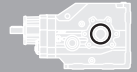

QUICK SELECTION / Selezione veloce input speed (n_1) = 1400 min⁻¹

Output Speed n_2 [min ⁻¹]	Ratio i	Motor power P_{1M} [kW]	Output torque M_{2M} [Nm]	Service factor $f.s.$	Nominal power P_{1R} [kW]	Nominal torque M_{2R} [Nm]	Available B5 motor flanges					Available B14 motor flanges				Output Shaft \varnothing	Ratios code
							-C	-D	-E	-F	-G	-R	-T	-U	-V		
							71	80	90	100 112	132	80	90	100 112	132		
145	9.69	9	560	1.3	12.2	755	B									302418	01
126	11.09	9	641	1.1	9.6	680	B									302416	02
108	12.90	9	746	1.1	9.6	790	B									302414	03
77	18.26	7.5	849	1.1	8.0	935	B									202418	04
67	20.91	7.5	972	1.0	7.5	1000	B									202416	05
58	24.32	5.5	835	1.2	6.4	1000	B									202414	06
49.5	28.27	5.5	971	1.0	5.5	1000	B									162416	07
42.6	32.88	4	826	1.2	4.7	1000	B									162414	08
38.1	36.76	4	924	1.1	4.2	1000	B									132416	09
32.7	42.76	3	809	1.2	3.6	1000	B									132414	10
31.1	45.00	3	851	1.2	3.5	1000	B									112416	11
26.8	52.33	3	990	1.0	3.0	1000	B									112414	12
24.6	56.82	2.2	791	1.1	2.3	850	B									82418	13
21.5	65.07	2.2	906	1.1	2.3	975	B									82416	14
18.5	75.68	2.2	1054	0.9	2.1	1000	B									82414	15
15.6	89.61	1.1	628	1.1	1.2	710	B									62416	16
13.4	104.22	1.1	731	1.1	1.2	820	B									62414	17

The dynamic efficiency is **0.94** for all ratios

Motor Flanges Available Flange Motore Disponibili
B) Supplied with Reduction Bushing Fornito con Bussola di Riduzione
B) Available on Request without reduction bushing Disponibile a Richiesta senza Bussola di Riduzione
C) Motor Flange Holes Position Posizione Fori Flangia Motore

EN Unit **X83C** is supplied without lubricant and equipped with a breather, level and drain plugs. User can add mineral oil keeping existing plugs. Should the user wish to fill it with synthetic oil, it is recommended to replace the existing plugs with a closed plug. See table 1 for lubrication and recommended quantity. In table 2 please see possible radial loads and axial loads on the gearbox.

I Il riduttore tipo **X83C** è fornito privo di lubrificazione con tappi di sfiato, livello e scarico olio. L'utente può immettere olio minerale mantenendo i tappi esistenti. Se immetterà olio sintetico, dovrà sostituire i tappi esistenti con altri tipo chiuso. Tab.1 per oli e quantità consigliati. Tab.2 carichi radiali e assiali applicabili al riduttore.

D Das Getriebe der Baugröße **X83C** wird ohne Schmiermittel geliefert. Es ist jedoch mit Einfüllschraube, Überdruckventil und Ablassschraube ausgerüstet. Das benötigte mineralische Öl kann über die Einfüllschraube eingefüllt werden. Sollte synthetisches Öl bevorzugt werden, so ist sind das eingebaute Überdruckventil durch eine geschlossenen Schraube zu ersetzen. In Tabelle 1 ist die Schmiermenge und das empfohlene Schmiermittel angegeben. In Tabelle 2 sind die zulässigen Radial - und Axialbelastungen des Getriebes aufgeführt.

F Le réducteur de type **X83C** est fourni sans lubrification et avec un bouchon de remplissage, de niveau et d'évacuation de l'huile. L'utilisateur peut y verser de l'huile minérale en conservant les bouchons existants. S'il y versera de l'huile synthétique, il devra substituer les bouchons existants avec d'autres bouchons de type fermé. Voir tableau 1 concernant les huiles et les quantités conseillées. Voir tableau 2 concernant les charges radiales et axiales applicables au réducteur.

E El reductor tamaño **X83C** se suministra sin lubricante, provisto de tapones de respiración, nivel y descarga de aceite. El usuario puede utilizar aceite mineral, manteniendo los tapones existentes. Si prefiere utilizar aceite sintético deberá sustituir los tapones existentes por tapones ciegos. La prerreducción se suministra con tapones ciegos, lubricado de por vida con aceite sintético. Ver tabla 1, para cantidades y aceites recomendados. En la tabla 2, se encuentran las cargas radiales y axiales admitidas por el reductor.

B3	B6	B7	B8	V5	V6	V8
2.80 LT	3.10 LT	2.00 LT	2.50 LT	4.95 LT	2.80 LT	Ask
SHELL Omala S2 GX 460				ENI Blasias 460		

For all details on lubrication and plugs check our website [www.angletech.com](#) **tab. 1**
Per maggiori dettagli su lubrificazione e tappi olio vedi il nostro sito web

RADIAL AND AXIAL LOADS

Output shaft
Albero di uscita

$F_{eq} = F_R \cdot \frac{196.5}{X + 156.5}$

F_R (N)
 F_A (N)

F_{eq} (N)

n_2	FA	FR	n_2	FA	FR	n_2	FA	FR
300	1700	8500	140	1860	9300	70	2160	10800
250	1760	8800	120	1900	9500	40	2300	11500
200	1800	9000	85	1960	9800	15	2400	12000

On request reinforced bearings to increase loads.
A richiesta cuscinetti rinforzati per aumentare i carichi.

Input shaft
Albero in entrata

n_1	FA	FR
1400	450	2250
900	500	2500
500	600	3000

tab. 2

PX83CC... Basic gearbox
Riduttore base

Gearbox weight
peso riduttore **48.5 kg**

M. flanges	Kit code	øF	A
71B5	K023.4.041	160	315.7
80/90B5	K023.4.042	200	317.7
100/112B5	K023.4.043	250	326.7
132B5	KC51.4.043	300	347.7
80B14	K085.4.046	120	317.7
90B14	K085.4.045	140	317.7
100/112B14	K085.4.047	160	326.7
132B14	KC51.4.041	200	347.7

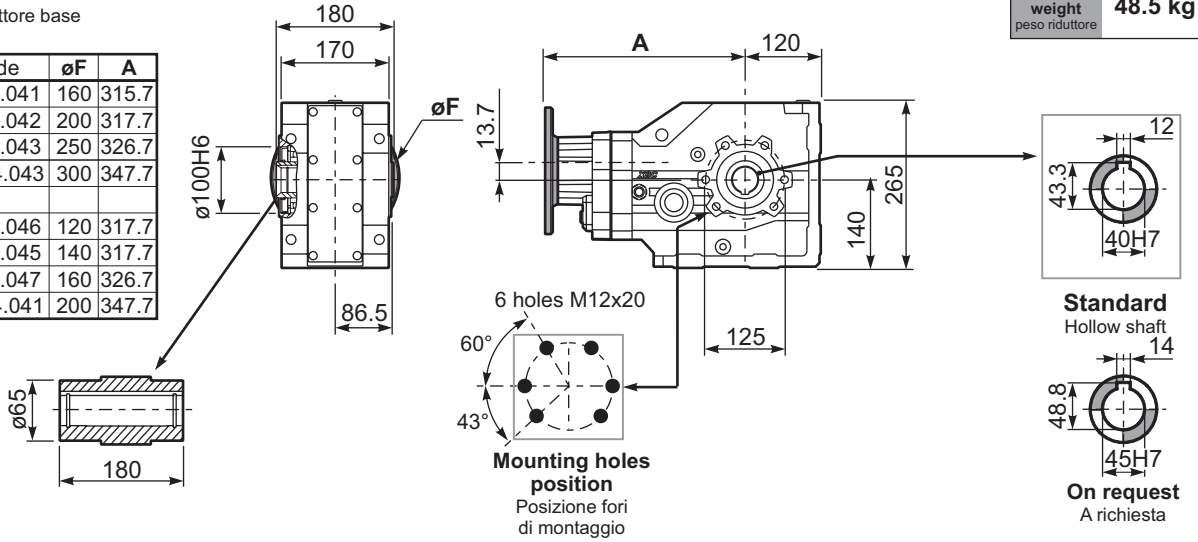

PX83C...FB.. Feet
Piedini

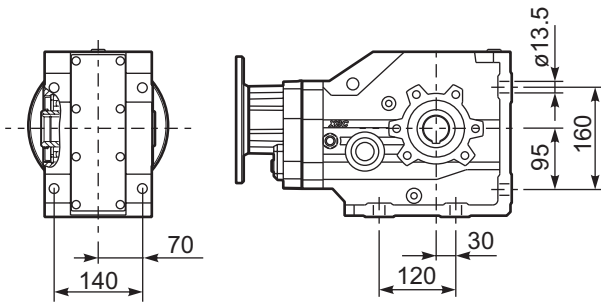

PX83C...-F4.. Output flange
Flangia uscita

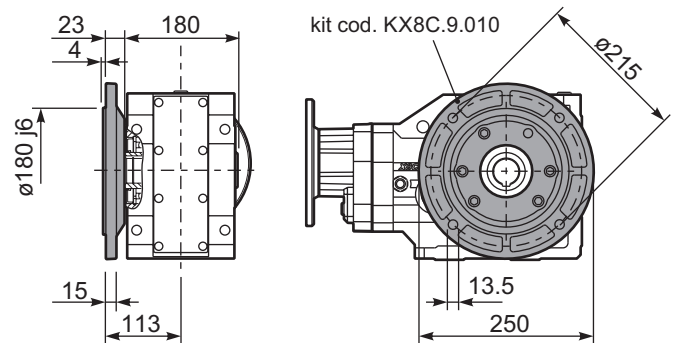

PX83C...BR.. Reaction Arm
Braccio di reazione

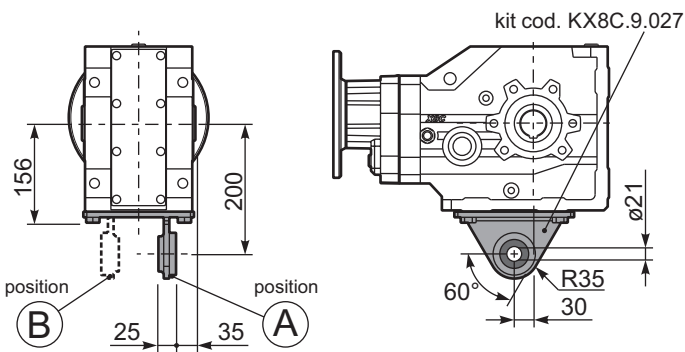

RX83C... Input shaft
Albero in entrata

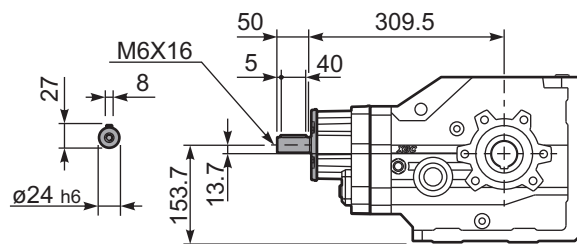

PX83CA... Single shaft
Albero lento semplice

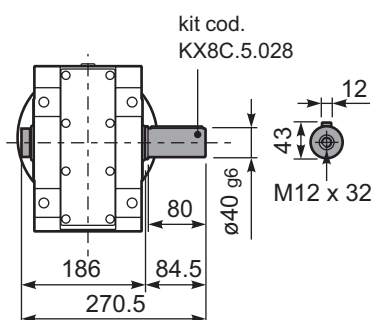

PX83CB... Double shaft
Albero lento bisp.

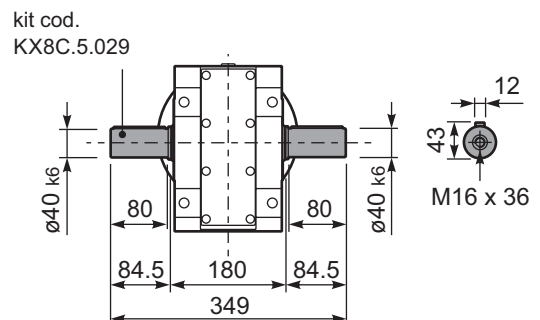

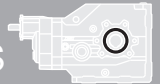

QUICK SELECTION / Selezione veloce

input speed (n_1) = 1400 min⁻¹

Output Speed n_2 [min ⁻¹]	Ratio i	Motor power P_{1M} [kW]	Output torque M_{2M} [Nm]	Service factor $f.s.$	Nominal power P_{1R} [kW]	Nominal torque M_{2R} [Nm]	Available B5 motor flanges				Available B14 motor flanges			Output Shaft 	Ratios code
							-B	-C	-D	-E	-Q	-R	-T		
							63	71	80	90	71	80	90		
15.3	91.23	1.5	858	1.2	1.7	1000	B				C	C		19132418	01
13.4	104.48	1.5	983	1.0	1.5	1000	B				C	C		19132416	02
11.6	121.10	1.5	1139	0.9	1.3	1000	B				C	C		17132416	03
9.9	140.84	1.1	968	1.0	1.1	1000	B				C	C		17132414	04
8.5	165.32	1.1	1136	0.9	0.96	1000	B				C	C		15132414	05
7.6	184.94	0.75	872	1.1	0.86	1000	B				C	C		19082416	06
7.1	197.34	0.75	930	1.1	0.81	1000	B				C	C		13132414	07
6.5	215.10	0.75	1014	1.0	0.74	1000	B				C	C		19082414	08
6.0	231.60	0.55	805	1.2	0.69	1000	B				C	C		10132416	09
5.6	249.31	0.55	867	1.2	0.64	1000	B				C	C		17082414	10
5.2	269.37	0.55	937	1.1	0.59	1000	B				C	C		10132414	11
4.8	292.64	0.55	1018	1.0	0.54	1000	B				C	C		15082414	12
4.6	302.26	0.55	1051	1.0	0.53	1000	B				C	C		9132416	13
4.0	349.30	0.37	812	1.2	0.46	1000	B				C	C		13082414	14
3.5	399.12	0.37	928	1.1	0.40	1000	B				C	C		7132416	15
2.9	476.80	0.37	1108	0.9	0.33	1000	B				C	C		10082414	16
2.2	622.28	0.25	976	1.0	0.26	1000	B				C	C		9082414	17
1.7	821.70	0.18	985	1.0	0.19	1000	B				C	C		7082414	18

The dynamic efficiency is **0.92** for all ratios

- Motor Flanges Available** Flange Motore Disponibili
- B) Supplied with Reduction Bushing** Fornito con Bussola di Riduzione
- B) Available on Request without reduction bushing** Disponibile a Richiesta senza Bussola di Riduzione
- C) Motor Flange Holes Position** Posizione Fori Flangia Motore

EN Unit **X84C** is supplied without lubricant and equipped with a breather, level and drain plugs. User can add mineral oil keeping existing plugs. Should the user wish to fill it with synthetic oil, it is recommended to replace the existing plugs with a closed plug. See table 1 for lubrication and recommended quantity. In table 2 please see possible radial loads and axial loads on the gearbox.

I Il riduttore tipo **X84C** è fornito privo di lubrificazione con tappi di sfiato, livello e scarico olio. L'utente può immettere olio minerale mantenendo i tappi esistenti. Se immetterà olio sintetico, dovrà sostituire i tappi esistenti con altri tipo chiuso. Tab.1 per oli e quantità consigliati. Tab.2 carichi radiali e assiali applicabili al riduttore.

D Das Getriebe der Baugröße **X84C** wird ohne Schmiermittel geliefert. Es ist jedoch mit Einfüllschraube, Überdruckventil und Ablassschraube ausgerüstet. Das benötigte mineralische Öl kann über die Einfüllschraube eingefüllt werden. Sollte synthetisches Öl bevorzugt werden, so ist sind das eingebaute Überdruckventil durch eine geschlossenen Schraube zu ersetzen. In Tabelle 1 ist die Schmiermenge und das empfohlene Schmiermittel angegeben. In Tabelle 2 sind die zulässigen Radial - und Axialbelastungen des Getriebes aufgeführt.

F Le réducteur de type **X84C** est fourni sans lubrification et avec un bouchon de remplissage, de niveau et d'évacuation de l'huile. L'utilisateur peut y verser de l'huile minérale en conservant les bouchons existants. S'il y versera de l'huile synthétique, il devra substituer les bouchons existants avec d'autres bouchons de type fermé. Voir tableau 1 concernant les huiles et les quantités conseillées. Voir tableau 2 concernant les charges radiales et axiales applicables au réducteur

E El reductor tamaño **X84C** se suministra sin lubricante, provisto de tapones de respiración, nivel y descarga de aceite. El usuario puede utilizar aceite mineral, manteniendo los tapones existentes. Si prefiere utilizar aceite sintético deberá sustituir los tapones existentes por tapones ciegos. La prerreducción se suministra con tapones ciegos, lubricado de por vida con aceite sintético. Ver tabla 1, para cantidades y aceites recomendados. En la tabla 2, se encuentran las cargas radiales y axiales admitidas por el reductor.

B3	B6	B7	B8	V5	V6	V8
4.25 LT	3.20 LT	2.10 LT	2.60 LT	5.20 LT	2.90 LT	Ask
SHELL Omala S2 GX 460				ENI Blasias 460		

For all details on lubrication and plugs check our website **tab. 1**
Per maggiori dettagli su lubrificazione e tappi olio vedi il nostro sito web

RADIAL AND AXIAL LOADS

Output shaft
Albero di uscita

$F_{eq} = FR \cdot \frac{196.5}{X+156.5}$

n_2	FA	FR	n_2	FA	FR	n_2	FA	FR
300	1700	8500	140	1860	9300	70	2160	10800
250	1760	8800	120	1900	9500	40	2300	11500
200	1800	9000	85	1960	9800	15	2400	12000

On request reinforced bearings to increase loads.
A richiesta cuscinetti rinforzati per aumentare i carichi.

Input shaft
Albero in entrata

n_1	FA	FR
1400	400	2000
900	440	2200
500	440	2200

tab. 2

PX84CC... Basic gearbox
Riduttore base

Gearbox weight
peso riduttore **46.5 kg**

M. flanges	Kit code	øF	A
63B5	K063.4.041	140	327.7
71B5	K063.4.042	160	325.7
80/90B5	K063.4.043	200	327.7
71B14	K063.4.047	105	325.7
80B14	K063.4.046	120	327.7
90B14	K063.4.041	140	327.7

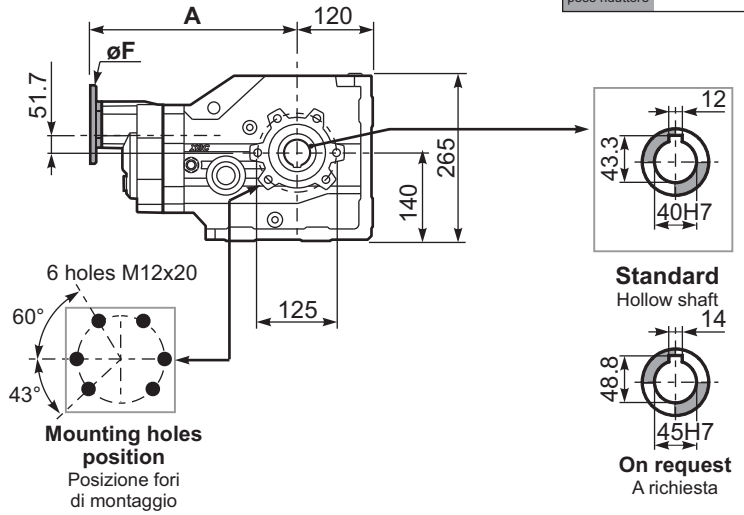
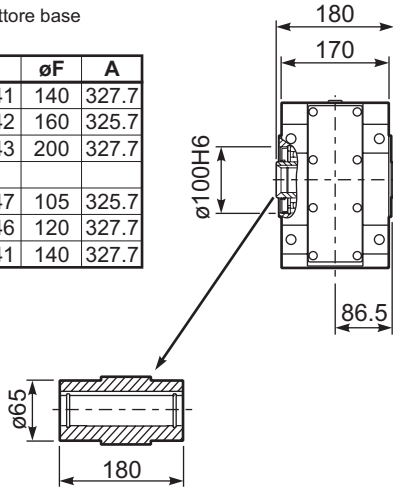

PX84C...FB.. Feet
Piedini

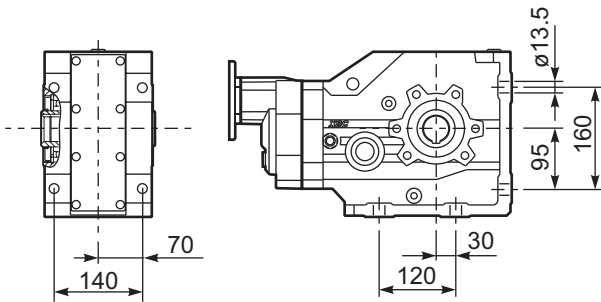

PX84C...-F4.. Output flange
Flangia uscita

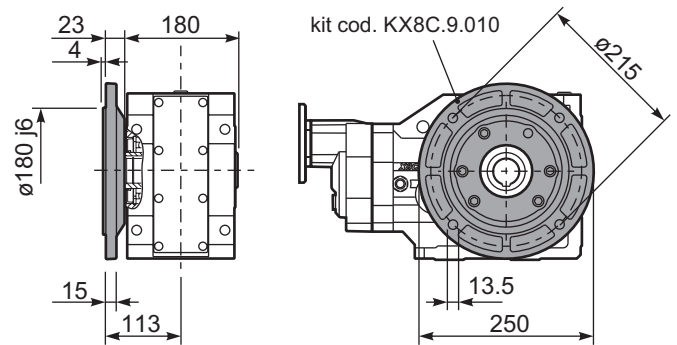

PX84C...BR.. Reaction Arm
Braccio di reazione

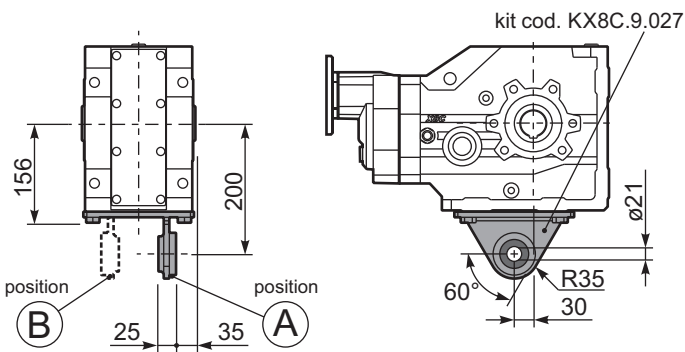

RX84C... Input shaft
Albero in entrata

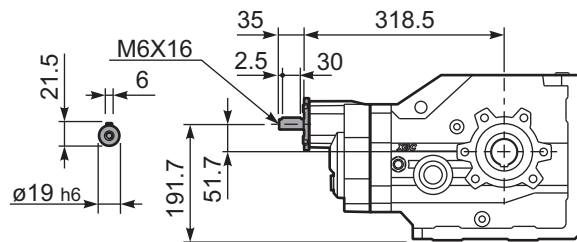

PX84CA... Single shaft
Albero lento semplice

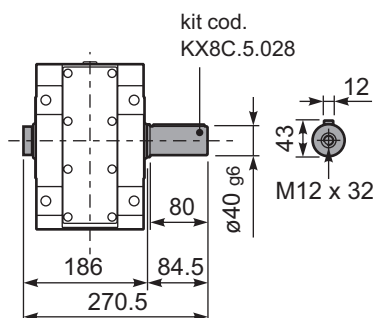

PX84CB... Double shaft
Albero lento bisp.

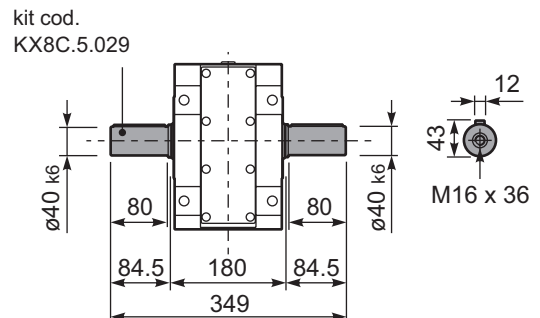

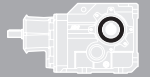

QUICK SELECTION / Selezione veloce

input speed (n₁) = 1400 min⁻¹

Output Speed n ₂ [min ⁻¹]	Ratio i	Motor power P _{1M} [kW]	Output torque M _{2M} [Nm]	Service factor f.s.	Nominal power P _{1R} [kW]	Nominal torque M _{2R} [Nm]	B5 motor flanges				B14 motor flanges		Output Shaft		
							-F	-G	-H	-I	-U	-V			Ratios code
							100 112	132	160	180	100 112	132			
236	5.94	22	806	1.0	21.0	800						302915		01	
196	7.13	18.5	812	1.0	17.9	820						302913		02	
163	8.58	18.5	977	1.0	17.3	950						302911		03	
125	11.20	15	1033	1.0	13.9	1000						202915		04	
104	13.43	15	1239	1.1	15.7	1350						202913		05	
92	15.15	15	1397	1.0	14.4	1400						162915	standard ø50	06	
87	16.17	15	1492	1.0	14.0	1450						202911			07
77	18.16	15	1675	0.9	13.3	1550						162913		08	
71	19.70	11	1335	1.2	12.3	1550						132915	ø45 On request	09	
64	21.87	11	1482	1.1	11.4	1600						162911			10
59	23.62	11	1600	1.0	10.6	1600						132913		11	
48.4	28.91	9	1671	1.0	8.6	1600						112913		12	
40.2	34.81	7.5	1618	1.0	7.2	1600						112911		13	
33.5	41.81	5.5	1436	1.1	6.0	1600						82913		14	
27.8	50.34	5.5	1729	0.9	5.0	1600						82911		15	

The dynamic efficiency is **0.94** for all ratios

- Motor Flanges Available Flange Motore Disponibili
- Supplied with Reduction Bushing Fornito con Bussola di Riduzione
- Available on Request without reduction bushing Disponibile a Richiesta senza Bussola di Riduzione
- Motor Flange Holes Position Posizione Fori Flangia Motore

EN Unit X93C is supplied without lubricant and equipped with a breather, level and drain plugs. User can add mineral oil keeping existing plugs. Should the user wish to fill it with synthetic oil, it is recommended to replace the existing plugs with a closed plug. See table 1 for lubrication and recommended quantity. In table 2 please see possible radial loads and axial loads on the gearbox.

I Il riduttore tipo X93C è fornito privo di lubrificazione con tappi di sfianto, livello e scarico olio. L'utente può immettere olio minerale mantenendo i tappi esistenti. Se immetterà olio sintetico, dovrà sostituire i tappi esistenti con altri tipo chiuso. Tab.1 per oli e quantità consigliati. Tab.2 carichi radiali e assiali applicabili al riduttore.

D Das Getriebe der Baugröße X93C wird ohne Schmiermittel geliefert. Es ist jedoch mit Einfüllschraube, Überdruckventil und Ablassschraube ausgerüstet. Das benötigte mineralische Öl kann über die Einfüllschraube eingefüllt werden. Sollte synthetisches Öl bevorzugt werden, so ist sind das eingebaute Überdruckventil durch eine geschlossenen Schraube zu ersetzen. In Tabelle 1 ist die Schmiermenge und das empfohlene Schmiermittel angegeben. In Tabelle 2 sind die zulässigen Radial - und Axialbelastungen des Getriebes aufgeführt.

F Le réducteur de type X93C est fourni sans lubrification et avec un bouchon de remplissage, de niveau et d'évacuation de l'huile. L'utilisateur peut y verser de l'huile minérale en conservant les bouchons existants. S'il y versera de l'huile synthétique, il devra substituer les bouchons existants avec d'autres bouchons de type fermé. Voir tableau 1 concernant les huiles et les quantités conseillées. Voir tableau 2 concernant les charges radiales et axiales applicables au réducteur

E El reductor tamaño X93C se suministra sin lubricante, provisto de tapones de respiración, nivel y descarga de aceite. El usuario puede utilizar aceite mineral, manteniendo los tapones existentes. Si prefiere utilizar aceite sintético deberá sustituir los tapones existentes por tapones ciegos. La prerreducción se suministra con tapones ciegos, lubricado de por vida con aceite sintético. Ver tabla 1, para cantidades y aceites recomendados. En la tabla 2, se encuentran las cargas radiales y axiales admitidas por el reductor.

Standard supplied	For these mounting position specify in the order or add oil					
	Per queste posizioni specificare in fase d'ordine o aggiungere olio					
B3	B6	B7	B8	V5	V6	V8
4.20 LT	3.60 LT	4.40 LT	5.10 LT	6.90 LT	5.00 LT	Ask
SHELL Omala S2 GX 460				ENI Blasias 460		

For all details on lubrication and plugs check our website **tab. 1**
Per maggiori dettagli su lubrificazione e tappi olio vedi il nostro sito web

RADIAL AND AXIAL LOADS

Output shaft
Albero di uscita

$$F_{eq} = F_R \cdot \frac{218}{X+168}$$

n ₂	FA	FR	n ₂	FA	FR	n ₂	FA	FR
300	1800	9000	140	2700	13500	70	3020	15100
250	2400	12000	120	2800	14000	40	3200	16000
200	2600	13000	85	2900	14500	15	3500	17500

Input shaft
Albero in entrata

n ₁	FA	FR
1400	700	3500
900	840	4200
500	900	4500

tab. 2

PX93CC... Basic Gearbox
Riduttore base

Gearbox weight
peso riduttore **75.0 kg**

M. flanges	Kit code	øF	A
100/112B5	K023.4.043	250	342.5
132B5	KC51.4.043C	300	364
160/180B5	KC86.4.0.43	350	396
100/112B14	K085.4.047	160	342.5
132B14	KC51.4.041C	200	364

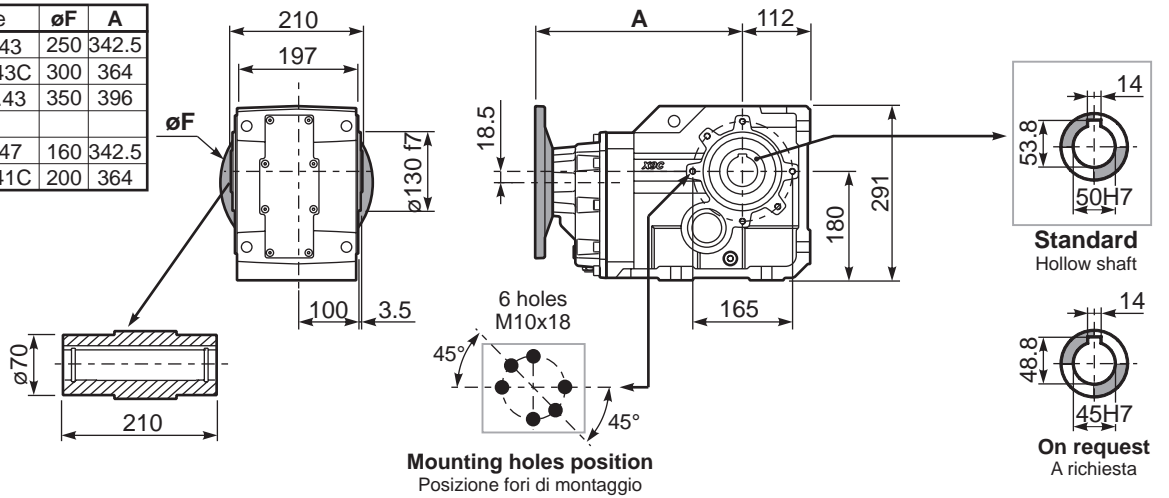

Mounting holes position
Posizione fori di montaggio

PX93C...FB.. Feet
Piedini

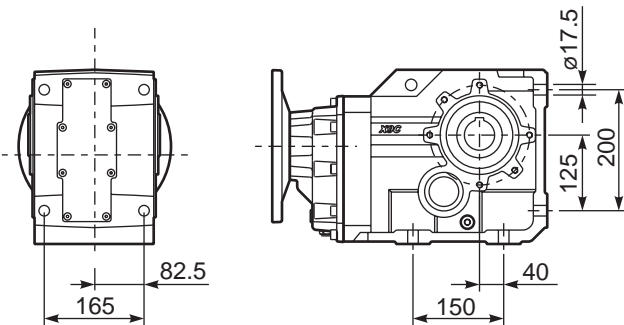

PX93C...-FC.. Output flange
Flangia uscita

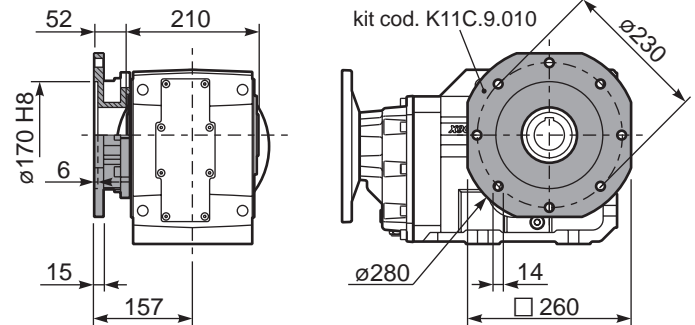

PX93C...-FL.. Output flange
Flangia uscita

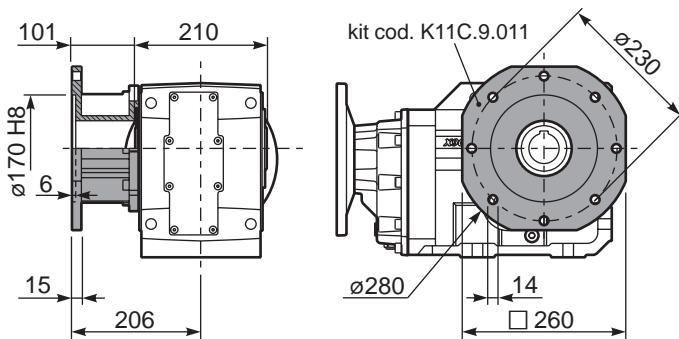

PX93C...BR.. Reaction Arm
Braccio di reazione

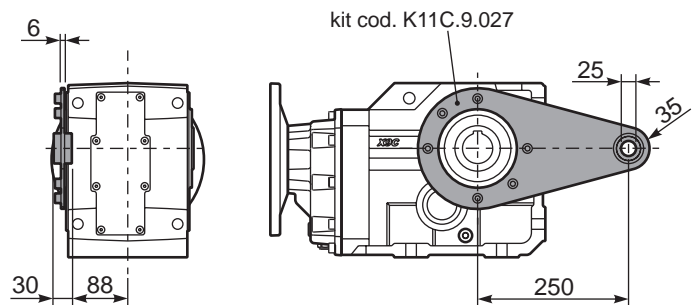

RX93C... Input shaft
Albero in entrata

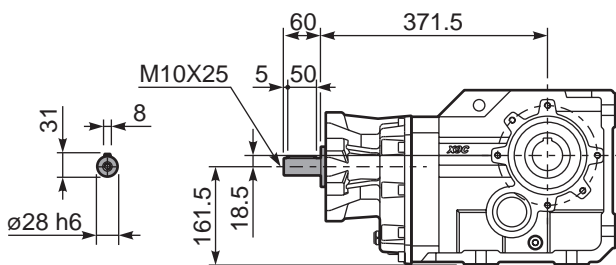

PX93CA... Single shaft
Albero lento semplice

PX93CB... Double shaft
Albero lento bisp.

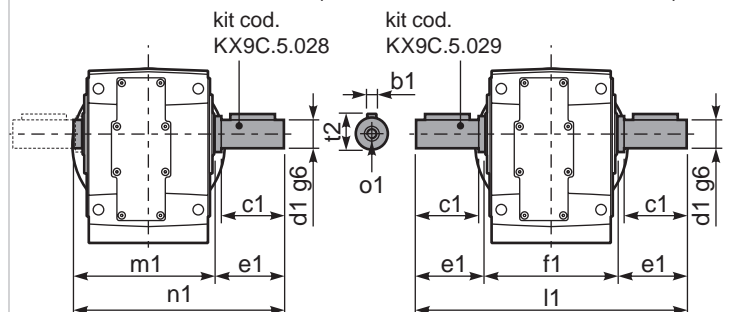

	b1	c1	d1	e1	f1	l1	m1	n1	t2	o1
Standard	14	100	50	105	210	420	218	323	53.5	M16
-	-	-	-	-	-	-	-	-	-	-



QUICK SELECTION / Selezione veloce

input speed (n₁) = 1400 min⁻¹

Output Speed n ₂ [min ⁻¹]	Ratio i	Motor power P _{1M} [kW]	Output torque M _{2M} [Nm]	Service factor f.s.	Nominal power P _{1R} [kW]	Nominal torque M _{2R} [Nm]	Available B5 motor flanges					Available B14 motor flanges				Output Shaft 	Ratios code
							-C	-D	-E	-F	-G	-R	-T	-U	-V		
							71	80	90	100 112	132	80	90	100 112	132		
45.6	30.70	7.5	1399	1.1	8.3	1600	B									30132913	01
37.9	36.97	7.5	1685	0.9	6.9	1600	B									30132911	02
29.0	48.26	5.5	1625	1.0	5.3	1600	B									20132915	03
24.2	57.86	4	1425	1.1	4.4	1600	B									20132913	04
21.5	65.24	4	1607	1.0	3.9	1600	B									16132915	05
20.1	69.68	4	1716	1.0	3.8	1650	B									20132911	06
17.9	78.23	3	1450	1.1	3.4	1650	B									16132913	07
16.5	84.85	3	1573	1.0	3.0	1600	B									13132915	08
14.9	94.20	3	1747	0.9	2.8	1650	B									16132911	09
13.8	101.74	3	1886	0.9	2.6	1650	B									13132913	10
11.4	122.51	2.2	1672	1.0	2.1	1650	B									13132911	11
9.3	149.95	1.5	1411	1.2	1.8	1650	B									11132911	12
7.8	180.09	1.5	1694	1.0	1.5	1650	B									8132913	13
6.8	206.81	1.1	1421	1.1	1.2	1600	B									6132915	14
6.5	216.85	1.1	1490	1.1	1.2	1650	B									8132911	15
5.6	247.99	1.1	1704	1.0	1.1	1650	B									6132913	16
4.7	298.61	0.75	1407	1.2	0.88	1650	B									6132911	17

The dynamic efficiency is **0.92** for all ratios

Motor Flanges Available
Flange Motore Disponibili

Supplied with Reduction Bushing
Fornito con Bussola di Riduzione

Available on Request without reduction bushing
Disponibile a Richiesta senza Bussola di Riduzione

Motor Flange Holes Position
Posizione Fori Flangia Motore

EN Unit **X94C** is supplied without lubricant and equipped with a breather, level and drain plugs. User can add mineral oil keeping existing plugs. Should the user wish to fill it with synthetic oil, it is recommended to replace the existing plugs with a closed plug.
See table 1 for lubrication and recommended quantity.
In table 2 please see possible radial loads and axial loads on the gearbox.

I Il riduttore tipo **X94C** è fornito privo di lubrificazione con tappi di sfiato, livello e scarico olio. L'utente può immettere olio minerale mantenendo i tappi esistenti. Se immetterà olio sintetico, dovrà sostituire i tappi esistenti con altri tipo chiuso.
Tab.1 per oli e quantità consigliati.
Tab.2 carichi radiali e assiali applicabili al riduttore.

D Das Getriebe der Baugröße **X94C** wird ohne Schmiermittel geliefert. Es ist jedoch mit Einfüllschraube, Überdruckventil und Ablassschraube ausgerüstet. Das benötigte mineralische Öl kann über die Einfüllschraube eingefüllt werden. Sollte synthetisches Öl bevorzugt werden, so ist sind das eingebaute Überdruckventil durch eine geschlossenen Schraube zu ersetzen.
In Tabelle 1 ist die Schmiermenge und das empfohlene Schmiermittel angegeben
In Tabelle 2 sind die zulässigen Radial - und Axialbelastungen des Getriebes aufgeführt.

F Le réducteur de type **X94C** est fourni sans lubrification et avec un bouchon de remplissage, de niveau et d'évacuation de l'huile. L'utilisateur peut y verser de l'huile minérale en conservant les bouchons existants. S'il y versera de l'huile synthétique, il devra substituer les bouchons existants avec d'autres bouchons de type fermé.
Voir tableau 1 concernant les huiles et les quantités conseillées.
Voir tableau 2 concernant les charges radiales et axiales applicables au réducteur

E El reductor tamaño **X94C** se suministra sin lubricante, provisto de tapones de respiración, nivel y descarga de aceite. El usuario puede utilizar aceite mineral, manteniendo los tapones existentes. Si prefiere utilizar aceite sintético deberá sustituir los tapones existentes por tapones ciegos. La prerreducción se suministra con tapones ciegos, lubricado de por vida con aceite sintético. Ver tabla 1, para cantidades y aceites recomendados. En la tabla 2, se encuentran las cargas radiales y axiales admitidas por el reductor.

Standard supplied	For these mounting position specify in the order or add oil Per queste posizioni specificare in fase d'ordine o aggiungere olio					
B3	B6	B7	B8	V5	V6	V8
4.50 LT	3.80 LT	4.50 LT	5.30 LT	7.60 LT	5.30 LT	Ask
SHELL Omala S2 GX 460				ENI Blasia 460		

For all details on lubrication and plugs check our website **tab. 1**
Per maggiori dettagli su lubrificazione e tappi olio vedi il nostro sito web

RADIAL AND AXIAL LOADS

Output shaft
Albero di uscita

$$F_{eq} = F_R \cdot \frac{218}{X+168}$$

n ₂	FA	FR	n ₂	FA	FR	n ₂	FA	FR
300	1800	9000	140	2700	13500	70	3020	15100
250	2400	12000	120	2800	14000	40	3200	16000
200	2600	13000	85	2900	14500	15	3500	17500

Input shaft

Albero in entrata

tab. 2

PX94CC... Basic Gearbox
Riduttore base

Gearbox weight **68.5 kg**
peso riduttore

M. flanges	Kit code	øF	A
71B5	K023.4.041	160	336
80/90B5	K023.4.042	200	338
100/112B5	K023.4.043	250	347
132B5	KC51.4.043	300	368
80B14	K085.4.046	120	338
90B14	K085.4.045	140	338
100/112B14	K085.4.047	160	347
132B14	KC51.4.041	200	368

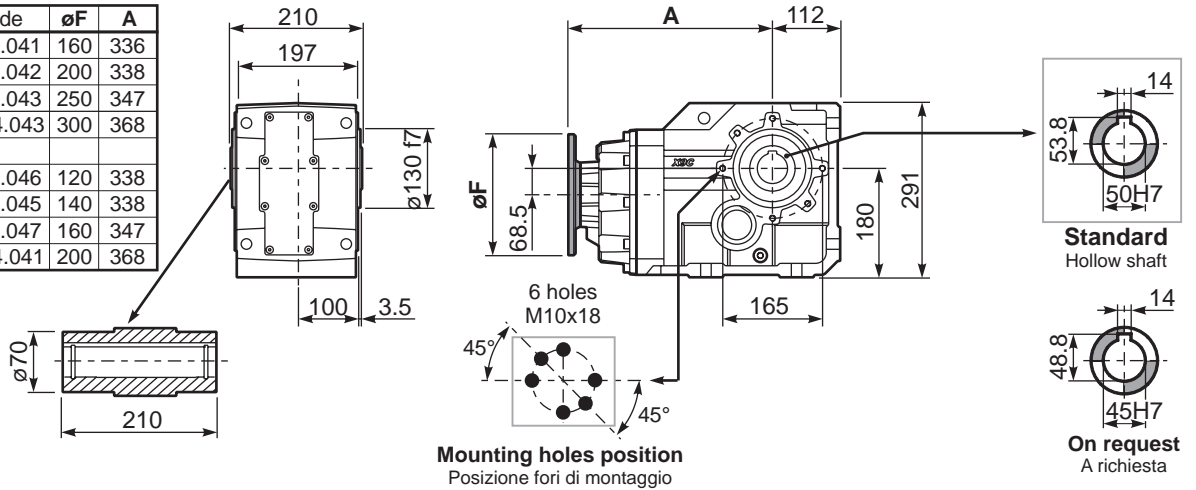

PX94C...FB.. Feet
Piedini

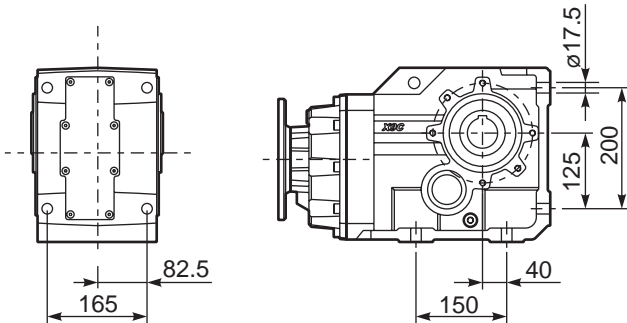

PX94C...-FC.. Output flange
Flangia uscita

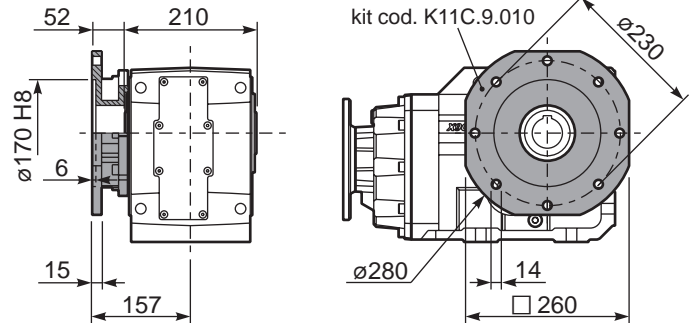

PX94C...-FL.. Output flange
Flangia uscita

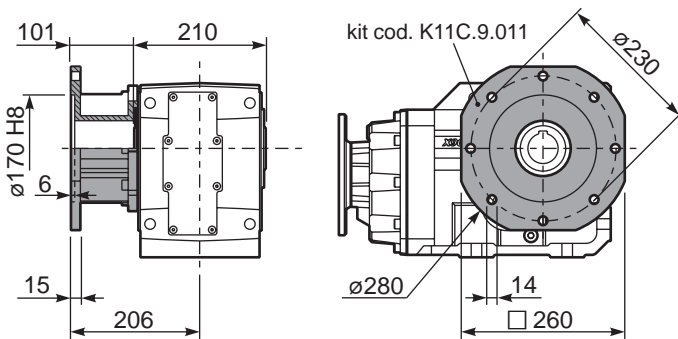

PX94C...BR.. Reaction Arm
Braccio di reazione

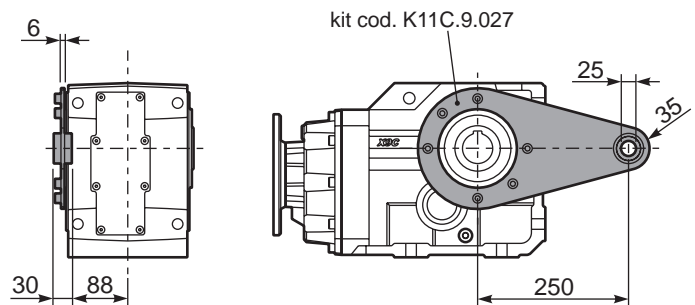

RX94C... Input shaft
Albero in entrata

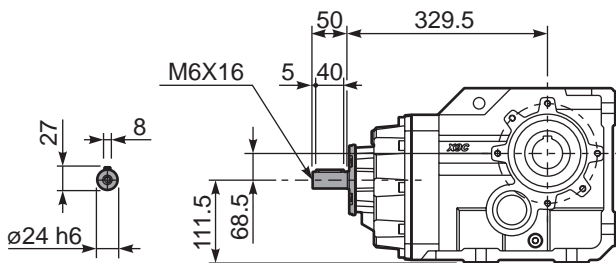

PX94CA... Single shaft
Albero lento semplice

PX94CB... Double shaft
Albero lento bisp.

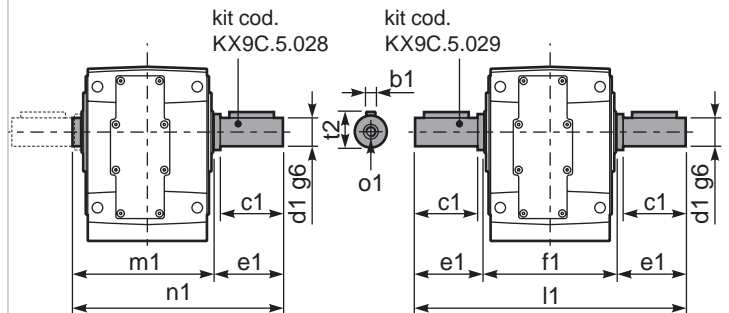

	b1	c1	d1	e1	f1	l1	m1	n1	t2	o1
Standard	14	100	50	105	210	420	218	323	53.5	M16
-	-	-	-	-	-	-	-	-	-	-



QUICK SELECTION / Selezione veloce

input speed (n₁) = 1400 min⁻¹

Output Speed n ₂ [min ⁻¹]	Ratio i	Motor power P _{1M} [kW]	Output torque M _{2M} [Nm]	Service factor f.s.	Nominal power P _{1R} [kW]	Nominal torque M _{2R} [Nm]	B5 motor flanges				B14 motor flanges				Output Shaft			
							-G	-H	-I	-L	-	-	-	-			Ratios code	
							132	160	180	200	-	-	-	-				
219	6.39	30	1180	1.1	31.7	1300												01
200	7.00	30	1292	1.1	31.2	1400												02
164	8.55	30	1578	1.0	27.4	1500												03
140	10.01	22	1357	1.2	24.9	1600												04
128	10.97	22	1486	1.1	24.2	1700												05
105	13.39	22	1815	1.2	24.5	2100												06
89	15.71	22	2130	1.0	21.8	2200												07
81	17.21	22	2333	1.0	20.8	2300												08
67	21.02	18.5	2394	1.0	17.8	2400												09
59	23.73	18.5	2703	1.0	17.1	2600												10
54	25.99	18.5	2960	0.9	16.8	2800												11
50	27.93	15	2576	1.1	16.2	2900												12
45.8	30.59	15	2822	1.0	14.8	2900												13
44.1	31.74	15	2928	1.0	14.2	2900												14
37.5	37.36	11	2532	1.1	12.1	2900												15
33.8	41.37	11	2804	1.0	10.9	2900												16
30.9	45.31	9	2618	1.1	10.0	2900												17
25.3	55.33	7.5	2573	1.2	8.5	3000												18

The dynamic efficiency is **0.94** for all ratios

- Motor Flanges Available Flange Motore Disponibili
- Supplied with Reduction Bushing Fornito con Bussola di Riduzione
- Available on Request without reduction bushing Disponibile a Richiesta senza Bussola di Riduzione
- Motor Flange Holes Position Posizione Fori Flangia Motore

EN Unit X103 is supplied without lubricant and equipped with a breather, level and drain plugs. User can add mineral oil keeping existing plugs. Should the user wish to fill it with synthetic oil, it is recommended to replace the existing plugs with a closed plug. See table 1 for lubrication and recommended quantity. In table 2 please see possible radial loads and axial loads on the gearbox.

I Il riduttore tipo X103 è fornito privo di lubrificazione con tappi di sfiato, livello e scarico olio. L'utente può immettere olio minerale mantenendo i tappi esistenti. Se immetterà olio sintetico, dovrà sostituire i tappi esistenti con altri tipo chiuso. Tab.1 per oli e quantità consigliati. Tab.2 carichi radiali e assiali applicabili al riduttore.

D Das Getriebe der Baugröße X103 wird ohne Schmiermittel geliefert. Es ist jedoch mit Einfüllschraube, Überdruckventil und Ablassschraube ausgerüstet. Das benötigte mineralische Öl kann über die Einfüllschraube eingefüllt werden. Sollte synthetisches Öl bevorzugt werden, so ist sind das eingebaute Überdruckventil durch eine geschlossenen Schraube zu ersetzen. In Tabelle 1 ist die Schmiermenge und das empfohlene Schmiermittel angegeben. In Tabelle 2 sind die zulässigen Radial - und Axialbelastungen des Getriebes aufgeführt.

F Le réducteur de type X103 est fourni sans lubrification et avec un bouchon de remplissage, de niveau et d'évacuation de l'huile. L'utilisateur peut y verser de l'huile minérale en conservant les bouchons existants. S'il y versera de l'huile synthétique, il devra substituer les bouchons existants avec d'autres bouchons de type fermé. Voir tableau 1 concernant les huiles et les quantités conseillées. Voir tableau 2 concernant les charges radiales et axiales applicables au réducteur

E El reductor tamaño X103 se suministra sin lubricante, provisto de tapones de respiración, nivel y descarga de aceite. El usuario puede utilizar aceite mineral, manteniendo los tapones existentes. Si prefiere utilizar aceite sintético deberá sustituir los tapones existentes por tapones ciegos. La prerreducción se suministra con tapones ciegos, lubricado de por vida con aceite sintético. Ver tabla 1, para cantidades y aceites recomendados. En la tabla 2, se encuentran las cargas radiales y axiales admitidas por el reductor.

Standard supplied	For these mounting position specify in the order or add oil					
	Per queste posizioni specificare in fase d'ordine o aggiungere olio					
B3	B6	B7	B8	V5	V6	V8
11.50 LT	5.50 LT	10.50 LT	7.50 LT	13.50 LT	9.50 LT	Ask
SHELL Omala S2 GX 460				ENI Blasias 460		

For all details on lubrication and plugs check our website [tab. 1](#)
Per maggiori dettagli su lubrificazione e tappi olio vedi il nostro sito web

RADIAL AND AXIAL LOADS

Output shaft
Albero di uscita

$F_{eq} = F_R \cdot \frac{253}{X+193}$

n ₂	FA	FR	n ₂	FA	FR	n ₂	FA	FR
300	2000	10000	140	2800	14000	70	3500	17500
250	2500	12500	120	3000	15000	40	4200	21000
200	2700	13500	85	3200	16000	15	5400	27000

Input shaft
Albero in entrata

n ₁	FA	FR
1400	1120	5600
900	1220	6100
500	1300	6500

tab. 2

PX103C... Basic Gearbox
Riduttore base

Gearbox weight **125 kg**
peso riduttore

M. flanges	Kit code	øF	A
132B5	KC110.9.052	300	486.5
160B5	KC110.9.053	350	511.5
180B5	KC110.9.053_B	350	511.5
200B5	KC110.9.054	400	511.5

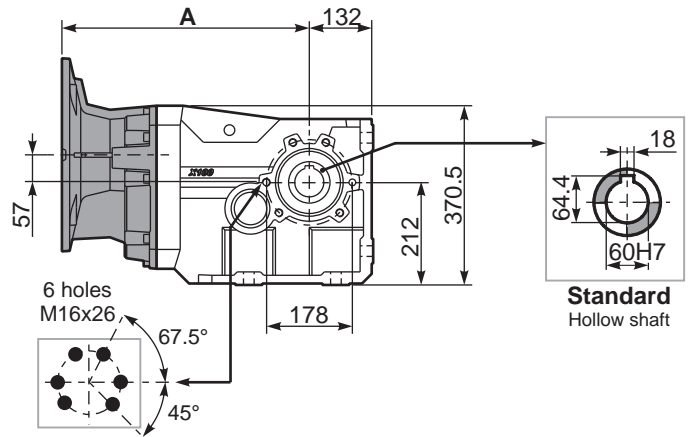
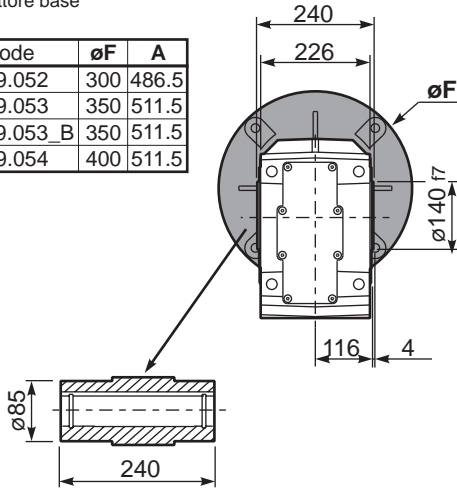

Mounting holes position
Posizione fori di montaggio

PX103...FB.. Feet
Piedini

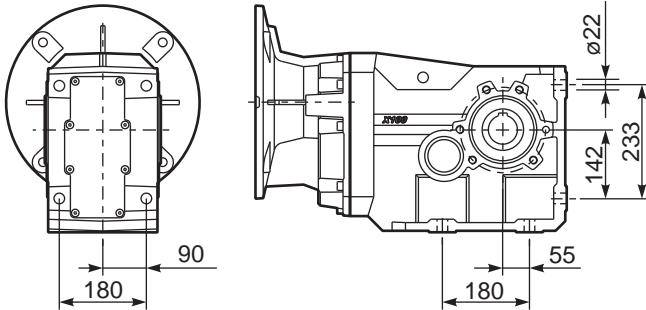

PX103...-F6.. Output flange
Flangia uscita

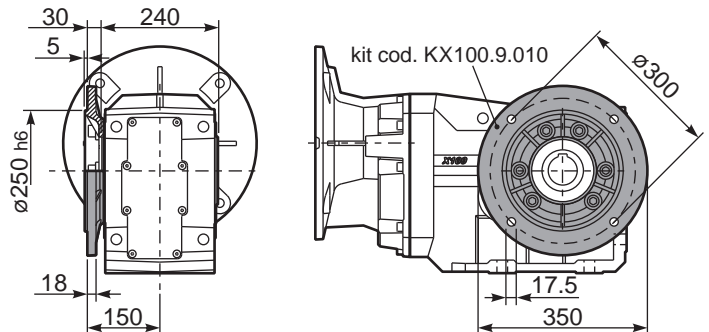

PX103...BR.. Reaction Arm
Braccio di reazione

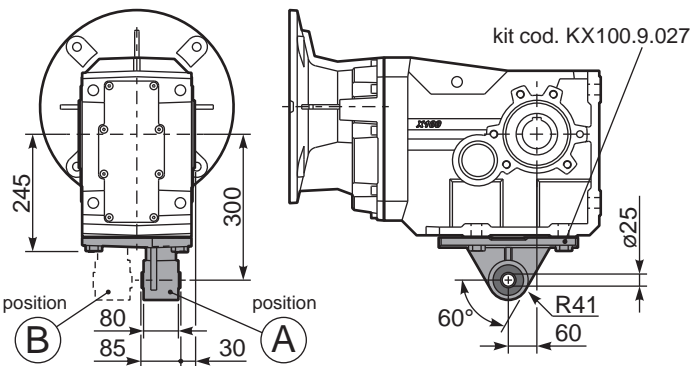

RX103... Input shaft
Albero in entrata

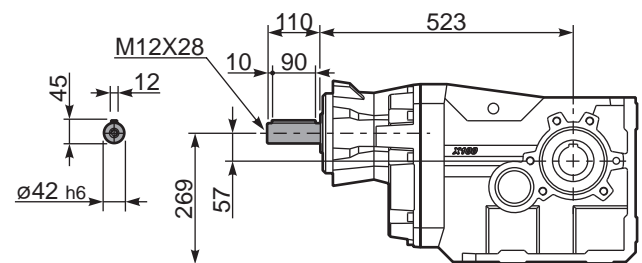

PX103A... Single shaft
Albero lento semplice

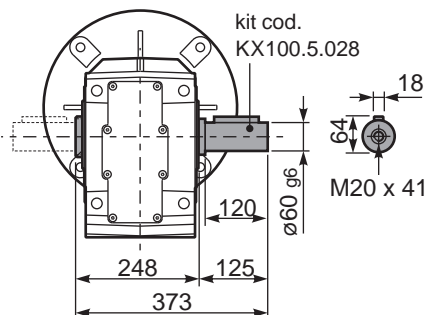

PX103B... Double shaft
Albero lento bisp.

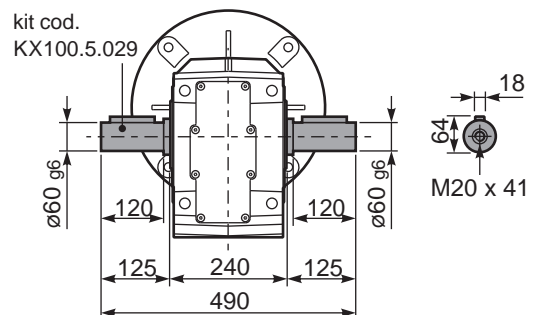

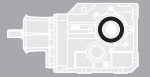

QUICK SELECTION / Selezione veloce

input speed (n₁) = 1400 min⁻¹

Output Speed n ₂ [min ⁻¹]	Ratio i	Motor power P _{1M} [kW]	Output torque M _{2M} [Nm]	Service factor f.s.	Nominal power P _{1R} [kW]	Nominal torque M _{2R} [Nm]	Available B5 motor flanges		B14 motor flanges		Output Shaft 	Ratios code
							-F	-G	-U	-V		
							100 112	132	100 112	132		
28.8	48.57	9	2750	1.1	9.5	2900					30142911	01
20.5	68.43	7.5	3118	1.0	7.0	3000					20142914	02
18.7	74.95	5.5	2523	1.2	6.4	3000					20142913	03
15.1	92.53	5.5	3115	1.0	5.2	3000					16142914	04
13.8	101.33	4	2496	1.2	4.7	3000					16142913	05
11.6	120.33	4	2963	1.0	4.0	3000					13142914	06
11.3	123.75	4	3048	1.0	3.9	3000					16142911	07
10.6	131.78	4	3245	0.9	3.6	3000					13142913	08
9.5	147.28	3	2731	1.1	3.2	3000					11142914	09
8.7	161.30	3	2990	1.0	3.0	3000					11142913	10
7.1	196.98	2.2	2689	1.1	2.4	3000					11142911	11
6.6	212.99	2.2	2907	1.0	2.2	3000					8142914	12
6.0	233.26	2.2	3184	0.9	2.0	3000					8142913	13
4.9	284.86	2.2	3889	0.8	1.7	3000					8142911	14

The dynamic efficiency is **0.92** for all ratios

Motor Flanges Available
Flange Motore Disponibili

B) Supplied with Reduction Bushing
Fornito con Bussola di Riduzione

B) Available on Request without reduction bushing
Disponibile a Richiesta senza Bussola di Riduzione

C) Motor Flange Holes Position
Posizione Fori Flangia Motore

EN Unit **X104** is supplied without lubricant and equipped with a breather, level and drain plugs. User can add mineral oil keeping existing plugs. Should the user wish to fill it with synthetic oil, it is recommended to replace the existing plugs with a closed plug. See table 1 for lubrication and recommended quantity. In table 2 please see possible radial loads and axial loads on the gearbox.

I Il riduttore tipo **X104** è fornito privo di lubrificazione con tappi di sfiato, livello e scarico olio. L'utente può immettere olio minerale mantenendo i tappi esistenti. Se immetterà olio sintetico, dovrà sostituire i tappi esistenti con altri tipo chiuso. Tab.1 per oli e quantità consigliati. Tab.2 carichi radiali e assiali applicabili al riduttore.

D Das Getriebe der Baugröße **X104** wird ohne Schmiermittel geliefert. Es ist jedoch mit Einfüllschraube, Überdruckventil und Ablassschraube ausgerüstet. Das benötigte mineralische Öl kann über die Einfüllschraube eingefüllt werden. Sollte synthetisches Öl bevorzugt werden, so ist sind das eingebaute Überdruckventil durch eine geschlossenen Schraube zu ersetzen. In Tabelle 1 ist die Schmiermenge und das empfohlene Schmiermittel angegeben. In Tabelle 2 sind die zulässigen Radial - und Axialbelastungen des Getriebes aufgeführt.

F Le réducteur de type **X104** est fourni sans lubrification et avec un bouchon de remplissage, de niveau et d'évacuation de l'huile. L'utilisateur peut y verser de l'huile minérale en conservant les bouchons existants. S'il y versera de l'huile synthétique, il devra substituer les bouchons existants avec d'autres bouchons de type fermé. Voir tableau 1 concernant les huiles et les quantités conseillées. Voir tableau 2 concernant les charges radiales et axiales applicables au réducteur.

E El reductor tamaño **X104** se suministra sin lubricante, provisto de tapones de respiración, nivel y descarga de aceite. El usuario puede utilizar aceite mineral, manteniendo los tapones existentes. Si prefiere utilizar aceite sintético deberá sustituir los tapones existentes por tapones ciegos. La prerreducción se suministra con tapones ciegos, lubricado de por vida con aceite sintético. Ver tabla 1, para cantidades y aceites recomendados. En la tabla 2, se encuentran las cargas radiales y axiales admitidas por el reductor.

Standard supplied	For these mounting position specify in the order or add oil					
	Per queste posizioni specificare in fase d'ordine o aggiungere olio					
B3	B6	B7	B8	V5	V6	V8
12.00 LT	6.00 LT	11.50 LT	8.00 LT	14.50 LT	11.00 LT	Ask
SHELL Omala S2 GX 460			ENI Blasias 460			

For all details on lubrication and plugs check our website **tab. 1**
Per maggiori dettagli su lubrificazione e tappi olio vedi il nostro sito web

RADIAL AND AXIAL LOADS

Output shaft
Albero di uscita

$$F_{eq} = F_R \cdot \frac{253}{X+193}$$

n ₂	FA	FR	n ₂	FA	FR	n ₂	FA	FR
300	2000	10000	140	2800	14000	70	3500	17500
250	2500	12500	120	3000	15000	40	4200	21000
200	2700	13500	85	3200	16000	15	5400	27000

Input shaft
Albero in entrata

n ₁	FA	FR
1400	700	3500
900	840	4200
500	900	4500

tab. 2

PX104C... Basic Gearbox
Riduttore base

Gearbox weight **118 kg**
peso riduttore

M. flanges	Kit code	øF	A
100/112B5	K023.4.043	250	479
132B5	KC51.4.043C	300	500.5
100/112B14	K085.4.047	160	479
132B14	KC51.4.041C	200	500.5

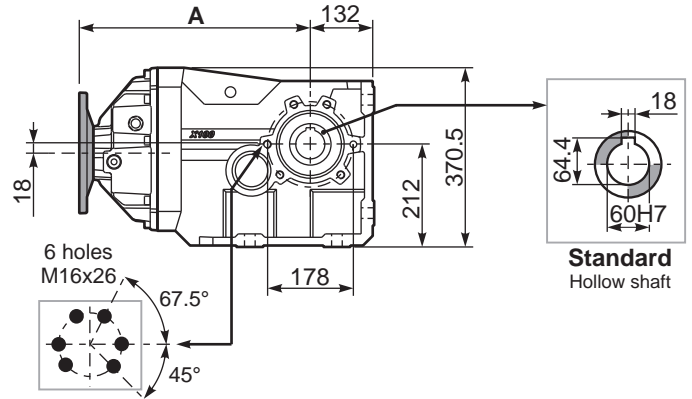
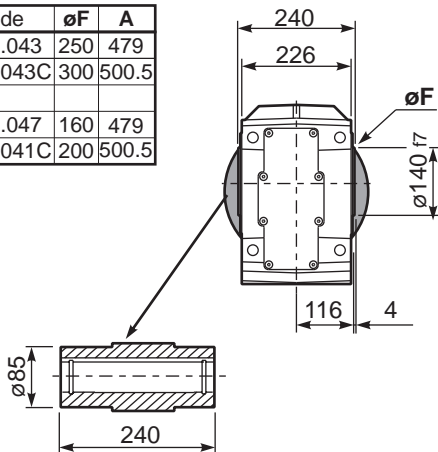

Mounting holes position
Posizione fori di montaggio

PX104...FB.. Feet
Piedini

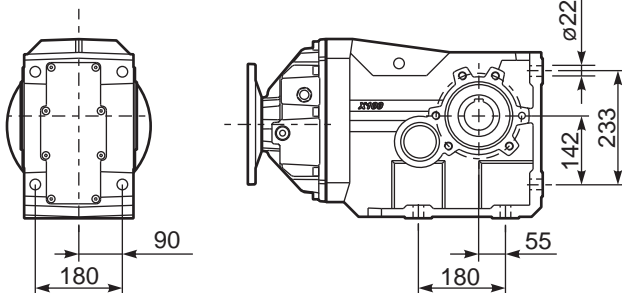

PX104...-F6.. Output flange
Flangia uscita

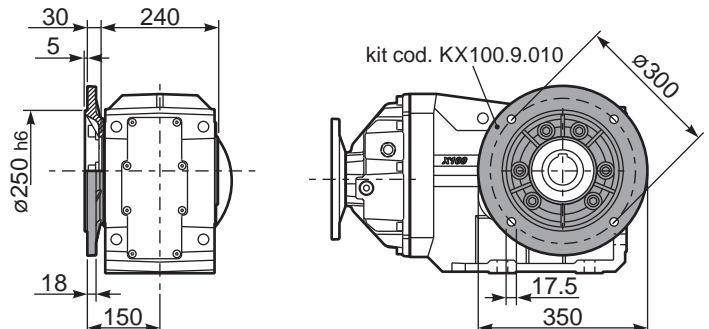

PX104...BR.. Reaction Arm
Braccio di reazione

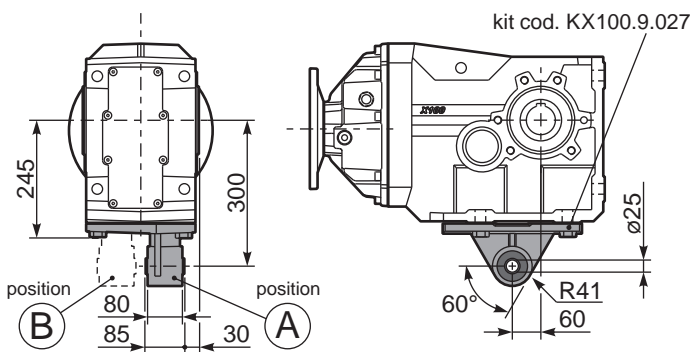

RX104... Input shaft
Albero in entrata

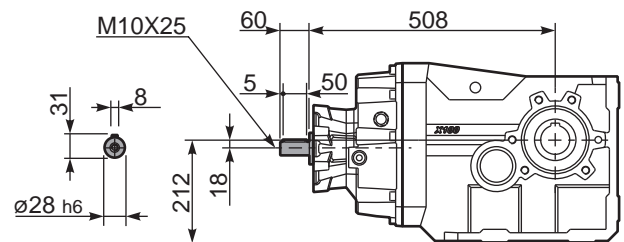

PX104A... Single shaft
Albero lento semplice

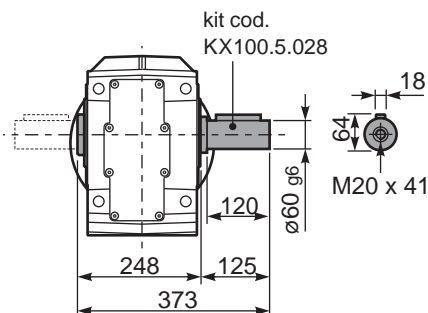

PX104B... Double shaft
Albero lento bisp.

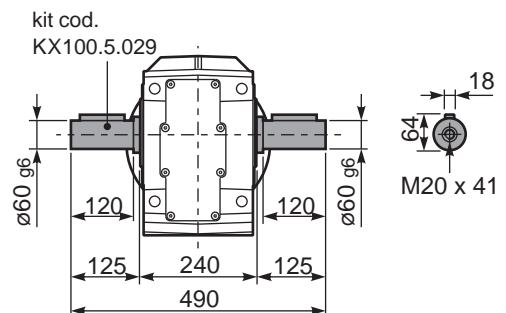



QUICK SELECTION / Selezione veloce

input speed (n_1) = 1400 min⁻¹

Output Speed n_2 [min ⁻¹]	Ratio i	Motor power P_{1M} [kW]	Output torque M_{2M} [Nm]	Service factor f.s.	Nominal power P_{1R} [kW]	Nominal torque M_{2R} [Nm]	B5 motor flanges					B14 motor flanges			Output Shaft				
							-G	-H	-I	-L	CA	-	-	-					
							132	160	180	200	225	-	-	-			Ratio code		
219	6.39	45	1757	1.4	61.0	2500											392914		01
200	7.00	45	1925	1.4	59.0	2650											392913		02
164	8.55	45	2350	1.2	51.1	2800											392911		03
140	10.01	45	2752	1.2	49.8	3200											302914		04
128	10.97	45	3014	1.1	45.5	3200											302913		05
105	13.39	37	3025	1.1	39.6	3400											302911		06
89	15.71	37	3550	1.0	34.7	3500											222914		07
81	17.21	37	3888	1.0	33.5	3700											222913		08
67	21.02	30	3877	1.0	29.7	4000											222911	standard ø70	09
59	23.73	30	4378	0.9	26.9	4100											162914		10
54	25.99	22	3523	1.2	25.8	4300											162913		11
50	27.93	22	3786	1.1	24.0	4300											142914		12
45.8	30.59	22	4146	1.1	22.9	4500											142913		13
44.1	31.74	22	4302	1.0	22.1	4500											162911		14
37.5	37.36	18.5	4255	1.1	18.8	4500											142911		15
33.8	41.37	18.5	4712	1.0	17.0	4500											102914		16
30.9	45.31	15	4179	1.1	15.5	4500											102913		17
25.3	55.33	11	3750	1.2	12.7	4500											102911		18

The dynamic efficiency is **0.94** for all ratios

- Motor Flanges Available Flange Motore Disponibili
- Supplied with Reduction Bushing Fornito con Bussola di Riduzione
- Available on Request without reduction bushing Disponibile a Richiesta senza Bussola di Riduzione
- Motor Flange Holes Position Posizione Fori Flangia Motore

EN Unit X113 is supplied without lubricant and equipped with a breather, level and drain plugs. User can add mineral oil keeping existing plugs. Should the user wish to fill it with synthetic oil, it is recommended to replace the existing plugs with a closed plug. See table 1 for lubrication and recommended quantity. In table 2 please see possible radial loads and axial loads on the gearbox.

I Il riduttore tipo X113 è fornito privo di lubrificazione con tappi di sfiato, livello e scarico olio. L'utente può immettere olio minerale mantenendo i tappi esistenti. Se immetterà olio sintetico, dovrà sostituire i tappi esistenti con altri tipo chiuso. Tab.1 per oli e quantità consigliati. Tab.2 carichi radiali e assiali applicabili al riduttore.

D Das Getriebe der Baugröße X113 wird ohne Schmiermittel geliefert. Es ist jedoch mit Einfüllschraube, Überdruckventil und Ablassschraube ausgerüstet. Das benötigte mineralische Öl kann über die Einfüllschraube eingefüllt werden. Sollte synthetisches Öl bevorzugt werden, so ist sind das eingebaute Überdruckventil durch eine geschlossenen Schraube zu ersetzen. In Tabelle 1 ist die Schmiermenge und das empfohlene Schmiermittel angegeben. In Tabelle 2 sind die zulässigen Radial - und Axialbelastungen des Getriebes aufgeführt.

F Le réducteur de type X113 est fourni sans lubrification et avec un bouchon de remplissage, de niveau et d'évacuation de l'huile. L'utilisateur peut y verser de l'huile minérale en conservant les bouchons existants. S'il y versera de l'huile synthétique, il devra substituer les bouchons existants avec d'autres bouchons de type fermé. Voir tableau 1 concernant les huiles et les quantités conseillées. Voir tableau 2 concernant les charges radiales et axiales applicables au réducteur

E El reductor tamaño X113 se suministra sin lubricante, provisto de tapones de respiración, nivel y descarga de aceite. El usuario puede utilizar aceite mineral, manteniendo los tapones existentes. Si prefiere utilizar aceite sintético deberá sustituir los tapones existentes por tapones ciegos. La prerreducción se suministra con tapones ciegos, lubricado de por vida con aceite sintético. Ver tabla 1, para cantidades y aceites recomendados. En la tabla 2, se encuentran las cargas radiales y axiales admitidas por el reductor.

Standard supplied	For these mounting position specify in the order or add oil					
13.50 LT	8.00 LT	15.50 LT	14.50 LT	22.00 LT	13.00 LT	Ask
SHELL Omala S2 GX 460				ENI Blasias 460		

For all details on lubrication and plugs check our website [tab. 1](#)
Per maggiori dettagli su lubrificazione e tappi olio vedi il nostro sito web

RADIAL AND AXIAL LOADS

Output shaft
Albero di uscita

$F_{eq} = F_R \cdot \frac{325.5}{X+255.5}$

n_2	FA	FR	n_2	FA	FR	n_2	FA	FR
300	2100	10500	140	3100	15500	70	4200	21000
250	2600	13000	120	3240	16200	40	5600	28000
200	3000	15000	85	3600	18000	15	8000	40000

Input shaft
Albero in entrata

n_1	FA	FR
1400	1120	5600
900	1220	6100
500	1300	6500

tab. 2

PX113C... Basic Gearbox
Riduttore base

Gearbox weight **170 kg**
peso riduttore

M. flanges	Kit code	øF	A
132B5	KC110.9.052	300	449.5
160B5	KC110.9.053	350	474.5
180B5	KC110.9.053_B	350	474.5
200B5	KC110.9.054	400	474.5
225B5	KC110.9.055	450	501.5

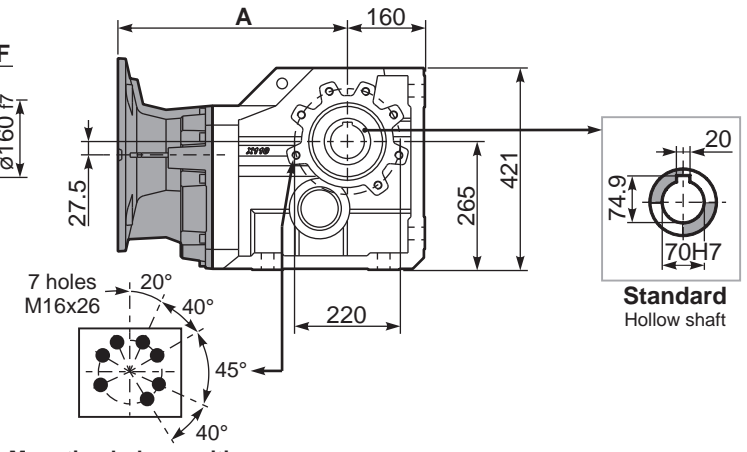
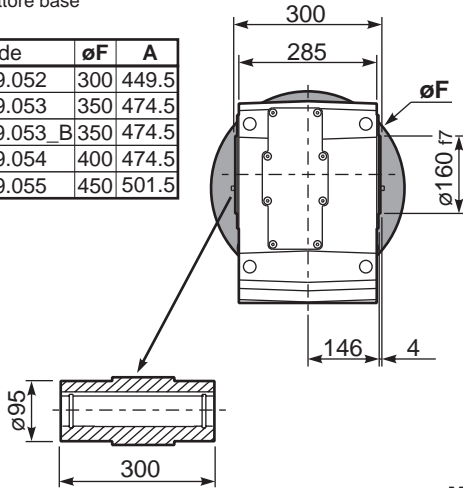
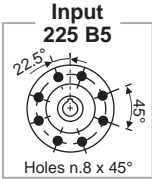

Mounting holes position
Posizione fori di montaggio

Standard
Hollow shaft

PX113...FB.. Feet
Piedini

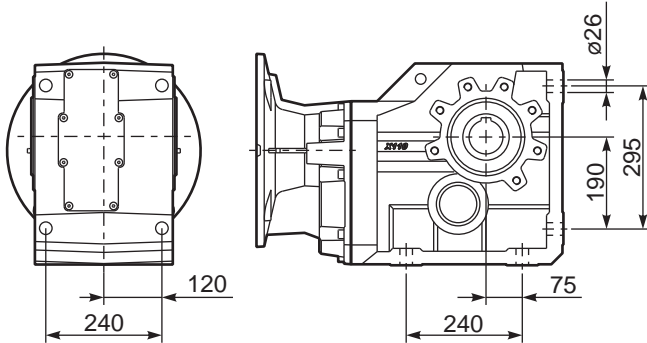

PX113...-F7.. Output flange
Flangia uscita

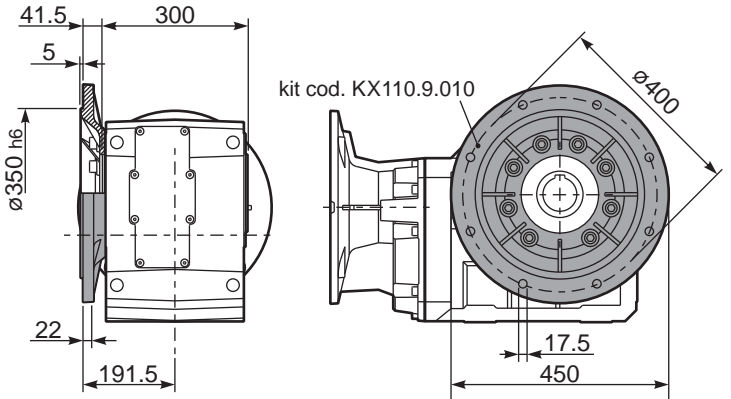

PX113...BR.. Reaction Arm
Braccio di reazione

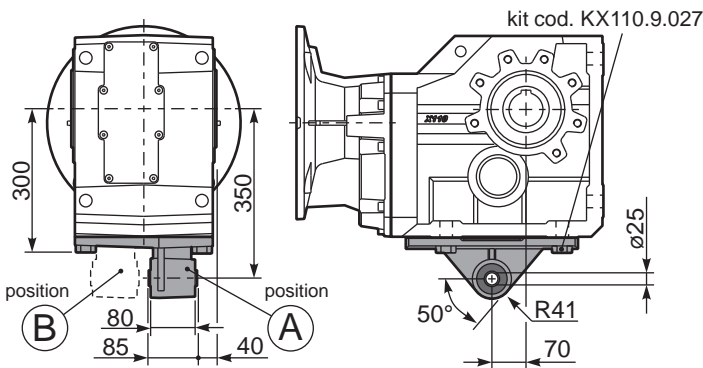

RX113... Input shaft
Albero in entrata

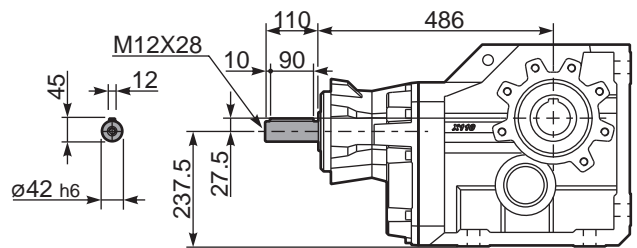

PX113A... Single shaft
Albero lento semplice

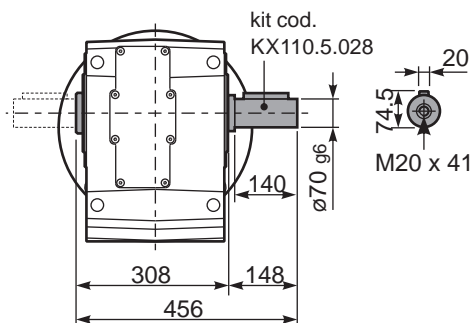

PX113B... Double shaft
Albero lento bisp.

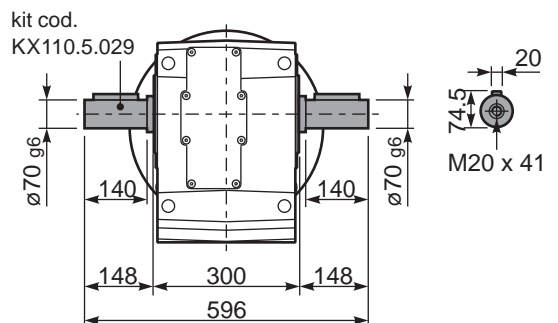



QUICK SELECTION / Selezione veloce

input speed (n₁) = 1400 min⁻¹

Output Speed n ₂ [min ⁻¹]	Ratio i	Motor power P _{1M} [kW]	Output torque M _{2M} [Nm]	Service factor f.s.	Nominal power P _{1R} [kW]	Nominal torque M _{2R} [Nm]	B5 motor flanges			B14 motor flanges		Output Shaft 	Ratios code
							-F	-G	-H	-U	-V		
							100 112	132	160	100 112	132		
28.8	48.57	15	4390	1.0	14.8	4500					30142911	01	
20.5	68.43	11	4545	1.0	10.7	4600					20142914	02	
18.7	74.95	11	4977	0.9	9.8	4600					20142913	03	
15.1	92.53	7.5	4216	1.1	7.9	4600					16142914	04	
13.8	101.33	7.5	4617	1.0	7.2	4600					16142913	05	
11.6	120.33	5.5	4051	1.1	6.1	4600					13142914	06	
11.3	123.75	5.5	4166	1.1	5.8	4500					16142911	07	
10.6	131.78	5.5	4436	1.0	5.6	4600					13142913	08	
9.5	147.28	5.5	4958	0.9	5.0	4600					11142914	09	
8.7	161.30	4	3972	1.2	4.5	4600					11142913	10	
7.1	196.98	3	3652	1.2	3.6	4500					11142911	11	
6.6	212.99	3	3949	1.2	3.4	4600					8142914	12	
6.0	233.26	3	4324	1.1	3.1	4600					8142913	13	
4.9	284.86	2.2	3889	1.2	2.5	4500					8142911	14	

The dynamic efficiency is **0.92** for all ratios

Motor Flanges Available
Flange Motore Disponibili

Supplied with Reduction Bushing
Fornito con Bussola di Riduzione

Available on Request without reduction bushing
Disponibile a Richiesta senza Bussola di Riduzione

Motor Flange Holes Position
Posizione Fori Flangia Motore

EN Unit X114 is supplied without lubricant and equipped with a breather, level and drain plugs. User can add mineral oil keeping existing plugs. Should the user wish to fill it with synthetic oil, it is recommended to replace the existing plugs with a closed plug. See table 1 for lubrication and recommended quantity. In table 2 please see possible radial loads and axial loads on the gearbox.

I Il riduttore tipo X114 è fornito privo di lubrificazione con tappi di sfiato, livello e scarico olio. L'utente può immettere olio minerale mantenendo i tappi esistenti. Se immetterà olio sintetico, dovrà sostituire i tappi esistenti con altri tipo chiuso. Tab.1 per oli e quantità consigliati. Tab.2 carichi radiali e assiali applicabili al riduttore.

D Das Getriebe der Baugröße X114 wird ohne Schmiermittel geliefert. Es ist jedoch mit Einfüllschraube, Überdruckventil und Ablassschraube ausgerüstet. Das benötigte mineralische Öl kann über die Einfüllschraube eingefüllt werden. Sollte synthetisches Öl bevorzugt werden, so ist das eingebaute Überdruckventil durch eine geschlossenen Schraube zu ersetzen. In Tabelle 1 ist die Schmiermenge und das empfohlene Schmiermittel angegeben. In Tabelle 2 sind die zulässigen Radial - und Axialbelastungen des Getriebes aufgeführt.

F Le réducteur de type X114 est fourni sans lubrification et avec un bouchon de remplissage, de niveau et d'évacuation de l'huile. L'utilisateur peut y verser de l'huile minérale en conservant les bouchons existants. S'il y versera de l'huile synthétique, il devra substituer les bouchons existants avec d'autres bouchons de type fermé. Voir tableau 1 concernant les huiles et les quantités conseillées. Voir tableau 2 concernant les charges radiales et axiales applicables au réducteur.

E El reductor tamaño X114 se suministra sin lubricante, provisto de tapones de respiración, nivel y descarga de aceite. El usuario puede utilizar aceite mineral, manteniendo los tapones existentes. Si prefiere utilizar aceite sintético deberá sustituir los tapones existentes por tapones ciegos. La prerreducción se suministra con tapones ciegos, lubricado de por vida con aceite sintético. Ver tabla 1, para cantidades y aceites recomendados. En la tabla 2, se encuentran las cargas radiales y axiales admitidas por el reductor.

Standard supplied	For these mounting position specify in the order or add oil					
	Per queste posizioni specificare in fase d'ordine o aggiungere olio					
B3	B6	B7	B8	V5	V6	V8
14.50 LT	8.50 LT	16.50 LT	16.00 LT	23.00 LT	14.50 LT	Ask
SHELL Omala S2 GX 460			ENI Blasia 460			

For all details on lubrication and plugs check our website **tab. 1**
Per maggiori dettagli su lubrificazione e tappi olio vedi il nostro sito web

RADIAL AND AXIAL LOADS

Output shaft
Albero di uscita

$$F_{eq} = F_R \cdot \frac{325.5}{X+255.5}$$

n ₂	FA	FR	n ₂	FA	FR	n ₂	FA	FR
300	2100	10500	140	3100	15500	70	4200	21000
250	2600	13000	120	3240	16200	40	5600	28000
200	3000	15000	85	3600	18000	15	8000	40000

Input shaft
Albero in entrata

n ₁	FA	FR
1400	700	3500
900	840	4200
500	900	4500

tab. 2

PX114C... Basic Gearbox
Riduttore base

Gearbox weight
peso riduttore **161 kg**

M. flanges	Kit code	øF	A
100/112B5	K023.4.043	250	442
132B5	KC51.4.043C	300	463.5
160B5	KC86.4.043	350	495.5
100/112B14	K085.4.047	160	442
132B14	KC51.4.041C	200	463.5

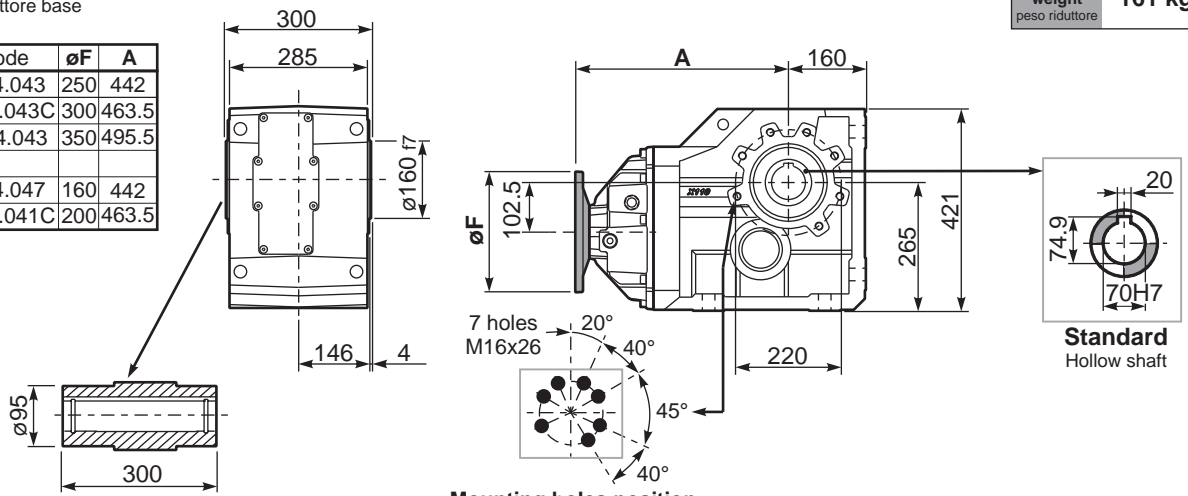

Mounting holes position
Posizione fori di montaggio

PX114...FB.. Feet
Piedini

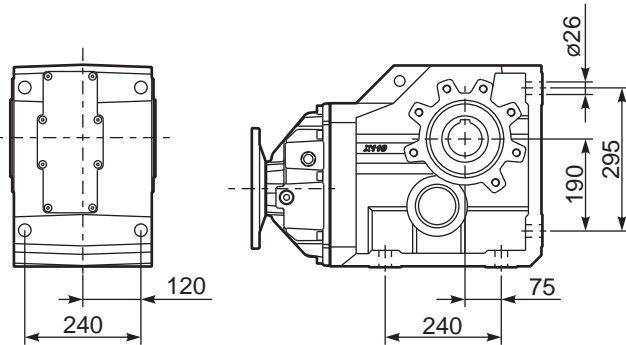

PX114...-F7.. Output flange
Flangia uscita

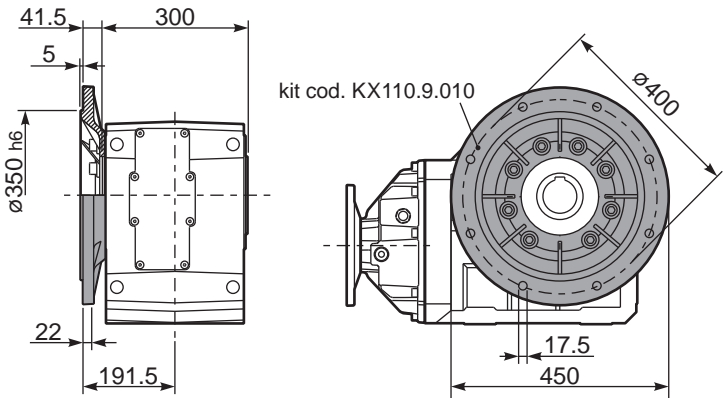

PX114...BR.. Reaction Arm
Braccio di reazione

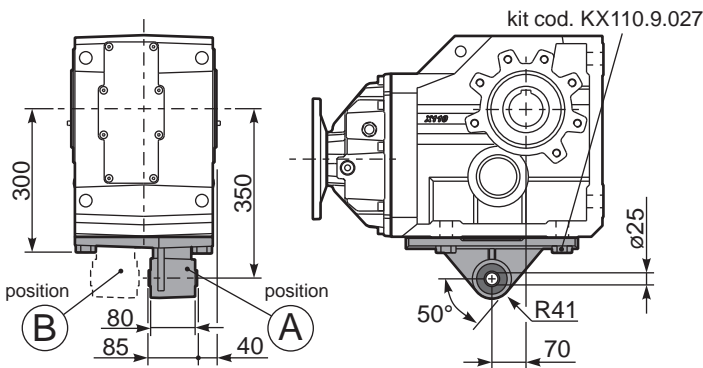

RX114... Input shaft
Albero in entrata

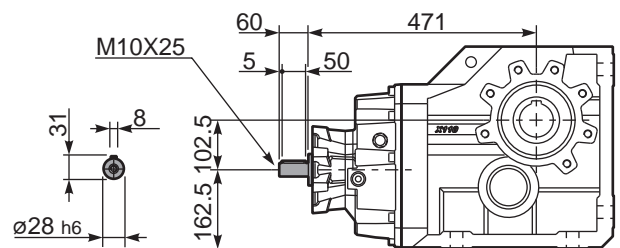

PX114A... Single shaft
Albero lento semplice

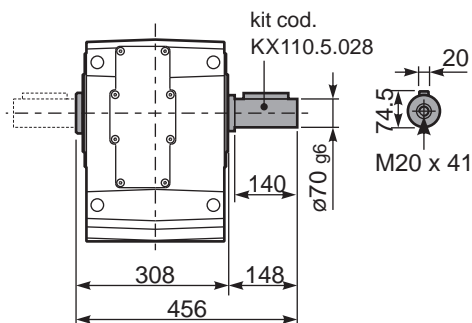

PX114B... Double shaft
Albero lento bisp.

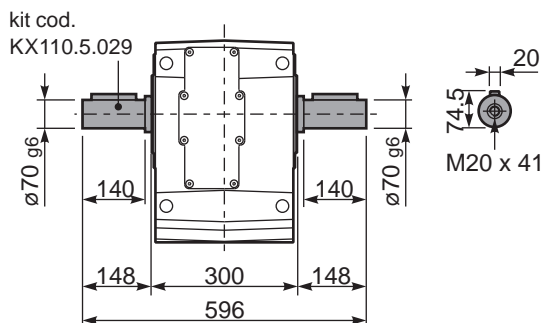

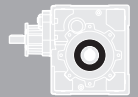

■ **QUICK SELECTION** / Selezione veloce

input speed (n_1) = 1400 min⁻¹

Output Speed n_2 [min ⁻¹]	Ratio i	Motor power P_{1M} [kW]	Output torque M_{2M} [Nm]	Service factor f.s.	Nominal power P_{1R} [kW]	Nominal torque M_{2R} [Nm]	Available B5 motor flanges					Available B14 motor flanges				Output Shaft 	Ratios code	
							-C	-D	-E	-F	-G	-R	-T	-U	-V			
							71	80	90	100 112	132	80	90	100 112	132			
176	7.94	7.5	369	1.0	7.5	380	B										302418	01
153	9.13	7.5	425	0.9	6.7	390	B										302416	02
131	10.66	5.5	366	1.1	6.0	410	B										302414	03
94	14.97	5.5	514	1.1	6.0	580	B										202418	04
81	17.21	5.5	591	1.0	5.4	600	B										202416	05
69	20.24	5.5	695	1.0	5.2	675	B										162418	06
60	23.27	4	585	1.2	4.5	675	B										162416	07
53	26.31	4	661	1.0	4.0	675	B										132418	08
46.3	30.25	4	760	0.9	3.5	675	B										132416	09
39.6	35.32	3	668	1.0	3.0	675	B										132414	10
37.8	37.03	3	701	1.0	2.8	675	B										112416	11
32.4	43.23	2.2	602	1.1	2.4	675	B										112414	12
30.1	46.58	2.2	649	1.0	2.3	675	B										82418	13
26.1	53.55	2.2	746	0.9	2.0	675	B										82416	14
22.4	62.52	1.5	600	1.1	1.7	675	B										82414	15
19.0	73.75	1.1	517	1.1	1.2	580	B										62416	16
16.3	86.09	1.1	604	1.1	1.2	675	B										62414	17

The dynamic efficiency is **0.94** for all ratios

A Motor Flanges Available
Flange Motore Disponibili

B Supplied with Reduction Bushing
Fornito con Bussola di Riduzione

B Available on Request without reduction bushing
Disponibile a Richiesta senza Bussola di Riduzione

C Motor Flange Holes Position
Posizione Fori Flangia Motore

EN Unit 113C is supplied with synthetic oil for lifetime lubrication, no maintenance is necessary. See table 1 for lubrication and recommended quantity. In table 2 please see possible radial loads and axial loads on the gearbox.

I Il riduttore 113C viene fornito completo di olio sintetico per la lubrificazione permanente e non necessita di alcuna manutenzione. Vedi tab.1 per oli e quantità consigliati. In tab.2 sono presenti i carichi radiali e assiali applicabili al riduttore.

D Das Getriebe 113C ist mit synthetischem Öl gefüllt und ist lebensdauergeschmiert. In Tabelle 1 ist die Schmiermenge und das empfohlene Schmiermittel angegeben. In Tabelle 2 sind die zulässigen Radial - und Axialbelastungen des Getriebes aufgeführt.

F Le réducteur 113C est fourni complet avec de l'huile synthétique pour la lubrification permanente et ne nécessite aucun entretien. Voir tableau 1 concernant les huiles et les quantités conseillées. Les charges radiales et axiales applicables au réducteur sont précisées dans le tableau 2.

E El reductor tamaño 113C se suministra, lubricado de por vida con aceite sintético y no requieren mantenimiento alguna. Ver tabla 1, para cantidades y aceites recomendados. En la tabla 2, se encuentran las cargas radiales y axiales admitidas por el reductor.

Standard supplied	For these mounting position specify in the order or add oil Per queste posizioni specificare in fase d'ordine o aggiungere olio					
B3	B6	B7	B8	V5	V6	V8
4.00 LT	2.60 LT	2.60 LT	2.60 LT	5.15 LT	2.20 LT	Ask
SHELL Omala S4 WE 320				ENI Telium VSF 320		

For all details on lubrication and plugs check our website **tab. 1**
Per maggiori dettagli su lubrificazione e tappi olio vedi il nostro sito web

RADIAL AND AXIAL LOADS

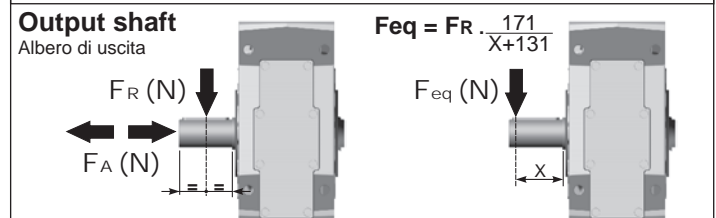

n_2	FA	FR	n_2	FA	FR	n_2	FA	FR
300	640	3200	140	860	4300	70	1080	5400
250	700	3500	120	900	4500	40	1300	6500
200	740	3700	85	1000	5000	15	1840	9200

On request reinforced bearings to increase loads.

A richiesta cuscinetti rinforzati per aumentare i carichi.

Input shaft

Albero in entrata

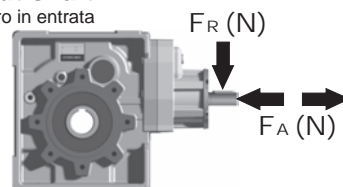

n_1	FA	FR
1400	400	2000
900	440	2200
500	440	2200

tab. 2

3D dimensions on the Web

P113CC... Basic Gearbox
Riduttore base

Gearbox weight **38.0 kg**
peso riduttore

M. flanges	Kit code	øF	A
71B5	K023.4.041	160	240.5
80/90B5	K023.4.042	200	242.5
100/112B5	K023.4.043	250	251.5
132B5	KC51.4.043	300	272.5
80B14	K085.4.046	120	242.5
90B14	K085.4.045	140	242.5
100/112B14	K085.4.047	160	251.5
132B14	KC51.4.041	200	272.5

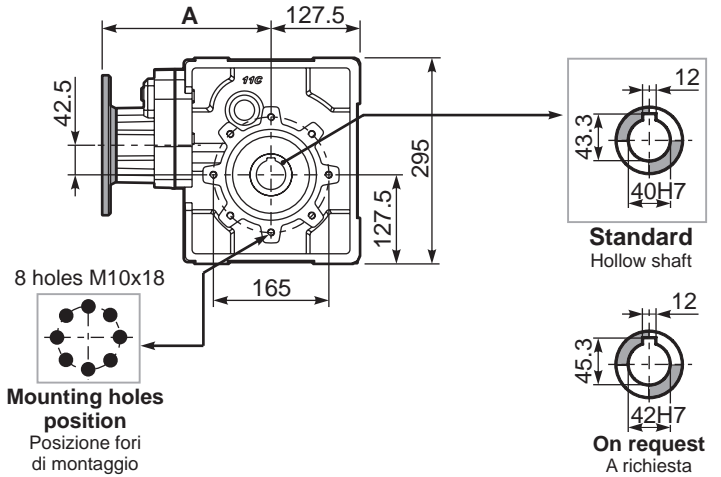
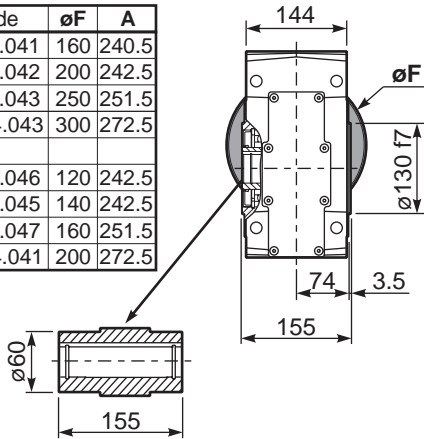

P113C...FB.. Feet
Piedini

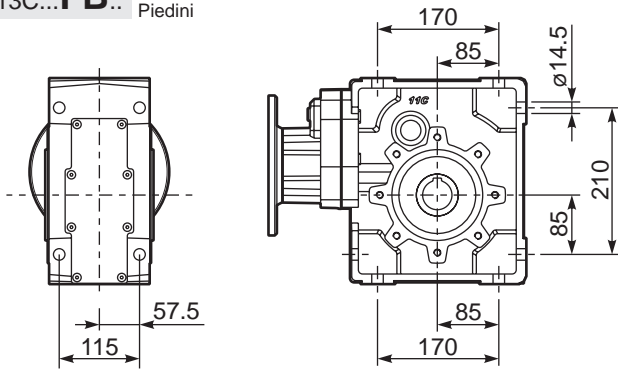

P113C...-FC.. Output flange
Flangia uscita

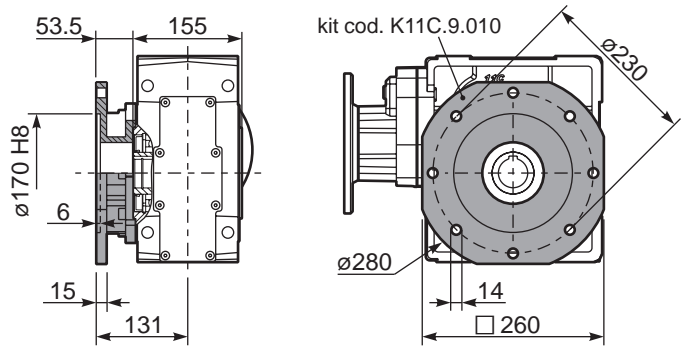

P113C...-FL.. Output flange
Flangia uscita

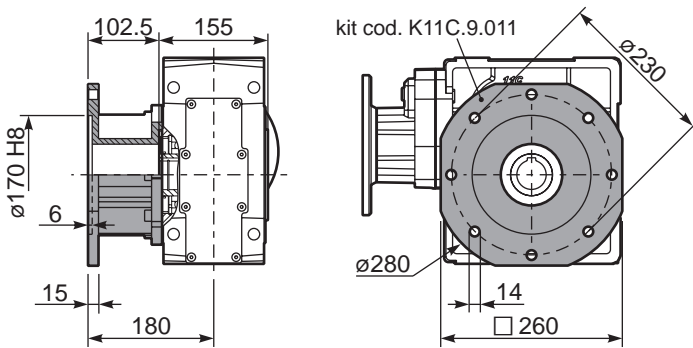

P113C...BR.. Reaction Arm
Braccio di reazione

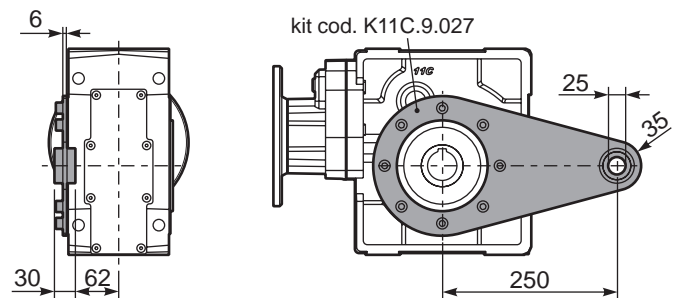

R113C... Input shaft
Albero in entrata

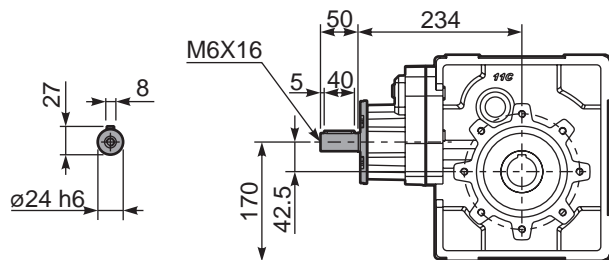

P113CA... Single shaft
Albero lento semplice

P113CB... Double shaft
Albero lento bisp.

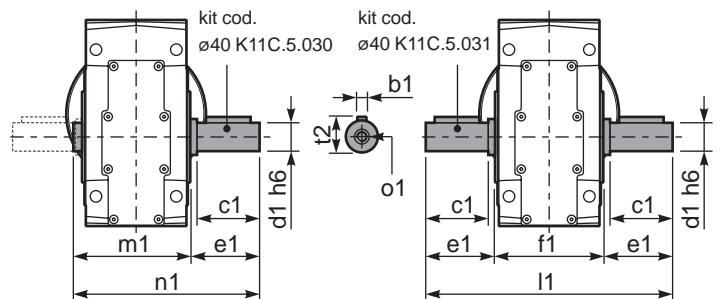

	b1	c1	d1	e1	f1	l1	m1	n1	t2	o1
ø40 Standard	12	80	40	84.5	155	324	164.5	249	43	M12
On request	-	-	-	-	-	-	-	-	-	-

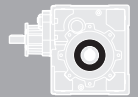

QUICK SELECTION / Selezione veloce

input speed (n₁) = 1400 min⁻¹

Output Speed n ₂ [min ⁻¹]	Ratio i	Motor power P _{1M} [kW]	Output torque M _{2M} [Nm]	Service factor f.s.	Nominal power P _{1R} [kW]	Nominal torque M _{2R} [Nm]	Available B5 motor flanges				Available B14 motor flanges			Output Shaft 	Ratios code
							-B	-C	-D	-E	-Q	-R	-T		
							63	71	80	90	71	80	90		
18.7	74.79	1.5	704	1.0	1.4	675	B				C	C		19132418	01
16.3	85.99	1.1	591	1.1	1.3	675	B				C	C		19132416	02
14.0	99.66	1.1	685	1.0	1.1	675	B				C	C		17132416	03
12.0	116.35	0.75	548	1.2	0.92	675	B				C	C		17132414	04
11.5	121.45	0.75	572	1.2	0.89	675	B				C	C		13132418	05
10.0	139.64	0.75	658	1.0	0.77	675	B				C	C		13132416	06
9.2	152.21	0.75	717	0.9	0.71	675	B				C	C		19082416	07
8.6	163.02	0.55	567	1.2	0.66	675	B				C	C		13132414	08
7.9	177.69	0.55	618	1.1	0.61	675	B				C	C		19082414	09
6.8	205.95	0.55	716	0.9	0.52	675	B				C	C		17082414	10
6.3	222.52	0.55	774	0.9	0.48	675	B				C	C		10132414	11
5.6	248.76	0.37	578	1.2	0.43	675	B				C	C		9132416	12
4.8	290.41	0.37	675	1.0	0.37	675	B				C	C		9132414	13
4.1	337.39	0.37	784	0.9	0.32	675	B				C	C		10082416	14
3.6	393.88	0.25	618	1.1	0.27	675	B				C	C		10082414	15
3.2	440.33	0.25	690	1.0	0.24	675	B				C	C		9082416	16
2.7	514.06	0.18	616	1.1	0.21	675	B				C	C		9082414	17
2.4	581.44	0.18	697	1.0	0.18	675	B				C	C		7082416	18
2.1	678.79	0.12	526	1.3	0.16	675	B				C	C		7082414	19

The dynamic efficiency is **0.92** for all ratios

A Motor Flanges Available
Flange Motore Disponibili

B Supplied with Reduction Bushing
Fornito con Bussola di Riduzione

B Available on Request without reduction bushing
Disponibile a Richiesta senza Bussola di Riduzione



C Motor Flange Holes Position
Posizione Fori Flangia Motore

EN Unit **114C** is supplied with synthetic oil for lifetime lubrication, no maintenance is necessary. See table 1 for lubrication and recommended quantity. In table 2 please see possible radial loads and axial loads on the gearbox.

I Il riduttore **114C** viene fornito completo di olio sintetico per la lubrificazione permanente e non necessita di alcuna manutenzione. Vedi tab.1 per oli e quantità consigliati. In tab.2 sono presenti i carichi radiali e assiali applicabili al riduttore.

D Das Getriebe **114C** ist mit synthetischem Öl gefüllt und ist lebensdauer geschmiert. In Tabelle 1 ist die Schmiermenge und das empfohlene Schmiermittel angegeben. In Tabelle 2 sind die zulässigen Radial - und Axialbelastungen des Getriebes aufgeführt.

F Le réducteur **114C** est fourni complet avec de l'huile synthétique pour la lubrification permanente et ne nécessite aucun entretien. Voir tableau 1 concernant les huiles et les quantités conseillées. Les charges radiales et axiales applicables au réducteur sont précisées dans le tableau 2.

E El reductor tamaño **114C** se suministra, lubricado de por vida con aceite sintético y no requieren mantenimiento alguna. Ver tabla 1, para cantidades y aceites recomendados. En la tabla 2, se encuentran las cargas radiales y axiales admitidas por el reductor.

Standard supplied	For these mounting position specify in the order or add oil Per queste posizioni specificare in fase d'ordine o aggiungere olio					
B3	B6	B7	B8	V5	V6	V8
4.10 LT	2.70 LT	2.70 LT	2.70 LT	5.30 LT	2.35 LT	Ask
SHELL Omala S4 WE 320				ENI Telium VSF 320		

For all details on lubrication and plugs check our website **tab. 1**
Per maggiori dettagli su lubrificazione e tappi olio vedi il nostro sito web

RADIAL AND AXIAL LOADS

Output shaft Albero di uscita			Feq = FR $\frac{171}{X+131}$		
n ₂	FA	FR	n ₂	FA	FR
300	640	3200	140	860	4300
250	700	3500	120	900	4500
200	740	3700	85	1000	5000
n ₂	FA	FR	n ₂	FA	FR
70	1080	5400	40	1300	6500
15	1840	9200			

On request reinforced bearings to increase loads.
A richiesta cuscinetti rinforzati per aumentare i carichi.

Input shaft Albero in entrata

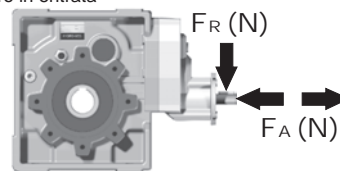

n ₁	FA	FR
1400	240	1200
900	280	1400
500	310	1700

tab. 2

3D dimensions on the Web

P114CC... Basic Gearbox
Riduttore base

Gearbox weight **38.0 kg**
peso riduttore

M. flanges	Kit code	øF	A
63B5	K063.4.041	140	252.5
71B5	K063.4.042	160	250.5
80/90B5	K063.4.043	200	252.5
71B14	K063.4.047	105	250.5
80B14	K063.4.046	120	252.5
90B14	K063.4.041	140	252.5

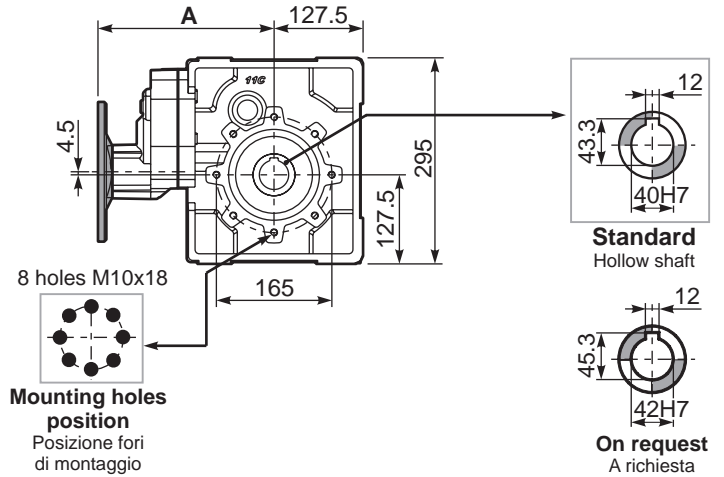
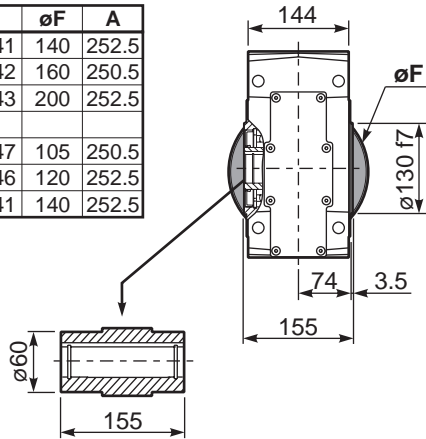

P114C...FB.. Feet
Piedini

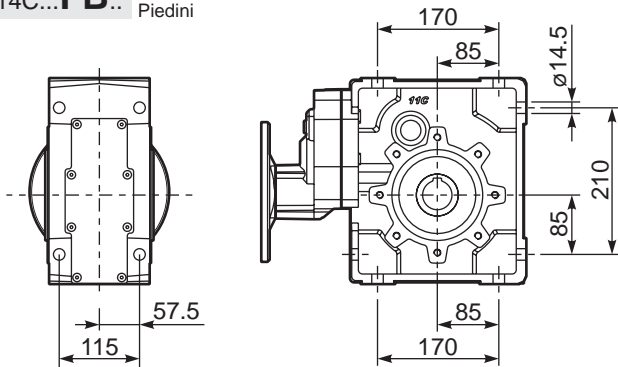

P114C...-FC.. Output flange
Flangia uscita

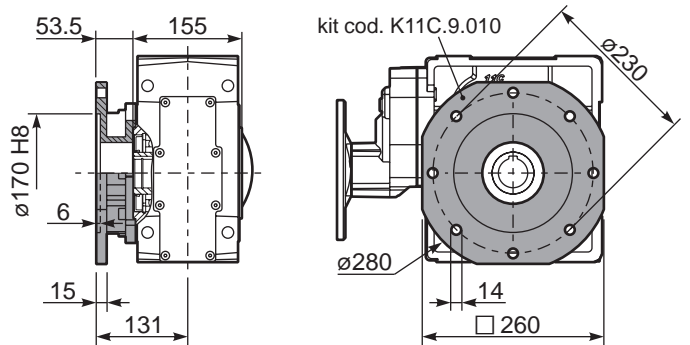

P114C...-FL.. Output flange
Flangia uscita

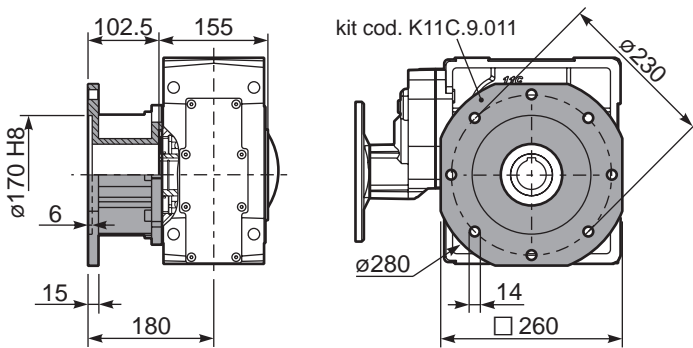

P114C...BR.. Reaction Arm
Braccio di reazione

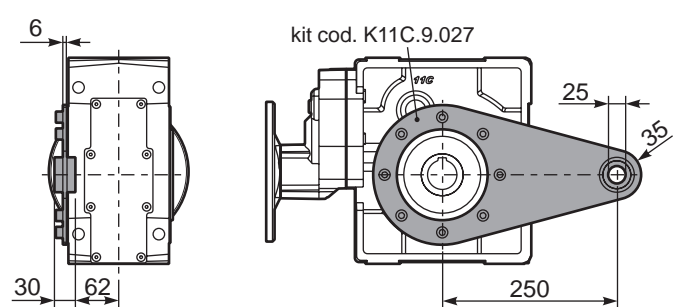

R114C... Input shaft
Albero in entrata

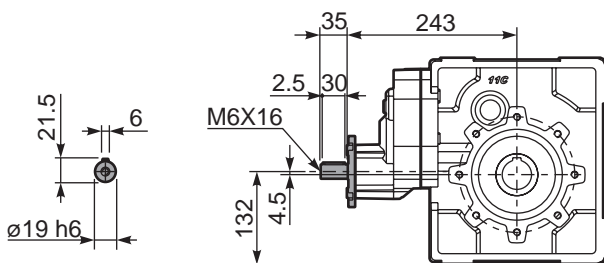

P114CA... Single shaft
Albero lento semplice

P114CB... Double shaft
Albero lento bisp.

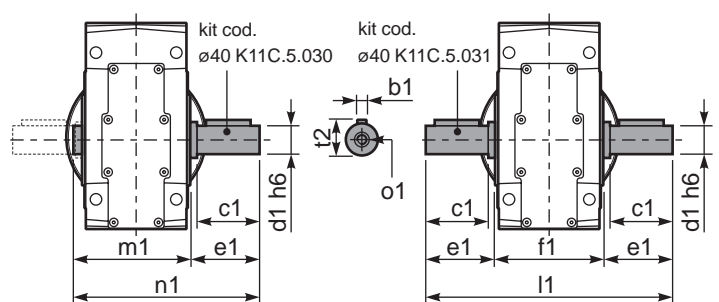

	b1	c1	d1	e1	f1	l1	m1	n1	t2	o1
ø40 Standard	12	80	40	84.5	155	324	164.5	249	43	M12
On request	-	-	-	-	-	-	-	-	-	-

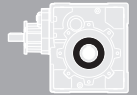

QUICK SELECTION / Selezione veloce

input speed (n_1) = 1400 min⁻¹

Output Speed n_2 [min ⁻¹]	Ratio i	Motor power P_{1M} [kW]	Output torque M_{2M} [Nm]	Service factor f.s.	Nominal power P_{1R} [kW]	Nominal torque M_{2R} [Nm]	Available B5 motor flanges					Available B14 motor flanges				Output Shaft 	Ratios code	
							-C	-D	-E	-F	-G	-R	-T	-U	-V			
							71	80	90	100 112	132	80	90	100 112	132			
145	9.69	9	560	1.3	12.2	755	B										302418	01
126	11.09	9	641	1.1	9.6	680	B										302416	02
108	12.90	9	746	1.1	9.6	790	B										302414	03
77	18.26	7.5	849	1.1	8.0	935	B										202418	04
67	20.91	7.5	972	1.0	7.5	1000	B										202416	05
58	24.32	5.5	835	1.2	6.4	1000	B										202414	06
49.5	28.27	5.5	971	1.0	5.5	1000	B										162416	07
42.6	32.88	4	826	1.2	4.7	1000	B										162414	08
38.1	36.76	4	924	1.1	4.2	1000	B										132416	09
32.7	42.76	3	809	1.2	3.6	1000	B										132414	10
31.1	45.00	3	851	1.2	3.5	1000	B										112416	11
26.8	52.33	3	990	1.0	3.0	1000	B										112414	12
24.6	56.82	2.2	791	1.1	2.3	850	B										82418	13
21.5	65.07	2.2	906	1.1	2.3	975	B										82416	14
18.5	75.68	2.2	1054	0.9	2.1	1000	B										82414	15
15.6	89.61	1.1	628	1.1	1.2	710	B										62416	16
13.4	104.22	1.1	731	1.1	1.2	820	B										62414	17

The dynamic efficiency is **0.94** for all ratios

Motor Flanges Available
Flange Motore Disponibili

B) Supplied with Reduction Bushing
Fornito con Bussola di Riduzione

B) Available on Request without reduction bushing
Disponibile a Richiesta senza Bussola di Riduzione

C) Motor Flange Holes Position
Posizione Fori Flangia Motore

EN Unit 133C is supplied without lubricant and equipped with a breather, level and drain plugs. User can add mineral oil keeping existing plugs. Should the user wish to fill it with synthetic oil, it is recommended to replace the existing plugs with a closed plug. See table 1 for lubrication and recommended quantity. In table 2 please see possible radial loads and axial loads on the gearbox.

I Il riduttore tipo 133C è fornito privo di lubrificazione con tappi di sfiato, livello e scarico olio. L'utente può immettere olio minerale mantenendo i tappi esistenti. Se immetterà olio sintetico, dovrà sostituire i tappi esistenti con altri tipo chiuso. Tab.1 per oli e quantità consigliati. Tab.2 carichi radiali e assiali applicabili al riduttore.

D Das Getriebe der Baugröße 133C wird ohne Schmiermittel geliefert. Es ist jedoch mit Einfüllschraube, Überdruckventil und Ablassschraube ausgerüstet. Das benötigte mineralische Öl kann über die Einfüllschraube eingefüllt werden. Sollte synthetisches Öl bevorzugt werden, so ist sind das eingebaute Überdruckventil durch eine geschlossenen Schraube zu ersetzen. In Tabelle 1 ist die Schmiermenge und das empfohlene Schmiermittel angegeben. In Tabelle 2 sind die zulässigen Radial - und Axialbelastungen des Getriebes aufgeführt.

F Le réducteur de type 133C est fourni sans lubrification et avec un bouchon de remplissage, de niveau et d'évacuation de l'huile. L'utilisateur peut verser de l'huile minérale en conservant les bouchons existants. S'il y versera de l'huile synthétique, il devra substituer les bouchons existants avec d'autres bouchons de type fermé. Voir tableau 1 concernant les huiles et les quantités conseillées. Voir tableau 2 concernant les charges radiales et axiales applicables au réducteur.

E El reductor tamaño 133C se suministra sin lubricante, provisto de tapones de respiración, nivel y descarga de aceite. El usuario puede utilizar aceite mineral, manteniendo los tapones existentes. Si prefiere utilizar aceite sintético deberá sustituir los tapones existentes por tapones ciegos. La prerreducción se suministra con tapones ciegos, lubricado de por vida con aceite sintético. Ver tabla 1, para cantidades y aceites recomendados. En la tabla 2, se encuentran las cargas radiales y axiales admitidas por el reductor.

B3	B6	B7	B8	V5	V6	V8
6.00 LT	4.30 LT	4.30 LT	3.30 LT	7.20 LT	3.10 LT	Ask
SHELL Omala S2 GX 460				ENI Blasias 460		

For all details on lubrication and plugs check our website [www.angletech.com](#) **tab. 1**
Per maggiori dettagli su lubrificazione e tappi olio vedi il nostro sito web

RADIAL AND AXIAL LOADS

Output shaft
Albero di uscita

$F_R(N)$ $F_A(N)$ $F_{eq} = F_R \frac{184.5}{X+144.5}$

n_2	F_A	F_R	n_2	F_A	F_R	n_2	F_A	F_R
300	800	4000	140	1120	5600	70	1400	7000
250	900	4500	120	1200	6000	40	1700	8500
200	960	4800	85	1300	6500	15	2400	12000

On request reinforced bearings to increase loads.

A richiesta cuscinetti rinforzati per aumentare i carichi.

Input shaft

Albero in entrata

n_1	F_A	F_R
1400	450	2250
900	500	2500
500	600	3000

tab. 2

P133CC... Basic gearbox
Riduttore base

Gearbox weight **53.5 kg**
peso riduttore

M. flanges	Kit code	øF	A
71B5	K023.4.041	160	251
80/90B5	K023.4.042	200	253
100/112B5	K023.4.043	250	262
132B5	KC51.4.043	300	283
80B14	K085.4.046	120	253
90B14	K085.4.045	140	253
100/112B14	K085.4.047	160	262
132B14	KC51.4.041	200	283

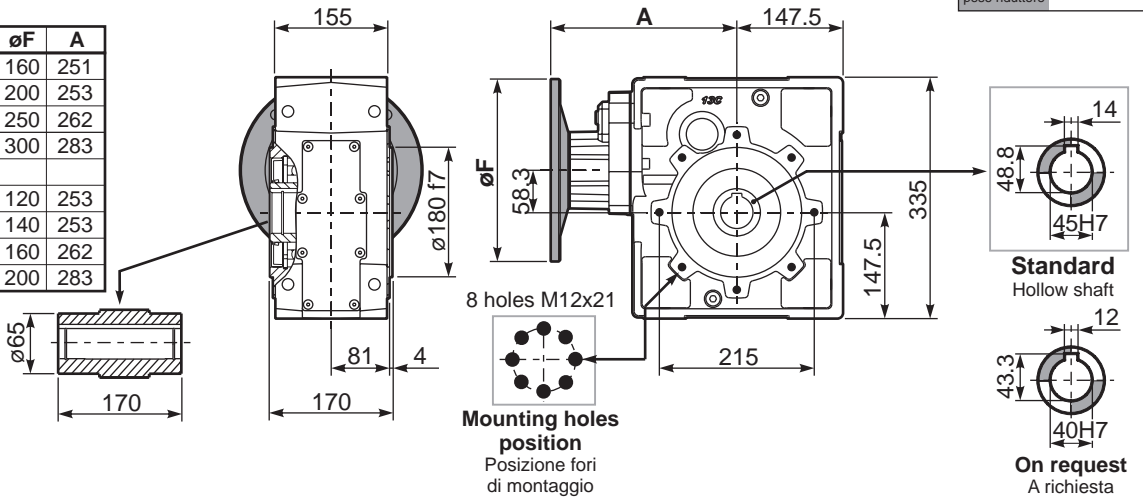

P133C...FB.. Feet
Piedini

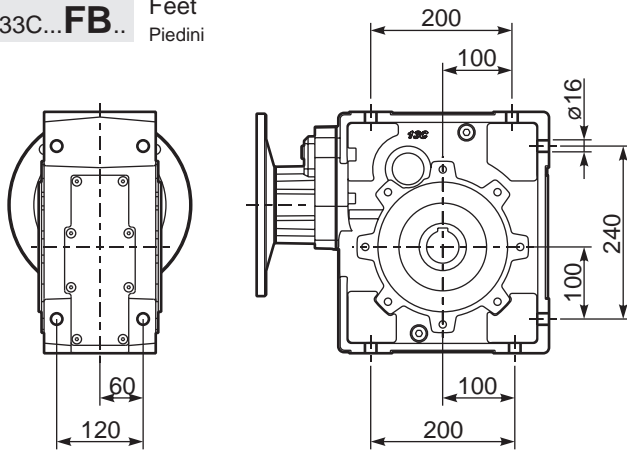

P133C...-FC.. Output flange
Flangia uscita

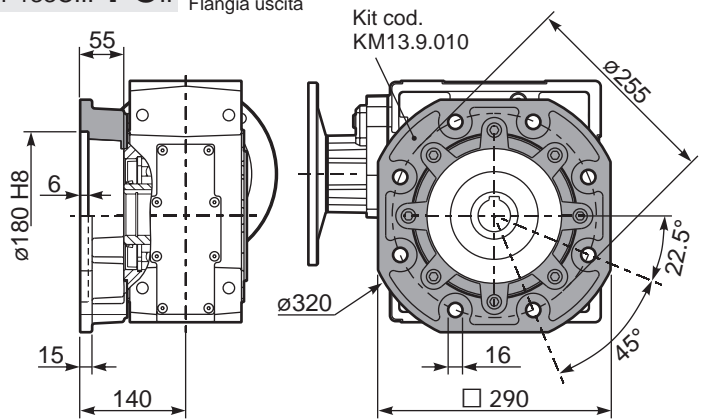

R133C... Input Shaft
Albero in entrata

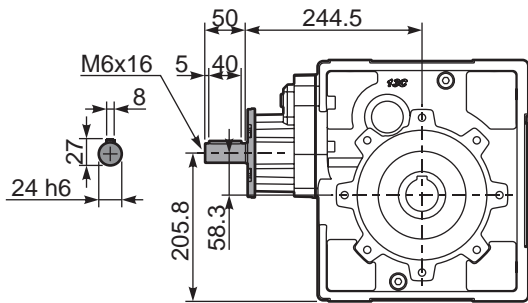

P133C...BR.. Reaction arm
Braccio di reazione

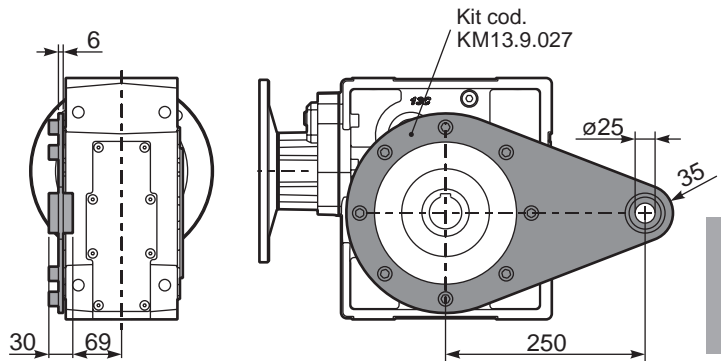

P133CA.. Single output Shaft
Albero lento semplice

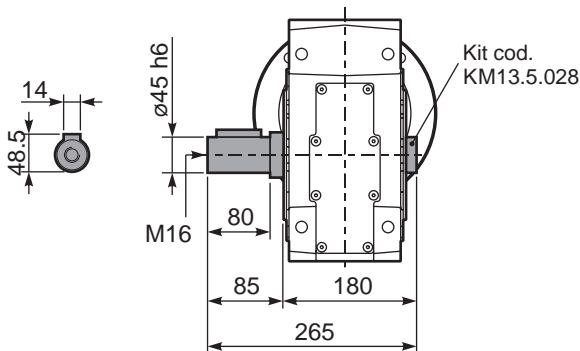

P133CB.. Double Input Shaft
Albero lento bisporgente

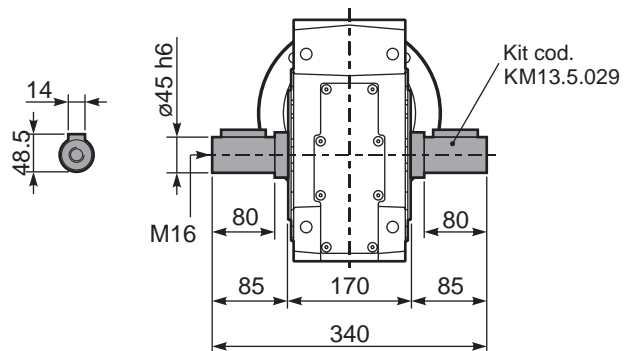

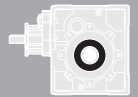

QUICK SELECTION / Selezione veloce

input speed (n_1) = 1400 min⁻¹

Output Speed n_2 [min ⁻¹]	Ratio i	Motor power P_{1M} [kW]	Output torque M_{2M} [Nm]	Service factor f.s.	Nominal power P_{1R} [kW]	Nominal torque M_{2R} [Nm]	Available B5 motor flanges				Available B14 motor flanges			Output Shaft 	Ratios code
							-B	-C	-D	-E	-Q	-R	-T		
							63	71	80	90	71	80	90		
15.3	91.23	1.5	858	1.2	1.7	1000	B				C	C		19132418	01
13.4	104.48	1.5	983	1.0	1.5	1000	B				C	C		19132416	02
11.6	121.10	1.5	1139	0.9	1.3	1000	B				C	C		17132416	03
9.9	140.84	1.1	968	1.0	1.1	1000	B				C	C		17132414	04
8.5	165.32	1.1	1136	0.9	0.96	1000	B				C	C		15132414	05
7.6	184.94	0.75	872	1.1	0.86	1000	B				C	C		19082416	06
7.1	197.34	0.75	930	1.1	0.81	1000	B				C	C		13132414	07
6.5	215.10	0.75	1014	1.0	0.74	1000	B				C	C		19082414	08
6.0	231.60	0.55	805	1.2	0.69	1000	B				C	C		10132416	09
5.6	249.31	0.55	867	1.2	0.64	1000	B				C	C		17082414	10
5.2	269.37	0.55	937	1.1	0.59	1000	B				C	C		10132414	11
4.8	292.64	0.55	1018	1.0	0.54	1000	B				C	C		15082414	12
4.6	302.26	0.55	1051	1.0	0.53	1000	B				C	C		9132416	13
4.0	349.30	0.37	812	1.2	0.46	1000	B				C	C		13082414	14
3.5	399.12	0.37	928	1.1	0.40	1000	B				C	C		7132416	15
2.9	476.80	0.37	1108	0.9	0.33	1000	B				C	C		10082414	16
2.2	622.28	0.25	976	1.0	0.26	1000	B				C	C		9082414	17
1.7	821.70	0.18	985	1.0	0.19	1000	B				C	C		7082414	18

The dynamic efficiency is **0.92** for all ratios

Motor Flanges Available
Flange Motore Disponibili

Supplied with Reduction Bushing
Fornito con Bussola di Riduzione

Available on Request without reduction bushing
Disponibile a Richiesta senza Bussola di Riduzione

Motor Flange Holes Position
Posizione Fori Flangia Motore

EN Unit **134C** is supplied without lubricant and equipped with a breather, level and drain plugs. User can add mineral oil keeping existing plugs. Should the user wish to fill it with synthetic oil, it is recommended to replace the existing plugs with a closed plug.
See table 1 for lubrication and recommended quantity.
In table 2 please see possible radial loads and axial loads on the gearbox.

B3	B6	B7	B8	V5	V6	V8
6.10 LT	4.40 LT	4.40 LT	3.40 LT	7.50 LT	3.20 LT	Ask
SHELL Omala S2 GX 460				ENI Blasia 460		

For all details on lubrication and plugs check our website **tab. 1**
Per maggiori dettagli su lubrificazione e tappi olio vedi il nostro sito web

I Il riduttore tipo **134C** è fornito privo di lubrificazione con tappi di sfiato, livello e scarico olio. L'utente può immettere olio minerale mantenendo i tappi esistenti. Se immetterà olio sintetico, dovrà sostituire i tappi esistenti con altri tipo chiuso.
Tab.1 per oli e quantità consigliati.
Tab.2 carichi radiali e assiali applicabili al riduttore.

D Das Getriebe der Baugröße **134C** wird ohne Schmiermittel geliefert. Es ist jedoch mit Einfüllschraube, Überdruckventil und Ablassschraube ausgerüstet. Das benötigte mineralische Öl kann über die Einfüllschraube eingefüllt werden. Sollte synthetisches Öl bevorzugt werden, so ist sind das eingebaute Überdruckventil durch eine geschlossenen Schraube zu ersetzen.
In Tabelle 1 ist die Schmiermenge und das empfohlene Schmiermittel angegeben.
In Tabelle 2 sind die zulässigen Radial - und Axialbelastungen des Getriebes aufgeführt.

F Le réducteur de type **134C** est fourni sans lubrification et avec un bouchon de remplissage, de niveau et d'évacuation de l'huile. L'utilisateur peut verser de l'huile minérale en conservant les bouchons existants.
S'il y versera de l'huile synthétique, il devra substituer les bouchons existants avec d'autres bouchons de type fermé.
Voir tableau 1 concernant les huiles et les quantités conseillées.
Voir tableau 2 concernant les charges radiales et axiales applicables au réducteur

E El reductor tamaño **134C** se suministra sin lubricante, provisto de tapones de respiración, nivel y descarga de aceite. El usuario puede utilizar aceite mineral, manteniendo los tapones existentes. Si prefiere utilizar aceite sintético deberá sustituir los tapones existentes por tapones ciegos. La prerreducción se suministra con tapones ciegos, lubricado de por vida con aceite sintético.
Ver tabla 1, para cantidades y aceites recomendados. En la tabla 2, se encuentran las cargas radiales y axiales admitidas por el reductor.

RADIAL AND AXIAL LOADS

Output shaft
Albero di uscita

$F_R(N)$

$F_{eq}(N)$ $F_{eq} = FR \cdot \frac{184.5}{X+144.5}$

n_2	FA	FR	n_2	FA	FR	n_2	FA	FR
300	800	4000	140	1120	5600	70	1400	7000
250	900	4500	120	1200	6000	40	1700	8500
200	960	4800	85	1300	6500	15	2400	12000

On request reinforced bearings to increase loads.
A richiesta cuscinetti rinforzati per aumentare i carichi.

Input shaft
Albero in entrata

$F_R(N)$ $F_A(N)$

n_1	FA	FR
1400	400	2000
900	440	2200
500	440	2200

tab. 2

P134CC... Basic gearbox
Riduttore base

Gearbox weight **53.5 kg**
peso riduttore

M. flanges	Kit code	øF	A
63B5	K063.4.041	140	263
71B5	K063.4.042	160	261
80/90B5	K063.4.043	200	263
71B14	K063.4.047	105	261
80B14	K063.4.046	120	263
90B14	K063.4.041	140	263

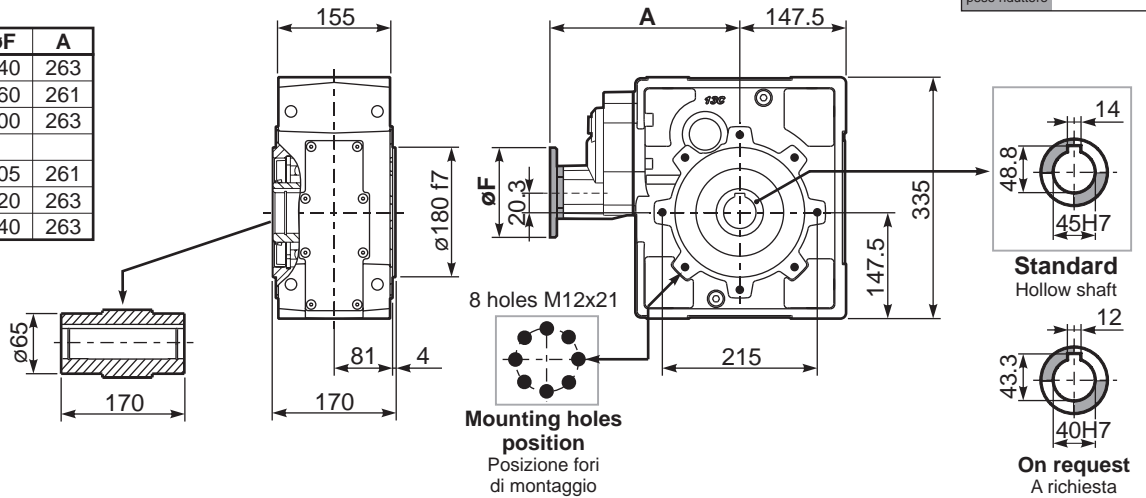

P134C...FB... Feet
Piedini

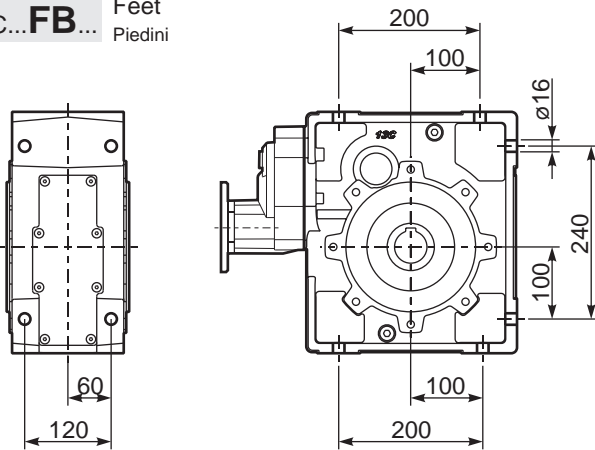

P134C...-FC... Output flange
Flangia uscita

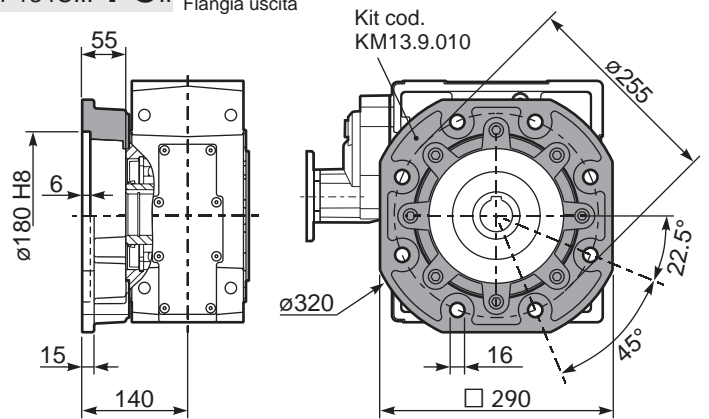

R134C... Input Shaft
Albero in entrata

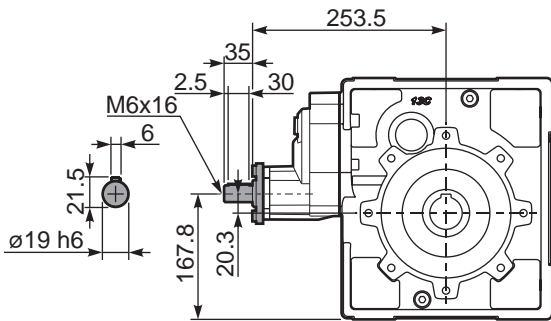

P134C...BR... Reaction arm
Braccio di reazione

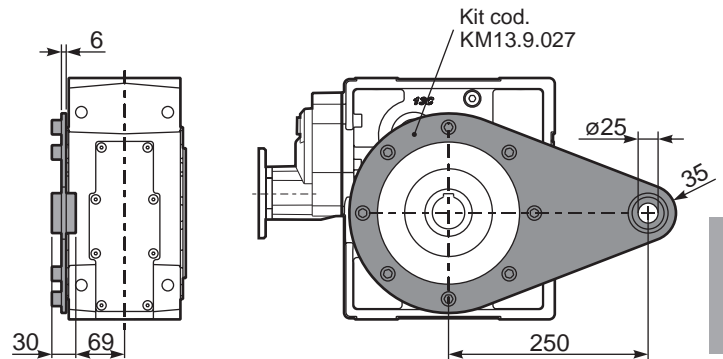

P134CA.. Single output Shaft
Albero lento semplice

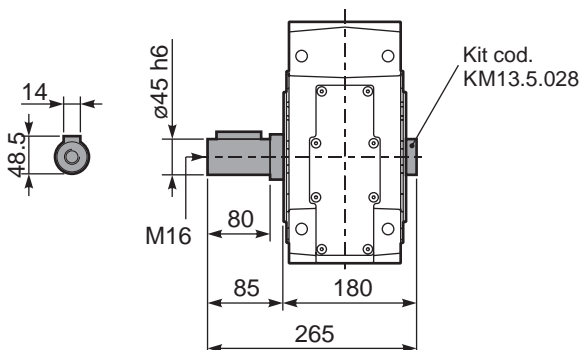

P134CB.. Double Input Shaft
Albero lento bisporgente

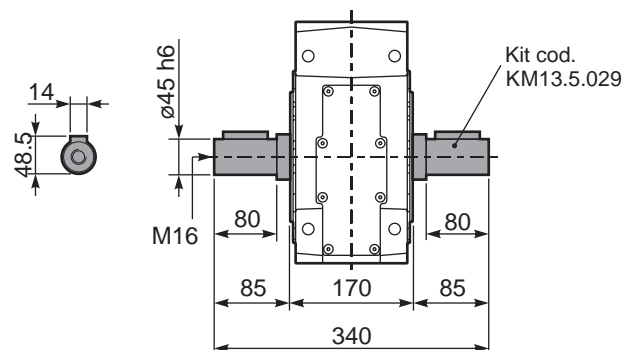

Aluminum IEC motors

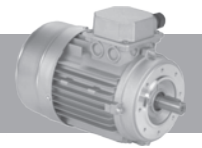

- 1) 230/400V - 50Hz three-phase asynchronous induction motor
- 2) Class F insulation
- 3) S1 duty
- 4) IP 55 protection
- 5) Not painted
- 6) Hard plastic sleeve to protect output shaft during the transportation

- 1) 230/400V - 50Hz motore trifase asincrono
- 2) Isolamento Classe F
- 3) S1 servizio continuo
- 4) Protezione IP 55
- 5) Non verniciato
- 6) Manicotto di protezione per l'albero motore

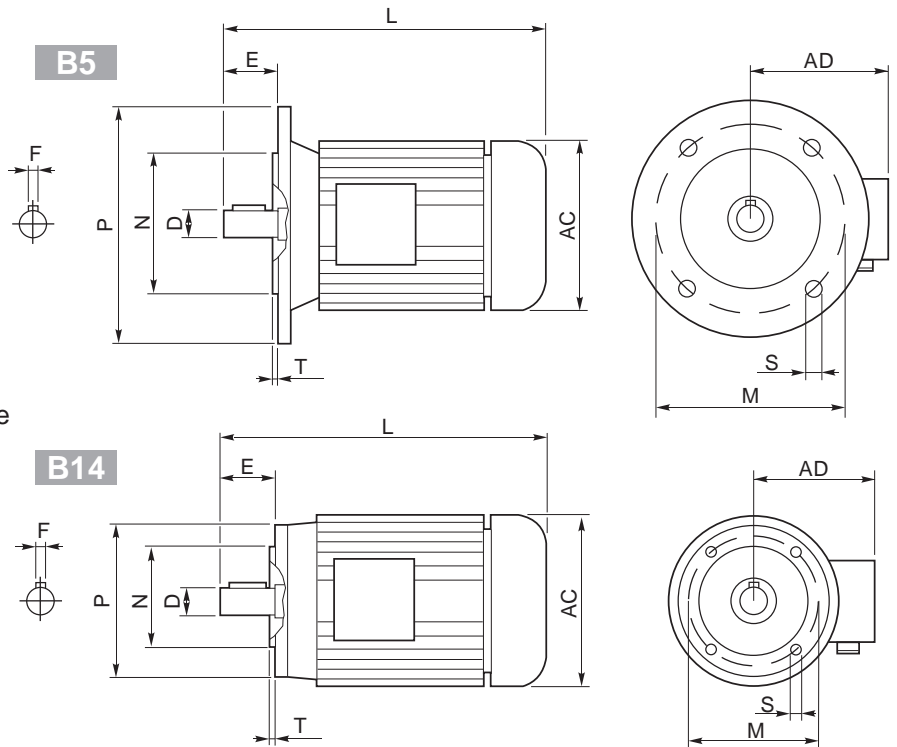

Outside dimensions and weight may be different according to manufacturers.
Le dimensioni esterne e il peso sono indicative, possono variare tra i vari costruttori.

	2 poli / poles			4 poli / poles			6 poli / poles			B5-B14						B5					B14					Kg
	kW	Nm	A (400V)	kW	Nm	A (400V)	kW	Nm	A (400V)	D	F	E	L	AC	AD	N	M	P	S	T	N	M	P	S	T	
56 A	0.09	0.32	0.38	0.06	0.44	0.27	—	—	—	9	3	20	199	108	96	80	100	120	7	2.5	50	65	80	M5	2.5	2.7
56 B	0.12	0.42	0.46	0.09	0.67	0.37	—	—	—	9	3	20	199	108	96	80	100	120	7	2.5	50	65	80	M5	2.5	2.9
63 A	0.18	0.63	0.60	0.12	0.84	0.50	0.09	0.99	0.57	11	4	23	208	120	99	95	115	140	9.5	3	60	75	90	M5	2.5	3.8
63 B	0.25	0.87	0.76	0.18	1.30	0.69	0.12	1.32	0.74	11	4	23	208	120	99	95	115	140	9.5	3	60	75	90	M5	2.5	4.2
71 A	0.37	1.30	1.00	0.25	1.70	0.91	0.18	1.90	0.80	14	5	30	-	130	104	110	130	160	9.5	3.5	70	85	105	M6	2.5	5.9
71 B	0.55	1.90	1.54	0.37	2.52	1.14	0.25	2.72	1.10	14	5	30	255	141	107	110	130	160	9.5	3.5	70	85	105	M6	2.5	6.5
80 A	0.75	2.60	1.85	0.55	3.77	1.51	0.37	3.84	1.18	19	6	40	296	159	127	130	165	200	11.5	3.5	80	100	120	M6	3	8.5
80 B	1.1	3.90	2.64	0.75	5.11	2.57	0.55	5.84	1.80	19	6	40	296	159	127	130	165	200	11.5	3.5	80	100	120	M6	3	10
90 S	1.5	5.00	3.31	1.1	7.45	2.78	0.75	7.92	2.32	24	8	50	-	170	135	130	165	200	11.5	3.5	95	115	140	M8	3	12.5
90 L	2.2	7.50	4.46	1.5	10.2	3.61	1.1	11.6	3.45	24	8	50	330	170	135	130	165	200	11.5	3.5	95	115	140	M8	3	15
100 LA	3.0	10.0	6.28	2.2	14.8	5.07	1.5	15.4	3.88	28	8	60	-	190	148	180	215	250	13	4	110	130	160	M8	3.5	20
100 LB	—	—	—	3.0	20.1	6.66	—	—	—	28	8	60	-	190	148	180	215	250	13	4	110	130	160	M8	3.5	22
112 M	4.0	13.4	8.10	4.0	26.7	8.55	2.2	22.6	5.30	28	8	60	381	210	164	180	215	250	13	4	110	130	160	M8	3.5	35
132 S	5.5	18.3	11.2	5.5	36.5	11.4	3.0	30.2	7.20	38	10	80	455	244	180	230	265	300	14	4	130	165	200	M10	4	41
	7.5	24.9	15.3																							51
132 M	—	—	—	7.5	49.4	15.0	4.0	40.0	9.13	38	10	80	500	244	180	230	265	300	14	4	130	165	200	M10	4	51
	9	61.4	18.5	51																						
160 M	—	—	—	11	72	21.5	—	—	—	42	12	110	613	335	246	250	300	350	18	5	—	—	—	—	—	79.2
160 L	—	—	—	15	98	29	—	—	—	42	12	110	657	335	246	250	300	350	18	5	—	—	—	—	—	97.5
180 M	—	—	—	18.5	121	35.5	—	—	—	48	14	110	712	366	266	250	300	350	19	5	—	—	—	—	—	170
180 L	—	—	—	22	144	42	—	—	—	48	14	110	712	366	266	250	300	350	19	5	—	—	—	—	—	170
200 L	—	—	—	30	196	53	—	—	—	55	16	110	780	405	341	300	350	400	19	5	—	—	—	—	—	240
225 S	—	—	—	37	240	69	—	—	—	60	18	140	888	463	360	350	400	450	19	5	—	—	—	—	—	305
225 M	—	—	—	45	292	84	—	—	—	60	18	140	888	463	360	350	400	450	19	5	—	—	—	—	—	310

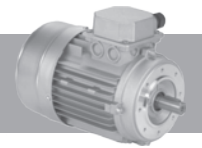

Protection

Standard IP55
Please specify on purchase orders if you need a higher IP protection class.

Grado di protezione

IP55 Standard
Specificare in sede di ordinazione per IP superiore.

Schutzart

IP55 Standard.
Höheren IP Grad bitte im Auftrag angeben.

Degré de protection

IP55 standard.
Au moment de la commande, spécifiez si vous souhaitez IP supérieur.

Grado de protección
IP55 standard.
Especificar en el pedido cuando necesiten protección IP superior.

Insulation

Standard CI.F
To be specified upon placing the order if different insulation is required.

Isolamento

CI.F Standard
Specificare in sede di ordinazione classe di isolamento diversa.

Isolierung

CI.F Standard.
Davon abweichende Isolierungsklasse im Auftrag angeben.

Isolement

CI.F Standard.
Au moment de la commande, spécifiez si vous souhaitez une classe d'isolement différente.

Aislamiento

CI.F standard.
Especificar al efectuar el pedido la clase diferente de aislamiento.

Insulation / Isolamento Isolierung /Aislamiento		E	B	F	H
Max. temp.	C°	120°	130°	155°	175°
	F*	248°	266°	311°	347°

Connections

Collegamenti

Verbindungselemente

Branchements

Conexiones

Threephase asynchronous single polarity
Asincrono trifase singola polarità
Asynchronmotor 3-ph eine Drehzahl
Moteur triphasé à une vitesse
Asincrono trifasico de una velocidad

Threephase asynchronous double polarity
Asincrono trifase doppia polarità
Asynchronmotor 3-ph doppelte Drehzahl
Moteur triphasé à deux vitesses
Asincrono trifasico de dos velocidades

Single phase asynchronous
Asincrono monofase
Einphasen-Asynchronmotor
Moteur monophasé
Asincrono monofasico

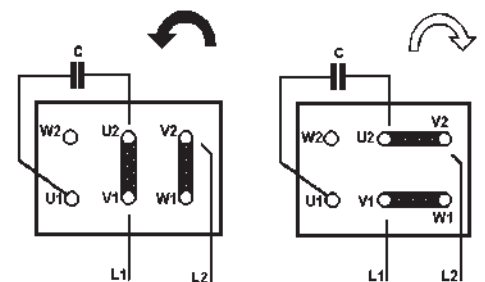
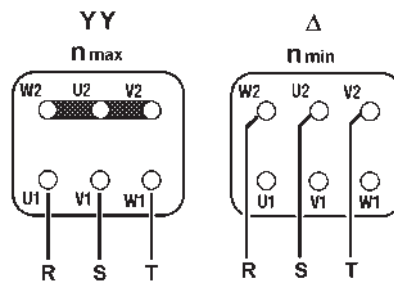
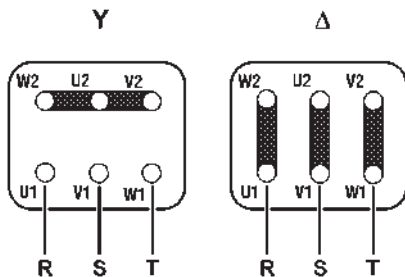

Quotations:

Unless differently agreed, the validity of all quotations is 2 months. The quotations are provided according to the RFQ (request for quotation) which shall contain the complete and detailed specification of the Product, the correctness of which is fully under responsibility of RFQ applicant.

Orders:

Only official orders issued on the Customer's letter-head are accepted. The Order Confirmation (OC) is issued within 2 working days from the order receipt unless the Products configuration issues arise. The OC shall be confirmed in writing within 2 working days from the OC date and in all its parts the product code and description, quantities and price, other specific information, if any. The OC is considered confirmed by tacit approval in case no written confirmation is provided by the Customer.

Production time:

An average production time for the standard Products is 3-4 weeks and 2-3 weeks for kits from the OC confirmation date and/or payment receipt in case of advanced payment term. For some configurations of the standard Products the production time can be different and shall be advised in the quotation and/or in any case in OC. In the period of Christmas holidays and August holidays the days of company closure are excluded from the abovementioned production term.

Delivery terms:

FCA Sovizzo, Italy (Incoterms 2016)

Packaging:

The products are packed in wooden boxes as a standard packaging. Europallets can be also used on request. The prices and details of the packaging are indicated in the apposite section of the Price List. Payment terms: the payment should be performed in terms indicated in the invoice and by wire transfer. Prices: the prices are indicated in the invoice and intended ex-works, unless differently specified, and do not include any kind of taxes, shipment or other type of costs.

Standard Products orders cancellation:

Modification or cancellation of the orders is accepted only if notified to Hydro-Mec S.p.A. in writing and not later than 3 days from the Order Confirmation and in any case before the production of the ordered Products is launched.

Special execution of customized products:

The Products that are not included in the catalogue or configurations of the products that can not be realized using catalogue, options and accessories brochure and/or online configurator (www.cleangeartech.com) are considered Customized Products.

(a) Hydro-Mec S.p.A. is entitled to examine feasibility of Special Execution of Customized Products and define the minimum quantity, production time and eventually other special sales and production conditions issuing thereafter a Special Execution Quotation that shall be confirmed by the Customer in writing.

(b) Once the Quotation is confirmed, Hydro-Mec S.p.A. shall realize a Special Execution (SE) data sheet with its unique code for each Customized product. The SE data sheet shall be confirmed in full and in writing by The Customer.

(c) The production time of SE is definitely settled by Hydro-Mec S.p.A. and notified to the Customer after the SE data sheet confirmation. As a rule, the production time for SE of Customized products is longer than standard.

(d) The orders of Special Execution of Customized products can not be cancelled unless special written agreement is made before the production of SE is launched.

WARRANTY Conditions:

(a) Warranty period is 12 months form the shipment date.

(b) Warranty period could be extended to 18 months prior written agreement of the parties and in any case excluding wearable parts.

(c) Warranty covers only manufacturing defects. Wearable parts (for example, oil seals or lubricants leakages caused by normal wear) and failures due to the wrong assembling by the Customer are not covered by warranty.

(d) This warranty is also void in any case in which the products have been misused, used in improper environment conditions, configurated beyond design limits indicated in the catalogue (especially service factor, loads and type of motors) or damaged, even accidentally or whenever installation instructions have not been strictly followed and in case of any natural disasters, in case of negligence of the Customer and the end user.

(e) The Customer is fully responsible to assure the compatibility of applications and correct mechanical couplings and electrical connections with the specifications of the Products according to Hydro-Mec S.p.A. catalogues and technical documentation

(f) The liability of Hydro-Mec S.p.A. is strictly limited to the above-stated obligations and it is therefore clearly agreed that Hydro-Mec S.p.A. take on no responsibility for any damage to persons and/or property deriving from accidents of any nature that may occur during use of the Products, whether the warranty is confirmed or otherwise, also in cases of the choice of the Product configuration being recommended by Hydro-Mec S.p.A.

WARRANTY Procedure:

(a) The Customer shall fill in the COMPLAINT FORM and forward it to Hydro-Mec S.p.A. along with other relevant information.

(b) Hydro-Mec S.p.A. examines the COMPLAINT FORM and confirms or declines the warranty.

(c) Hydro-Mec S.p.A. has the right to ask the Customer to send the malfunctioning product to Hydro-Mec S.p.A. for further examination. In case the warranty is not confirmed the Product will be shipped back to the Customer at the Customer expense. If the warranty is confirmed, Hydro-Mec S.p.A. shall compensate the shipment costs to the Customer within the limits of the best shipment quotation.

(d) In case the warranty is confirmed the Products shall be substituted at Hydro-Mec S.p.A. expense using ordinary shipment procedure. The express shipment can be used prior the agreement of the parties.

(e) In case the Product can not be substituted Hydro-Mec S.p.A. shall reimburse the value of the Product by issuing of Credit Note or in any other way agreed by the Parties.

WARNING (Please Read Carefully):

The following WARNING and CAUTION information is supplied to you for your protection and to provide you with many years of trouble free and safe operation of your product. Read ALL instructions prior to operating reducer. Injury to personnel or reducer failure may be caused by improper installation, maintenance or operation.

- (a) Written authorization is required to operate or use reducers in man lift or people moving devices.
- (b) Check to make sure that certain applications do not exceed the allowable load capacities published in the current catalog.
- (c) Buyer shall be solely responsible for determining the adequacy of the product for any and all uses to which Buyer shall apply the product. The application by Buyer shall not be subject to any implied warranty of fitness for a particular purpose.
- (d) For safety, Buyer or User should provide protective guards over all shaft extensions and any moving apparatus mounted thereon. The User is responsible for checking all applicable safety codes in his area and providing suitable guards. Failure to do so may result in bodily injury and/or damage to equipment.
- (e) Gearboxes operating in high position should have a protective shield for any possible parts falling down for casual accidents where people are moving under them.
- (f) Hot oil and reducers can cause severe burns. Use extreme care when removing lubrication plugs and vents.
- (g) Make certain that the power supply is disconnected before attempting to service or remove any components. Lock out the power supply and tag it to prevent unexpected application power.
- (h) Reducers are not to be considered fail safe or self-locking devices. If these features are required, a properly sized, independent holding device should be utilized. Reducers should not be used as a brake.
- (i) Any brakes that are used in conjunction with a reducer must be sized or positioned in such a way so as to not subject the reducer to loads beyond the catalog rating.
- (l) Lifting supports including eyebolts are to be used for vertically lifting the gearbox only and not other associated attachments or motors.
- (m) Use of an oil with an EP additive on units with backstops may prevent proper operation of the back-stop. Injury to personnel, damage to the reducer or other equipment may result.
- (n) Overhung loads subject shaft bearings and shafts to stress which may cause premature bearing failure and or shaft breakage from bending fatigue, if not sized properly.

Our company will not be responsible for any direct or indirect damages, caused by a wrong use of the products or for not observing the catalogue/web indication.

1) Definizioni

1.1 Ai fini delle presenti condizioni generali di vendita (di seguito denominate “Condizioni di Vendita”), i seguenti termini avranno il significato di seguito ad essi attribuito:

- “HM”: Hydro-Mec S.p.A.;
- “Cliente”: qualunque società, ente o entità giuridica che acquisti i Prodotti di HM da quest’ultima;
- “Prodotti”: i beni prodotti, assemblati e/o venduti da HM;
- “Ordine/i”: ciascuna proposta di acquisto dei Prodotti inoltrata dal Cliente ad HM esclusivamente tramite e-mail, fax o web;
- “Vendita/e”: ciascun contratto di vendita concluso tra HM e il Cliente a seguito del ricevimento da parte del Cliente dell’accettazione scritta dell’Ordine da parte di HM;

2) Scopi

2.1 Le presenti Condizioni di Vendita si applicano a tutte le Vendite di Prodotti. Nel caso di contrasto tra le condizioni e i termini di cui alle presenti Condizioni di Vendita e le condizioni e i termini pattuiti nella singola Vendita, quest’ultimi prevarranno. HM non sarà vincolata da condizioni generali di acquisto del Cliente (di seguito, “CGA”), neanche nell’ipotesi in cui si faccia loro riferimento o siano contenute negli ordini o in qualsiasi altra documentazione di provenienza del Cliente, senza il preventivo consenso scritto di HM. Le CGA non saranno vincolanti per HM neppure per effetto di tacito consenso.

2.2 HM si riserva il diritto di aggiungere, modificare o eliminare qualsiasi previsione delle presenti Condizioni di Vendita, restando inteso che tali aggiunte, modifiche o cancellazioni si applicheranno a tutte le Vendite concluse a partire dal trentesimo giorno successivo alla notifica al Cliente delle nuove Condizioni di Vendita.

3) Ordini e Vendite

3.1 Il Cliente dovrà inoltrare a HM Ordini specifici contenenti la descrizione dei Prodotti, la quantità richiesta, il prezzo ed i termini richiesti per la consegna.

3.2 La Vendita dovrà ritenersi conclusa: (i) nel momento in cui il Cliente riceva da parte di HM una conferma scritta (tale conferma potrà essere inviata via e-mail, fax o mezzi telematici) conforme ai termini e alle condizioni dell’Ordine (ii) o, nel caso in cui il Cliente riceva da parte di HM una conferma scritta contenente termini difformi da quelli contenuti nell’Ordine, decorsi tre giorni lavorativi dalla data di ricezione della conferma contenente termini difformi senza che nel suddetto periodo pervenga a HM contestazione scritta da parte del Cliente; (iii) o, in assenza di conferma scritta da parte di HM, nel momento in cui i Prodotti saranno consegnati al Cliente.

3.3 Gli Ordini regolarmente accettati da HM non potranno essere annullati dal Cliente senza il consenso scritto di HM.

4) Prezzo dei Prodotti

4.1 I prezzi dei Prodotti saranno quelli indicati nel listino prezzi di HM in vigore al momento dell'inoltro dell'Ordine da parte del Cliente o, qualora il Prodotto non sia inserito nel listino prezzi o il listino prezzi non sia disponibile, quelli indicati nell'Ordine e confermati per iscritto da HM al momento dell'accettazione dell'Ordine. Eccetto quanto diversamente concordato per iscritto tra le parti, i predetti prezzi saranno calcolati franco fabbrica, al netto dell'IVA e degli sconti. Tali prezzi non comprendono i costi di imballaggio, spedizione e trasporto dai locali di HM a quelli del Cliente. Tali costi dovranno essere sostenuti separatamente dal Cliente.

4.2 HM manterrà la proprietà dei Prodotti fino alla completa corresponsione del prezzo degli stessi. Il Cliente dovrà compiere tutti gli adempimenti richiesti dalle leggi locali al fine di rendere valida ed eseguibile nei confronti di tutti i terzi la presente clausola di riserva della proprietà anche operando l'iscrizione in ogni apposito registro, ove localmente richiesto.

5) Termini di consegna

5.1 Eccetto quanto eventualmente diversamente concordato per iscritto tra le parti, HM consegnerà i prodotti franco fabbrica presso i propri stabilimenti, così come questo termine è definito negli INCOTERMS 2010 pubblicati dalla Camera di Commercio internazionale nella loro versione più aggiornata, in vigore al momento della consegna. Se richiesto, HM si occuperà del trasporto dei Prodotti a rischio, costi e spese del Cliente.

5.2 La consegna dovrà avvenire entro il termine indicato nell'Ordine come accettato nella conferma d'ordine. I termini di consegna sono indicativi e non sono termini essenziali ai sensi dell'art. 1457 del Codice Civile e, in ogni caso, non includono i tempi di trasporto.

5.3 Salvo quanto previsto dal precedente art. 5.2, HM non sarà considerata responsabile dei ritardi o della mancata consegna ascrivibili a circostanze che siano fuori dal suo controllo, quali a titolo meramente esemplificativo e senza pretesa di esaustività:

- a) dati tecnici inadeguati o imprecisioni o ritardi del Cliente nella trasmissione a HM di informazioni o dati necessari alla spedizione dei Prodotti;
- b) difficoltà nell'ottenere rifornimenti delle materie prime;
- c) problemi legati alla produzione o alla pianificazione degli ordini;
- d) scioperi parziali o totali, mancanza di energia elettrica, calamità naturali, misure imposte dalle autorità pubbliche, difficoltà nel trasporto, cause di forza maggiore, disordini, attacchi terroristici e tutte le altre cause di forza maggiore;
- e) ritardi da parte dello spedizioniere.

5.4 Il verificarsi di alcuni degli eventi sopra elencati non darà diritto al Cliente di richiedere il risarcimento degli eventuali danni o indennizzi di alcun genere.

6) Trasporto

6.1 Eccetto quanto eventualmente diversamente concordato per iscritto tra le parti, il trasporto avverrà sempre a spese e rischio del Cliente. Nel caso in cui a HM, ai sensi dell'art. 5.1, venga richiesto di occuparsi del trasporto dei Prodotti, HM sceglierà il mezzo di trasporto che riterrà più appropriato in mancanza di specifiche istruzioni del Cliente.

7) Pagamenti

7.1 Salvo diverso accordo scritto tra le parti, HM emetterà le fatture al momento della consegna dei Prodotti.

7.2 Il mancato pagamento nel tempo concordato darà diritto a HM di chiedere al Cliente il pagamento degli interessi scaduti al tasso stabilito dal Decreto Legislativo n. 231/02.

7.3 Il mancato pagamento o il ritardo nei pagamenti superiore a 30 giorni daranno a HM il diritto di sospendere la consegna dei Prodotti e risolvere ogni singola Vendita sottoscritta. La sospensione della consegna dei Prodotti o la risoluzione delle Vendite non darà il diritto al Cliente di pretendere alcun risarcimento dei danni.

7.4 Ogni reclamo relativo ai Prodotti e/o alla consegna dei medesimi non potrà in alcun caso giustificare la sospensione o il ritardo nel pagamento.

8) Non-conformità

8.1 Qualsiasi difformità dei Prodotti consegnati al Cliente rispetto al tipo ed alla quantità indicata nell'Ordine dovrà essere denunciata per iscritto a HM entro cinque giorni dalla data di consegna. Qualora la denuncia non venga comunicata entro il predetto termine, i Prodotti consegnati verranno considerati come conformi a quelli ordinati dal Cliente.

9) Garanzia

9.1 Salvo diverso accordo scritto tra le parti, HM garantisce che i Prodotti sono esenti da vizi/difetti (con esclusione di quelle parti dei Prodotti che non sono prodotte da HM) per un periodo di 12 mesi decorrente dalla data di consegna dei medesimi al Cliente.

9.2 La garanzia non opererà con riferimento a quei Prodotti i cui difetti sono dovuti a

- danni causati durante il trasporto;
- un uso negligente o improprio degli stessi;
- inosservanza delle istruzioni di HM relative al funzionamento, manutenzione ed alla conservazione dei Prodotti;
- riparazioni o modifiche apportate dal Cliente o da soggetti terzi senza la previa autorizzazione scritta di HM.

9.3 A condizione che il reclamo del Cliente sia coperto dalla garanzia e notificato nei termini di cui al presente articolo, HM si impegnerà, a sua discrezione, a sostituire o riparare ciascun Prodotto o le parti di questo che presentino vizi o difetti.

9.4 Il Cliente dovrà denunciare per iscritto a HM, la presenza di vizi o difetti entro 8 giorni dalla consegna dei Prodotti se si tratta di vizi o difetti palesi, oppure, entro 8 giorni dalla scoperta in caso di vizi o difetti occulti o non rilevabili da una persona di media diligenza.

9.5 I Prodotti oggetto di denuncia dovranno essere immediatamente inviati presso la fabbrica di HM, o in qualsiasi altro luogo che quest'ultima indicherà di volta in volta, a costi e spese a carico del Cliente salvo diverso accordo tra le parti, al fine di consentire a HM l'espletamento dei necessari controlli. La garanzia non copre danni e/o difetti dei Prodotti derivanti da anomalie causate da, o connesse a, parti assemblate/aggiunte direttamente dal Cliente o dal consumatore finale. Qualora, nell'ambito della presente garanzia, un Prodotto o un componente difettoso venisse sostituito, la proprietà del Prodotto o del componente sostituito sarà ritrasferita dal Cliente a HM.

9.6 In ogni caso il Cliente non potrà far valere i diritti di garanzia verso HM se il prezzo dei Prodotti non sia stato corrisposto alle condizioni e nei termini pattuiti, anche nel caso in cui la mancata corresponsione del prezzo alle condizioni e nei termini pattuiti si riferisca a Prodotti diversi da quelli per i quali il Cliente intende far valere la garanzia.

9.7 HM non riconosce alcuna garanzia circa la conformità dei Prodotti alle norme e ai regolamenti di Paesi che non rientrano o non appartengono all'Unione Europea. Nessun'altra garanzia, espressa o implicita, quale, a titolo esemplificativo, la garanzia di buon funzionamento o di idoneità per uno scopo specifico, è concessa con riferimento ai Prodotti.

9.8 Senza pregiudizio a quanto indicato nel precedente art. 9.3 e salvo il caso di dolo o colpa grave, HM non sarà responsabile per qualsivoglia danno derivante e/connesso ai vizi dei Prodotti. In ogni caso, HM non sarà ritenuto responsabile per danni indiretti o consequenziali di qualsiasi natura quali, a titolo esemplificativo, le perdite derivanti dall'inattività del Cliente o il mancato guadagno.

10) Diritti di Proprietà Intellettuale

10.1 I Diritti di Proprietà Intellettuale sono di totale ed esclusiva proprietà di HM e la loro comunicazione o utilizzo nell'ambito delle presenti Condizioni di Vendita non crea, in relazione ad essi, alcun diritto o pretesa in capo al Cliente. Il Cliente si obbliga a non compiere alcun atto incompatibile con la titolarità dei Diritti di Proprietà Intellettuale.

11) Clausola risolutiva espressa

11.1 HM avrà facoltà di risolvere, ai sensi e per gli effetti dell'art. 1456 del Codice Civile Italiano, in qualsiasi momento mediante comunicazione scritta da inviare al Cliente, la singola Vendita nel caso di inadempimento delle obbligazioni previste dagli articoli: 4 (Prezzo dei Prodotti); 7 (Pagamenti); 10 (Diritti di Proprietà Intellettuale).

12) Mutamento nelle condizioni patrimoniali del Cliente

12.1 HM avrà diritto a sospendere l'adempimento delle obbligazioni derivanti dalla Vendita dei prodotti, in base all'art. 1461 del Codice Civile Italiano, nel caso in cui le condizioni patrimoniali del Cliente divenissero tali da porre in serio pericolo il conseguimento della controprestazione salvo che sia prestata idonea garanzia.

13) Domicilio legale, legge applicabile e giurisdizione

13.1 HM è legalmente domiciliata presso la sua sede principale.

13.2 Le Condizioni di Vendita e ogni singola Vendita saranno regolate e interpretate in conformità alla Legge Italiana.

13.3 Tutte le controversie derivanti da o connesse alle presenti Condizioni di Vendita e/o ad ogni Vendita saranno soggette alla esclusiva giurisdizione del Tribunale di Vicenza.

13.4 Salvo quanto pattuito nel precedente art. 13.3, HM si riserva il diritto, quando promotore di una azione legale in qualità di attore, di promuovere tale azione nel luogo di residenza del Cliente.

14) ATTENZIONE (Leggere attentamente):

Le seguenti raccomandazioni sono fondamentali per la vostra protezione e per garantirvi molti anni di sicuro funzionamento del vostro prodotto senza alcun problema.

Leggere attentamente tutte le istruzioni prima di azionare il riduttore. L'inappropriata installazione, manutenzione o funzionamento del riduttore può causare incidenti al personale addetto e danni al riduttore stesso.

14.1 E' richiesta autorizzazione scritta per azionare riduttori in ascensori o dispositivi per il movimento delle persone.

14.2 Controllare che alcune applicazioni non eccedano la massima capacità di carico ammessa pubblicata in questo catalogo.

14.3 L'acquirente è l'unico responsabile per la determinazione dell'adeguatezza del prodotto per qualcuna o tutte le utilizzazioni che l'acquirente stesso farà del riduttore. L'applicazione dell'acquirente non potrà essere soggetta ad alcuna implicita garanzia di montaggio per uno scopo particolare.

14.4 Per ragioni di sicurezza l'acquirente dovrà provvedere a porre protezioni adeguate su tutta la lunghezza dell'albero a tutti gli organi in movimento. L'utilizzatore è responsabile del controllo di tutti i codici di sicurezza e la predisposizione di protezioni adeguate. In assenza di tali precauzioni si possono verificare incidenti alle persone e danni agli apparati.

14.5 Su riduttori installati in posizioni elevate utilizzare protezioni adeguate per qualsiasi distacco accidentale di parti nel caso di passaggio di persone al di sotto.

14.6 Olio e riduttori bollenti possono causare gravi ustioni. Usare estrema cautela nella rimozione dei tappi e delle ventole.

14.7 Assicurarsi che la corrente di alimentazione sia scollegata prima di riparare o rimuovere alcun componente. Chiudere l'alimentazione e contrassegnare tale operazione per evitare accensioni accidentali.

14.8 I riduttori non devono essere considerati esenti da guasti o a bloccaggio automatico. Se sono indispensabili queste caratteristiche, deve essere utilizzato un dispositivo indipendente della dimensione adatta. I riduttori non devono essere utilizzati come freni.

14.9 Qualsiasi freno sia utilizzato insieme al riduttore deve essere della giusta grandezza e posizionato in modo da non causare carichi eccessivi non previsti dai dati forniti nel catalogo.

14.10 I dispositivi di sollevamento come le golfare devono essere usati solo per sollevare verticalmente il riduttore e non altri dispositivi associati o motori.

14.11 L'utilizzo di un olio con un additivo EP su gruppi provvisti di dispositivo di arresto possono inficiare l'uso corretto del freno e provocare danni alle persone, alle cose ed al riduttore stesso nonché ad altri apparecchi.

14.12 I Carichi sospesi assoggettano i cuscinetti della vite e la vite stessa a sollecitazioni che possono causare, se non adeguatamente dimensionati, l'usura prematura dei cuscinetti e/o la rottura della vite a causa della resistenza alla flessione.

La nostra ditta non si ritiene responsabile per eventuali danni diretti o indiretti derivanti da un uso improprio dei prodotti e dalla mancata osservanza delle indicazioni riportate a catalogo o web.

HYDRO · MEC

HIGH EFFICIENCY GEARBOXES

Via della Tecnica, 19 - 36050 Sovizzo (VI)
Tel. +39 0444551911 - Fax. +39 0444 536139
hydromec@hydromec.com



GT-GBM-BVX-HM024-ML

